

OUTPUT FLANGE (SAE NO. 510)

<p>DRW81-005 SHEET 1 OF 3 8.1 DTS WITH ZF/HURTH 63IV V-DRIVE TRANSMISSION</p>	<p>UNIT OF MEASURE in. (mm)</p>	<p>SCALE 1" = 1' 25.4 mm = 305 mm</p>
<p>NOTES:          (1) DIMENSIONS REQUIRE A MINIMUM OF 1/2 in. (13 mm) CLEARANCE FOR MOTOR MOUNT DEFLECTION.          (2) SELECT THE APPROPRIATE EXHAUST RISE-HEIGHT TO MAINTAIN A MINIMUM OF 15 in. (381 mm) BETWEEN THE TOP OF THE EXHAUST ELBOW AND THE WATERLINE OF THE BOAT AT MAXIMUM RATED LOAD.          (3) DIMENSIONS APPLY TO POINT OF INTERSECTION OF OUTPUT SHAFT CENTERLINE AND OUTPUT FLANGE FACE.          (4) DIMENSIONS TO SEA WATER PUMP INLET.          (5) BASE OF MOUNT TO BE PARALLEL TO STRINGER. MOUNTS SHOWN AT CENTER OF ADJUSTMENT.</p>		

DRW81-005 SHEET 2 OF 3  
8.1 DTS WITH ZF/HURTH 63IV V-DRIVE TRANSMISSION

UNIT OF MEASURE  
in. (mm)

SCALE  
1" = 1'  
25.4 mm = 305 mm

NOTES:

- (1) DIMENSIONS REQUIRE A MINIMUM OF 1/2 in. (13 mm) CLEARANCE FOR MOTOR MOUNT DEFLECTION.
- (2) SELECT THE APPROPRIATE EXHAUST RISE-HEIGHT TO MAINTAIN A MINIMUM OF 15 in. (381 mm) BETWEEN THE TOP OF THE EXHAUST ELBOW AND THE WATERLINE OF THE BOAT AT MAXIMUM RATED LOAD.
- (3) DIMENSIONS APPLY TO POINT OF INTERSECTION OF OUTPUT SHAFT CENTERLINE AND OUTPUT FLANGE FACE.
- (4) DIMENSIONS TO SEA WATER PUMP INLET.
- (5) BASE OF MOUNT TO BE PARALLEL TO STRINGER. MOUNTS SHOWN AT CENTER OF ADJUSTMENT.

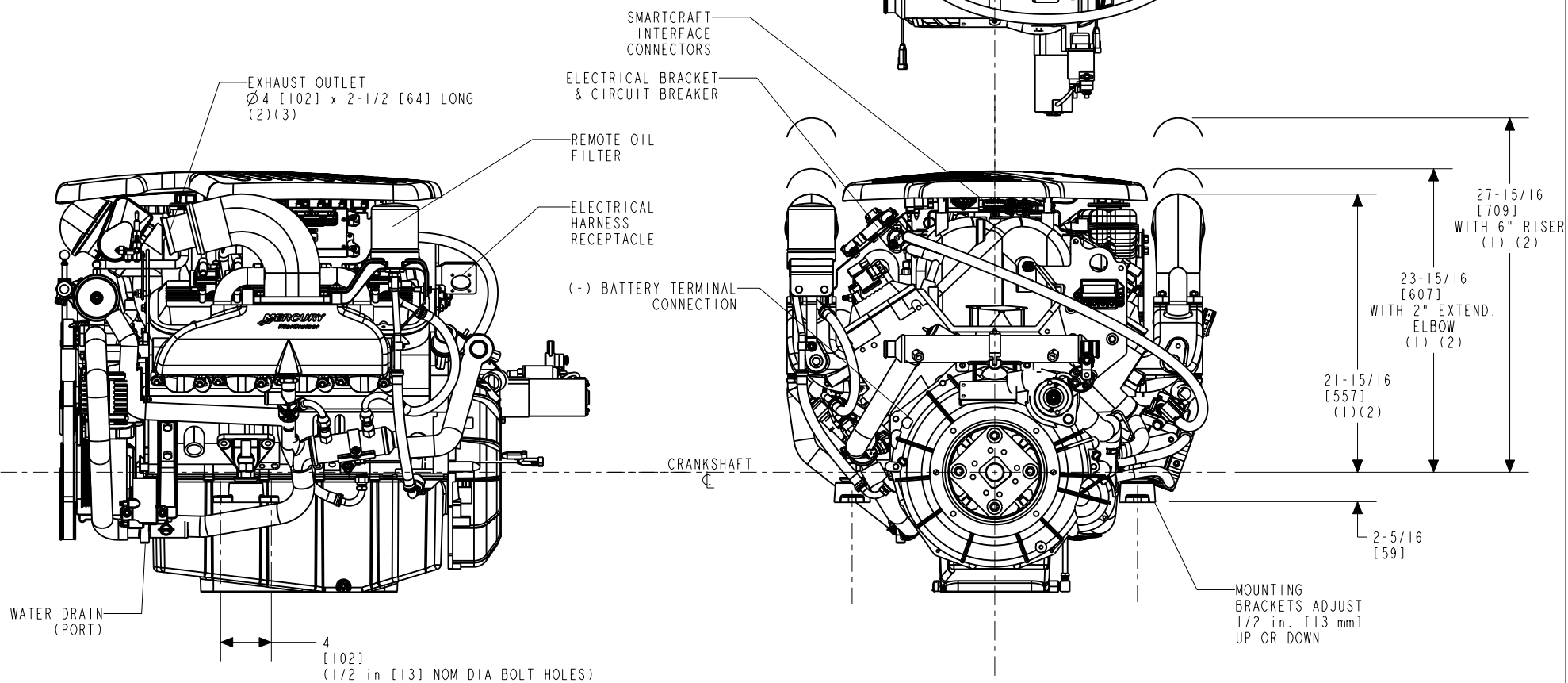
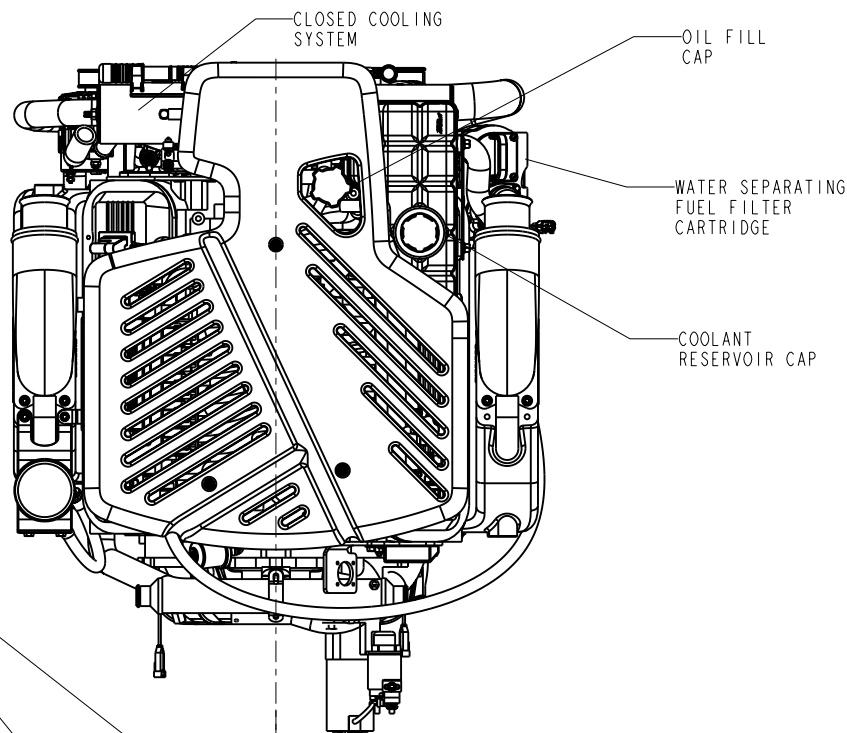

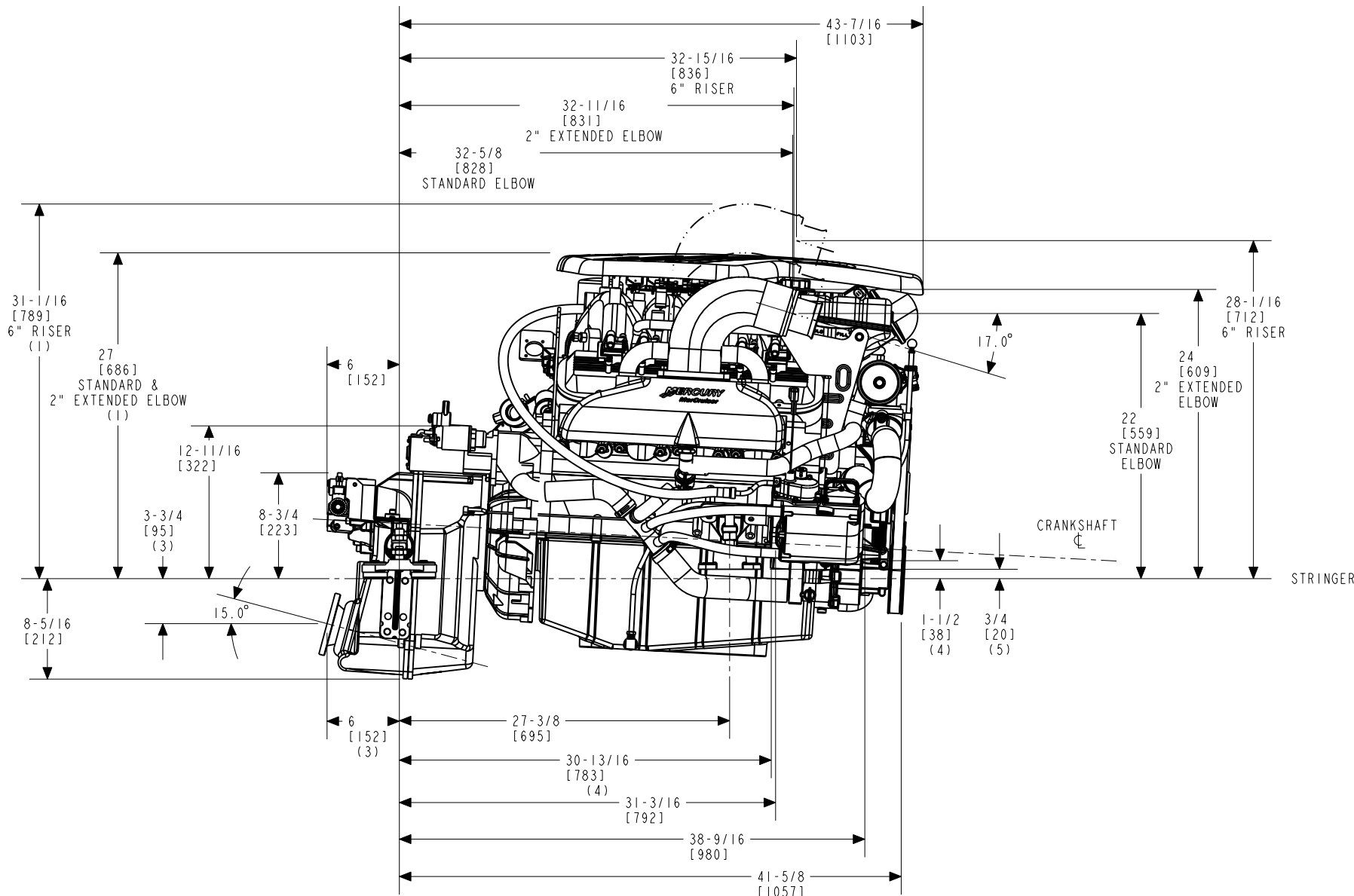

15° PROPSHAFT ANGLE SHOWN

<p>DRW81-005 SHEET 3 OF 3 8.1 DTS WITH ZF/HURTH 63IV V-DRIVE TRANSMISSION</p>	<p>UNIT OF MEASURE in. (mm)</p>	<p>SCALE 1" = 1' 25.4 mm = 305 mm</p>
<p>NOTES:            (1) DIMENSIONS REQUIRE A MINIMUM OF 1/2 in. (13 mm) CLEARANCE FOR MOTOR MOUNT DEFLECTION.            (2) SEE THE INSTALLATION MANUAL FOR EXHAUST SPECIFICATIONS.            (3) DIMENSIONS APPLY TO POINT OF INTERSECTION OF OUTPUT SHAFT CENTERLINE AND OUTPUT FLANGE FACE.            (4) DIMENSIONS TO SEA WATER PUMP INLET.            (5) BASE OF MOUNT TO BE PARALLEL TO STRINGER. MOUNTS SHOWN AT CENTER OF ADJUSTMENT.</p>		