

COMPACT HYDRAULIC STEERING

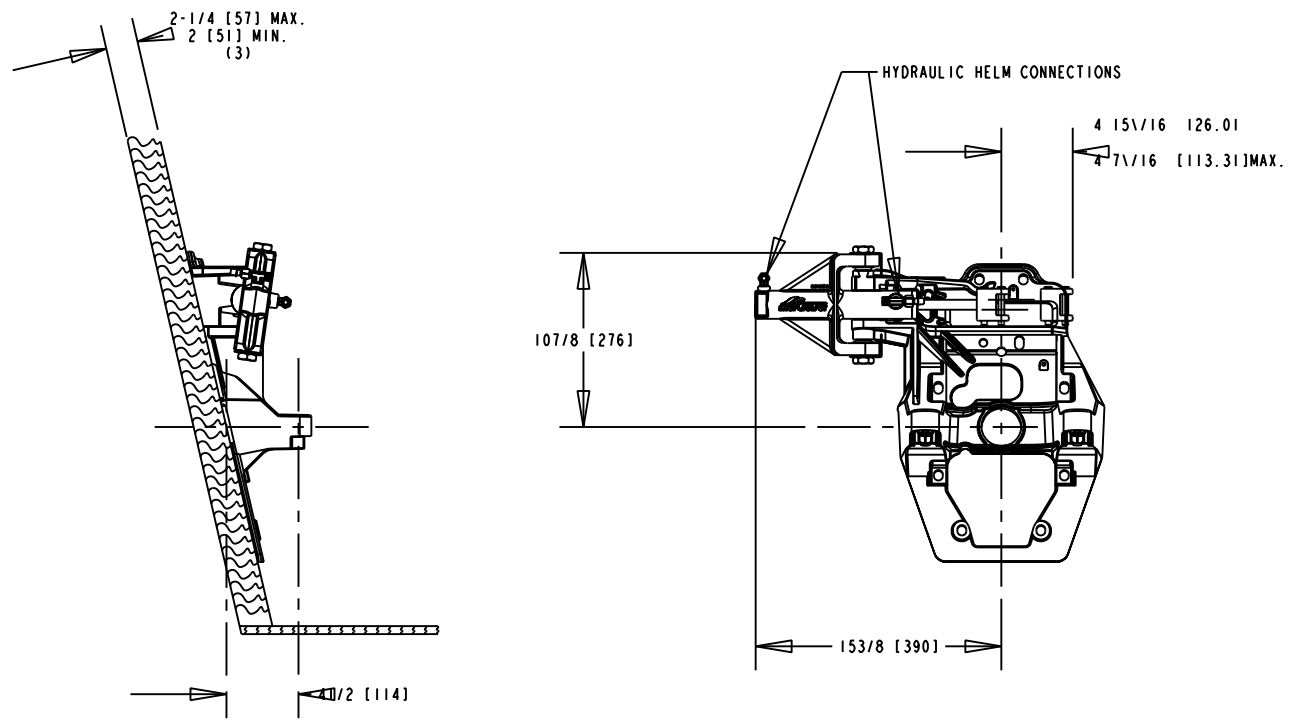

COMPACT HYDRAULIC STEERING

- NOTES:
- (1) DIMENSIONS REQUIRE A MINIMUM 1/2 in. (13mm) CLEARANCE FOR MOTOR MOUNT DEFLECTION.
 - (2) SELECT THE APPROPRIATE EXHAUST RISE-HEIGHT TO MAINTAIN A MINIMUM OF 13 in. (330mm) BETWEEN THE TOP OF THE EXHAUST ELBOW AND THE WATERLINE OF THE BOAT AT MAXIMUM RATED LOAD.
 - (3) INNER AND OUTER SURFACES OF TRANSOM MUST BE PARALLEL WITHIN 1/8 in. (3mm) IN AREA COVERED BY TRANSOM PLATES AND REMAIN WITHIN TRANSOM THICKNESS LIMITS.
 - (4) FOR EXACT LOCATION OF CAVITATION PLATE IN RELATION TO BOAT BOTTOM, REFER TO INSTALLATION INSTRUCTIONS.
 - (5) NUMBERS INSIDE BRACKETS "[]" ARE IN MILLIMETERS.

<p>UNIT OF MEASURE in. (mm)</p>	<p>SCALE APPROX. 1" = 1' 25.4mm = 304mm</p>
-------------------------------------	---