

ITEM NUMBER  
90-864855

ZONE REV		DESCRIPTION	DWN	APP'D
01	REVISED		915	92-21-97

- NOTES:
1. DIMENSIONS REQUIRE A MINIMUM 13mm [1/2] CLEARANCE FOR MOTOR MOUNT DEFLECTION.
  2. FRONT MOUNTS ADJUST 8mm [5/16] UP OR DOWN.
  3. REAR MOUNTS ADJUST 10mm [3/8] UP OR DOWN.
  4. DIMENSIONS APPLY TO POINT OF INTERSECTION OF OUTPUT SHAFT CENTERLINE AND OUTPUT FLANGE FACE.
  5. SECURE SEAWATER HOSE INLET AWAY FORM ALTERNATOR BELT.
  6. BASE OF MOUNT TO BE PARALLEL TO STRINGER. MOUNTS SHOWN AT CENTER OF ADJUSTMENT.
  7. 12° OPTIMUM INCLINED OUTPUT SHAFT ANGLE.
  8. SHOWN WITH ZF63A TRANSMISSION.
  9. NUMBERS INSIDE BRACKETS ARE IN INCHES.

DIMENSION (MM)	OUTPUT SHAFT ANGLE		
	10°~	12°~	15°~
A	147	140	130
B	832	834	836
C	378	366	347
D	110	80	37
E	190	183	185
F	708	711	724
G	1157	1162	1166
H(33° ELBOW)	1202	1201	1196
H(65° ELBOW)	1134	1131	1125
J	1457	1448	1431
K(33° ELBOW)	63	68	74
K(65° ELBOW)	118	120	123
L(33° ELBOW)	338	338	338
L(65° ELBOW)	283	285	289
M	106	111	117

DIMENSION (IN)	OUTPUT SHAFT ANGLE		
	10°~	12°~	15°~
A	5-3/4	5-1/2	5-1/8
B	32-3/4	32-7/8	32-15/16
C	14-7/8	14-3/8	13-5/8
D	4-5/16	3-3/16	1-7/16
E	7-1/2	7-3/16	7-5/16
F	27-7/8	28	28-1/2
G	45-9/16	45-3/4	45-15/16
H(33° ELBOW)	47-1/2	47-3/16	47
H(65° ELBOW)	44-9/16	44-7/16	44-1/4
J	57-3/8	57	56-5/16
K(33° ELBOW)	2-1/2	2-11/16	2-15/16
K(65° ELBOW)	4-5/8	4-3/4	4-13/16
L(33° ELBOW)	13-5/16	13-5/16	13-5/16
L(65° ELBOW)	11-1/8	11-3/16	11-3/8
M	4-3/16	4-3/8	4-5/8

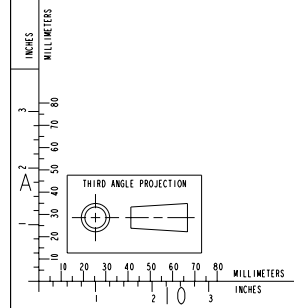
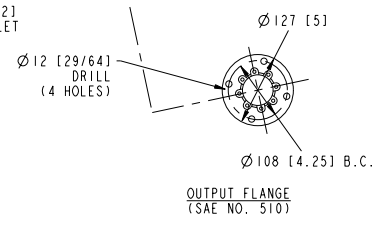
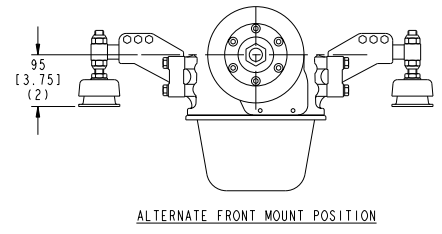
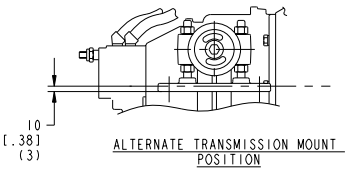
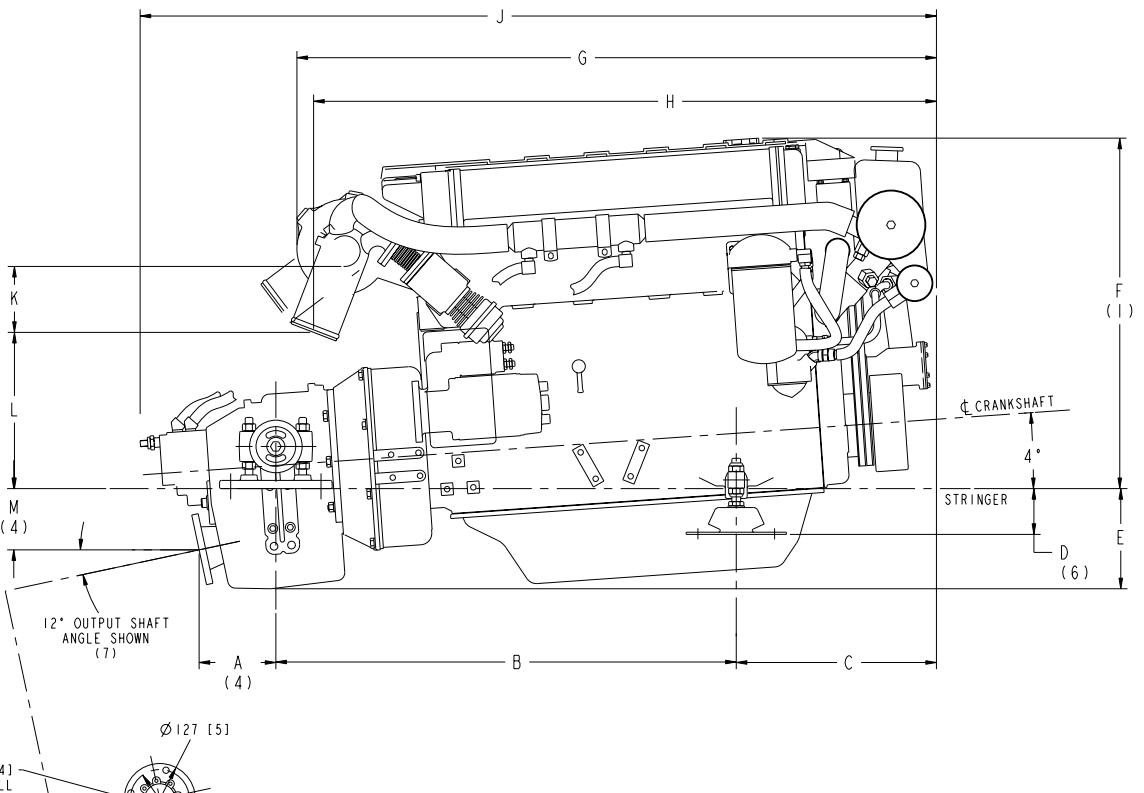
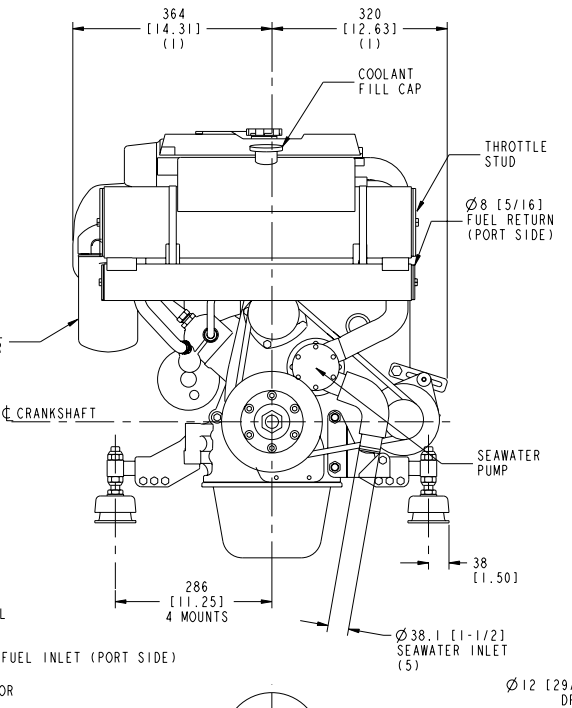
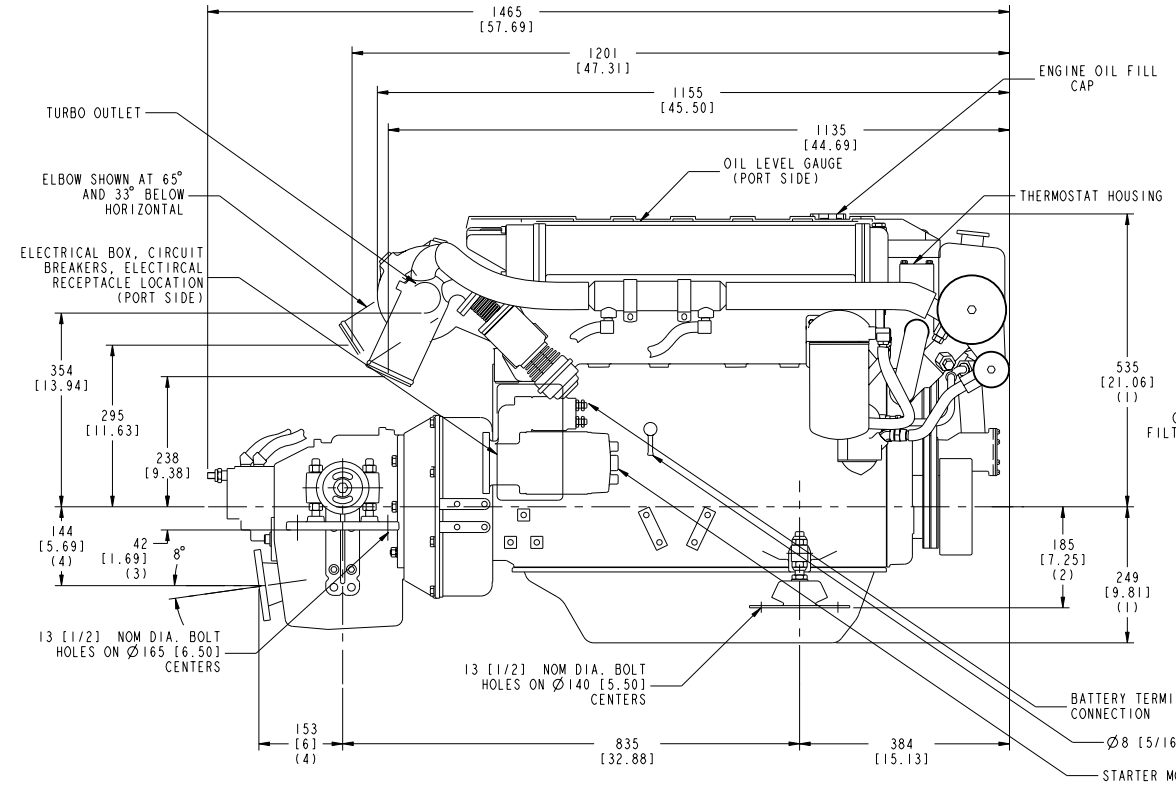

DO NOT SCALE THIS DRAWING  
THIS DRAWING/DATA FILE (AND THE INFORMATION SHOWN THEREON) IS CONFIDENTIAL AND PROPRIETARY AND SHALL NOT BE USED, DISCLOSED TO OTHERS, OR REPRODUCED BY ANY MEANS FOR ANY PURPOSE IN HARD COPY FORM OR IN MACHINE READABLE FILES, WITHOUT WRITTEN CONSENT OF CUMMINS INC., MARKETING CAD SERVICES DEPARTMENT.

PRODUCT GRAPHICS FILE  
NO ORIGINAL DRAWING EXISTS FOR THIS ITEM. THE ENGINEERING GRAPHICS DATA FOR THIS ITEM RESIDES IN THE PRODUCT GRAPHICS FILE AND IS CONTROLLED BY THE AGENCY DESIGNATED AS HAVING ITEM CONTROL.

LAST SECTION LETTER USED: --	REF. DRAWING STANDARDS: ANSI Y14.5M ISO 81101	<b>CUMMINS INC.</b>	
UNLESS OTHERWISE SPECIFIED DIMENSIONS ARE IN: MM (1) ARE IN: IN	ITEM NAME: 4.2 E1 (250,270,320)w/ ZF63A	IDENTIFIER: INSTALLATION DIAGRAM	
DWN: D. SOMIN	APPD: UNCHECKED	SCALE: N/A	ITEM CONTROL: MCS
APPD: --	ITEM NUMBER: 90-864855	SHEET 1 OF 1	