

OPTIONAL INTERMEDIATE EXHAUST ELBOW

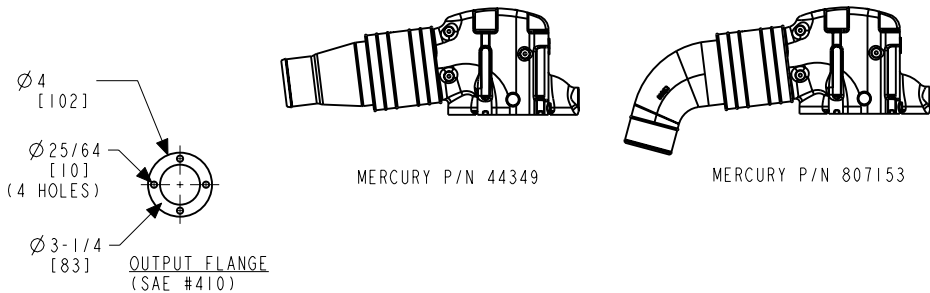

90-864751-004 SHEET 1 OF 2
 350 MAG MPI, TOW SPORTS
 WITH VELVET DRIVE 71C WALTER V-DRIVE

UNIT OF MEASURE
 in. (mm)

SCALE
 1" = 1'
 25.4 mm = 305 mm

NOTES:

- (1) DIMENSIONS REQUIRE A MINIMUM OF 1/2 in. (13 mm) CLEARANCE FOR MOTOR MOUNT DEFLECTION.
- (2) SELECT THE APPROPRIATE EXHAUST RISE-HEIGHT TO MAINTAIN A MINIMUM OF 1 in. (381 mm) BETWEEN THE TOP OF THE EXHAUST ELBOW AND THE WATERLINE OF THE BOAT AT MAXIMUM RATED LOAD.
- (3) DIMENSIONS APPLY TO POINT OF INTERSECTION OF OUTPUT SHAFT CENTERLINE AND OUTPUT FLANGE FACE.
- (4) DIMENSIONS TO SEA WATER PUMP INLET.
- (5) BASE OF MOUNT TO BE PARALLEL TO STRINGER. MOUNTS SHOWN AT CENTER OF ADJUSTMENT.

NOTES:

- (1) DIMENSIONS REQUIRE A MINIMUM OF 1/2 in. (13 mm) CLEARANCE FOR MOTOR MOUNT DEFLECTION.
- (2) SELECT THE APPROPRIATE EXHAUST RISE-HEIGHT TO MAINTAIN A MINIMUM OF 1 in. (381 mm) BETWEEN THE TOP OF THE EXHAUST ELBOW AND THE WATERLINE OF THE BOAT AT MAXIMUM RATED LOAD.
- (3) DIMENSIONS APPLY TO POINT OF INTERSECTION OF OUTPUT SHAFT CENTERLINE AND OUTPUT FLANGE FACE.
- (4) DIMENSIONS TO SEA WATER PUMP INLET.
- (5) BASE OF MOUNT TO BE PARALLEL TO STRINGER. MOUNTS SHOWN AT CENTER OF ADJUSTMENT.

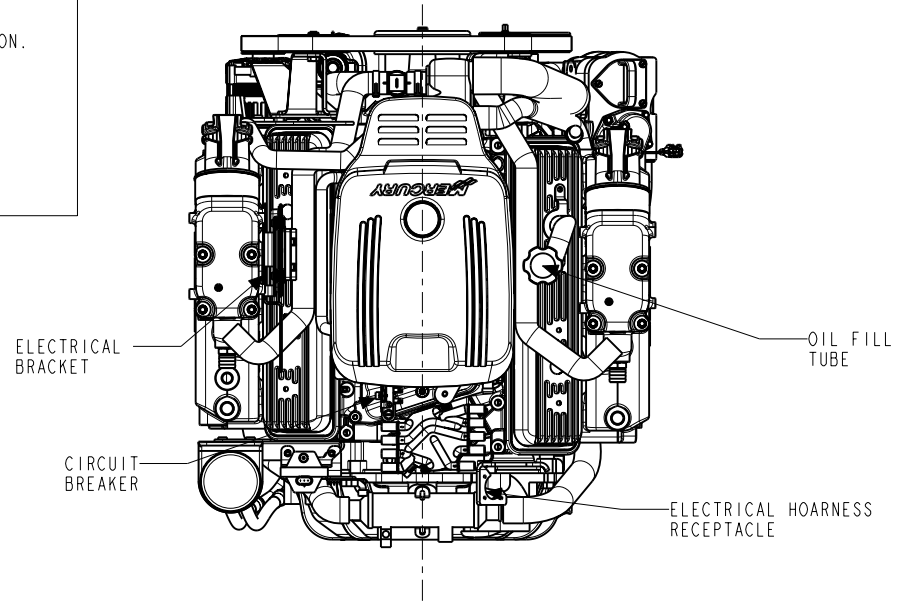

EXHAUST OUTLET
 \varnothing 4" [102] X
 2" [51] LONG

