

	150	135
<b>Commercial Rating</b>	Medium Duty	Medium Duty
<b>Emission Cert.</b>	not required	not required
<b>Configuration / Cycle</b>	I6, 4 stroke diesel	I6, 4 stroke diesel
<b>Dry Weight (k g)</b>	530	530
<b>Direction of Rotation</b>	CCW	CCW
<b>Valves per Cylinder</b>	2	2
<b>Displacement (L)</b>	6.7L	6.7L
<b>Bore x Stroke (mm)</b>	104 x 132	104 x 132
<b>Air Handling</b>	Naturally Aspirated	Naturally Aspirated
<b>Rated RPM</b>	2,800	2,800
<b>Output (mHP / kW)</b>	150 / 110	135 / 99
<b>Max Torque (N-m)</b>	418 at 2,000	385 at 2,300
<b>Engine Cooling</b>	closed cooled	closed cooled
<b>Engine Stop</b>	fuel shut off	fuel shut off
<b>Flywheel Housing</b>	SAE 3	SAE 3
<b>Bobtail length (mm)</b>	1,085	1,072
<b>Bobtail width (mm)</b>	706	706
<b>Bobtail height (mm)</b>	877	877
<b>Inboard: ZF 220</b>	1.00:1, 1.50:1, 1.96:1, 2.48:1 and 3.00:1	not applicable
<b>Inboard: ZF 220A</b>	1.24:1, 1.53:1, 2.04:1, and 3.00:1	not applicable
<b>Inboard: ZF 280IV</b>	1.56:1, 2.06:1, and 2.56:1	not applicable
<b>Inboard: ZF 280-1</b>	not applicable	not applicable
<b>Inboard: ZF 280-1A</b>	not applicable	not applicable
<b>Inboard: ZF 45A</b>	1.26:1, 1.51:1, 2.03:1, and 2.43:1	1.26:1, 1.51:1, 2.03:1, and 2.43:1
<b>Sterndrive – Primary***</b>	Bravo 2X 1.65:1	Bravo 2X 1.81:1
<b>Sterndrive – Optional***</b>	Bravo 2X 1.81:1	Bravo 2X 1.65:1

\*\*\* The commercial rating for all sterndrive hardware is Light Duty Cycle, LDC

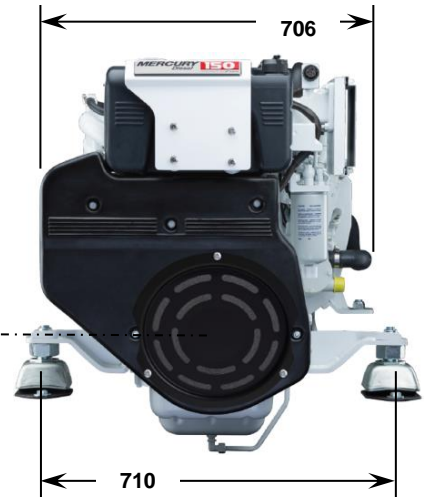
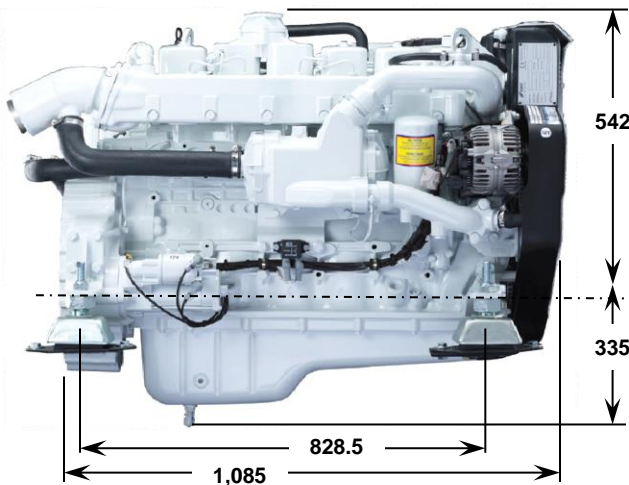
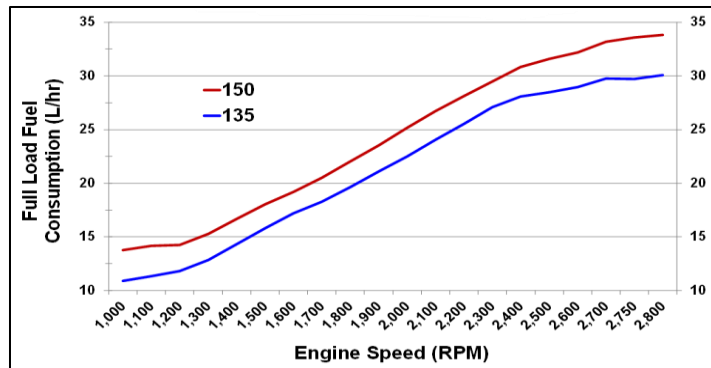
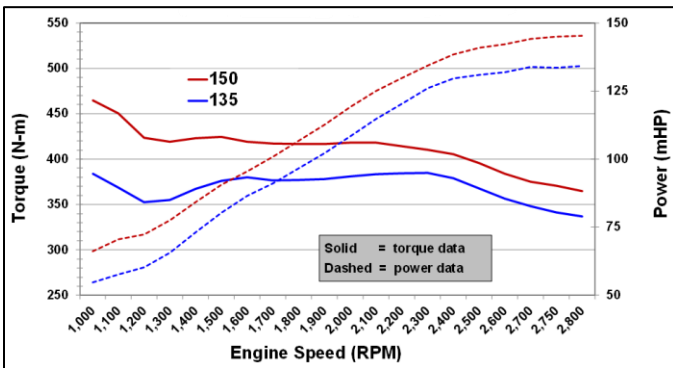

Crankshaft Centerline