



**MERCURY**<sup>®</sup>





---

## General Information

---

Basic Operation and Features.....	1
Automatic Engine Detection Feature.....	3
Alarm Warnings with Descriptive Text.....	4
Identifying and Using the Screen Categories.....	9

---

## Settings

---

Using the Light and Contrast Menu Options .....	10
Setting the Units.....	16
Available Screens.....	18
Turning the Screens On.....	19
Setting the Trim.....	34
Setting the Tanks.....	38
Setting the Alarms.....	46
Setting the External Sensors.....	50
Setting the Offsets.....	57
Setting the Clock.....	63
Economy (ECO) Settings.....	67
Setting the System.....	72
Reset Gauge to the Factory Default Settings.....	74
Help Menu.....	77

---

## Propulsion Menu

---

Using Propulsion Screens .....	80
Available Propulsion Screens .....	80
Troll Control Screen.....	83
Water Screen.....	86
Oil Screen.....	86
Peak Speed Screen.....	87
Fuel Pressure Screen.....	88
RPM Synchronize Screen.....	88
Engine Location Fuel Use .....	89
Volts/Hours Screen.....	90
Boost Pressure Screen.....	90
Trim Synchronize Screen.....	91
Trim Screen.....	91
Trim/Tab Screen.....	92

---

## Vessel Menu

---

Using the Vessel Screens.....	93
Available Vessel Screens.....	93
Economy (ECO) Screen.....	97
Trip Data Screen.....	102
Range Screen.....	105
Trim Screen.....	106
Tanks.....	107
Tabs Screen.....	108
GPS Screen.....	108
To Waypoint Screen.....	109
Steering Screen.....	109
Depth Screen.....	110

---

## Full Screens

---

Full Screens Features and Options .....	111
Maintenance Screen.....	116

---

## Favorite Screens

---

Favorites Screen Features and Options.....	119
--	-----

---

## Alarms

---

Alarms Screen.....	123
--------------------	-----

---

## Owners Assistance

---

Service Assistance.....	130
-------------------------	-----

---

# GENERAL INFORMATION

## Basic Operation and Features

**IMPORTANT:** MercMonitor can be assimilated into many different power package configurations; from a single engine low horsepower outboard motor, to a multiengine multistation digital throttle and shift vessel. There may be some gauge features, displays, operations, and warnings that will not be applicable for your power package. Some screens can be turned on, but will not show any changes to the display. See your selling dealer for an explanation of what information your power package can display.

**Power up:** After the ignition is turned on, the front splash screen will display the name of the gauge, the level of the gauge, and the version of the software for approximately two seconds.

**Lights:** Adjusts the brightness and contrast of the gauge.

**Buttons:** The "MODE" button is used for selecting information screens. The "+" and "-" buttons are used for setting engine speed for cruise control, launch control, and setting gauge calibrations. To return to the previous screen, hold the "MODE" button down for three to five seconds.

**Cruise control:** Sets and controls the speed of the engine for cruising.

**Launch control:** Controls the speed of acceleration from idle to cruise speed.

**Engine Guardian System:** Monitors the critical sensors on the engine for any early indication of problems. The system will respond to a problem by reducing engine speed and alerting the operator to a potentially damaging situation.

**Warning system:** The system sounds the warning horn and displays the warning "AL" in the right corner of the "Main Menu" screen. The alarm screen will pop up, flashing a warning icon in the middle of the screen and the "AL" in the upper right side of the screen. Press the "+" button to display the descriptive text.

**IMPORTANT:** Optional sensors such as depth, fuel, paddle wheel, and steering angle, should always be connected to the starboard engine when using SmartCraft gauges version 4.0 or later.

# GENERAL INFORMATION

## SYSTEM CHECK

- The system check screen will appear after the front splash screen. This option must be enabled to view it. Depending on the installed power package, the system check screen will display the overall condition of the battery and a few other sensor conditions that are important for that power package. The component description will be displayed on the left side of the monitor, its corresponding icon will be off-center right, an icon in motion to the right will indicate what is being checked. When the component checks good, the icon in motion will change to "OK." If the system check identifies a problem, the icon in motion will change to a warning icon. You can bypass the system check by pressing the "MODE" button to skip the check.

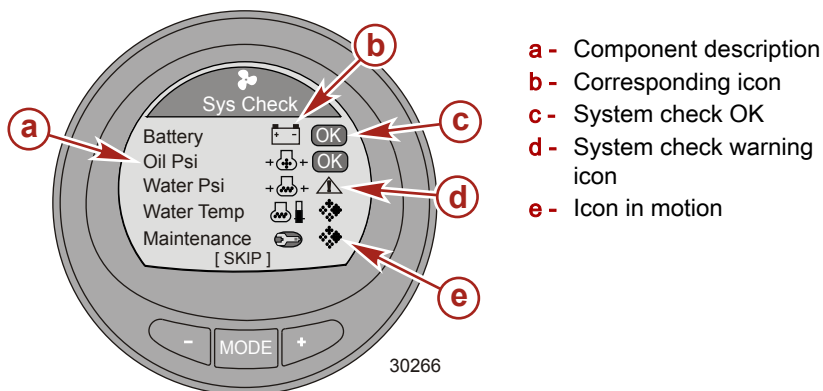

- After the system check is completed and no problem is identified, the monitor screen reverts to the last screen that was visible before the key switch was turned off. If a problem was identified, the alarm screen will be displayed. Refer to **Alarm Warnings with Descriptive Text**.

# GENERAL INFORMATION

## PRODUCTS WITH EMISSIONS CONTROL

After the ignition is turned on, the front splash screen will display the name of the gauge, the level of the gauge, and the version of the software for approximately two seconds. In the upper left-hand corner of the display, a small engine icon will also be visible. The icon is a representation the power package has emissions control onboard diagnostics, also known as OBD. The icon will only be seen during the key up process unless a system fault is detected. When an OBD fault is detected, the OBD icon will be displayed in the upper left-hand corner on all system screens.

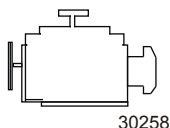

**OBD icon**

## Automatic Engine Detection Feature

The SmartCraft monitor has an automatic engine detection feature. This feature automatically detects which engine type is used and configures the gauge to match that engine type.

The first power up of the gauge, or after a factory reset, the gauge will display "AUTODETECT." Press the "MODE" button to start the automatic engine detection feature and the gauge will determine the engine type. This will preset the data monitoring screens to make the initial setup easier.

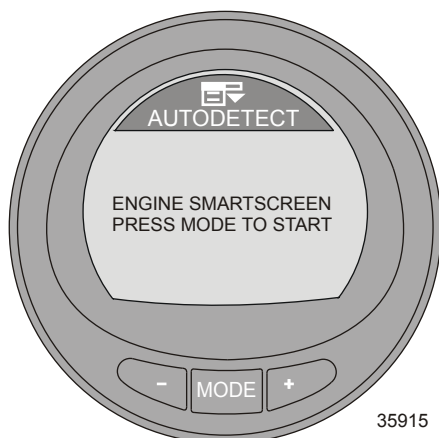

If the gauge shows a warning of "NO STARBOARD ENGINE" or "MULTIPLE STARBOARD ENGINES," the engine location (port and starboard) must be selected by an authorized dealer.

# GENERAL INFORMATION

## Alarm Warnings with Descriptive Text

**NOTE:** Descriptive text alarm warning screens may not be available on some engine models.

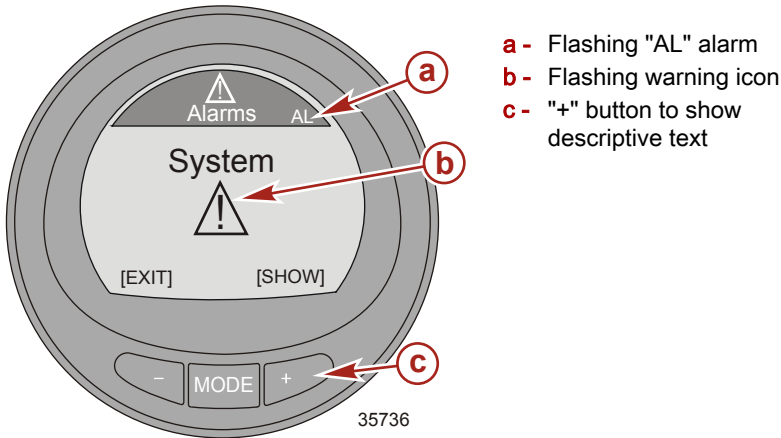

- a** - Flashing "AL" alarm
- b** - Flashing warning icon
- c** - "+" button to show descriptive text

When a problem is detected, the "AL" alarm appears and a pop-up window with the alarm location and fault number will be displayed. The faulty component or warning is described in the text. Press the "+" button for more information. This screen gives a detailed description of the fault text. Press the "+" button to view the required corrective action.

The alarm message will stay displayed until the "-" button is pressed. This action will exit the warning screen. If there are multiple alarms, press the "MODE" button to view the next warning display.

If a problem can cause immediate engine damage, the Engine Guardian System will respond to the problem by limiting engine power. Immediately reduce the throttle speed to idle and refer to the warning messages. If the "MODE" button is pressed to display a different screen, the flashing alarm signal "AL" will appear in the upper right corner to indicate there still is a problem. Refer to the appropriate service manual for further explanation of the problem and the correct action to take.



# GENERAL INFORMATION

## VIEWING DESCRIPTIVE TEXT

1. When a problem is detected, the "AL" alarm will flash on the display and a pop-up window displays the system where the fault is located, the fault code, and what component is identified as a problem.

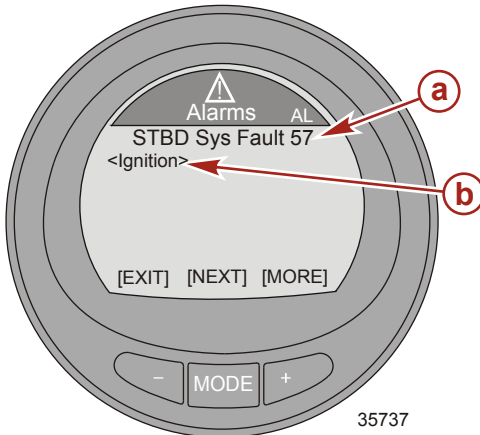

- a - System fault and code
- b - Component

2. Press the "+" button to view the descriptive warning text. The identified component expands to show additional text describing the fault.

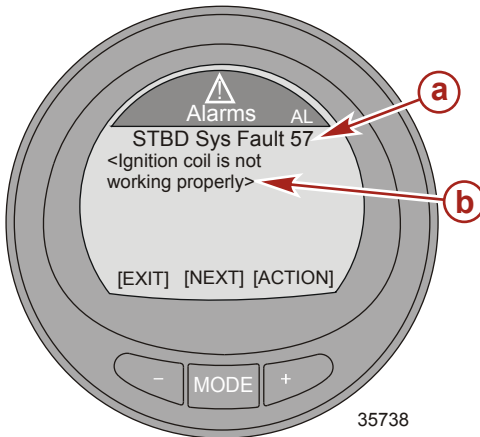

- a - System fault and code
- b - Additional text describing the fault

# GENERAL INFORMATION

3. Press the "+" button to view the descriptive recommended actions to proceed with.

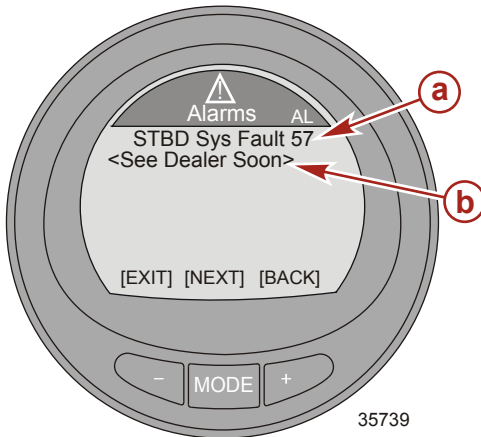

- a - System fault and code
- b - Recommended action

4. Press the "+" button to go back to the component identification or press the "MODE" button to view the next descriptive warning text.
5. Press the "-" button to exit the alarm screen.

## EMISSION CONTROL ALARM WARNINGS WITH DESCRIPTIVE TEXT

When a problem is detected with the emission control system, a pop-up window with the "AL" flashing in the upper right-hand corner, an engine icon in the upper left-hand corner, "OBD Service Soon" and a large engine icon will be displayed on the screen. The screen will flash between two alarm displays. Pressing the "-" button while this screen is displayed will exit to the last screen that was on the monitor.

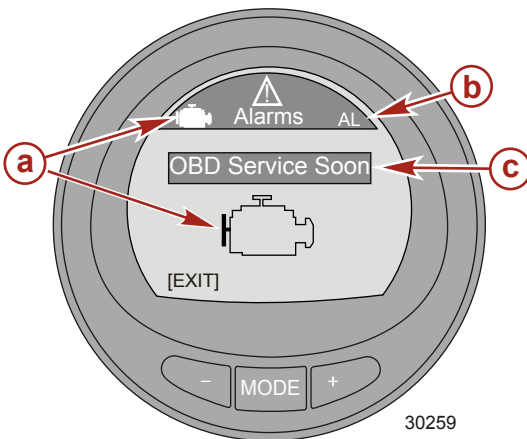

- a - Engine icon
- b - Flashing "AL"
- c - OBD Service Soon

# GENERAL INFORMATION

1. The second flashing alarm display shows the engine OBD icon, the flashing "AL," and warning icon. Press the "+" button for more information.

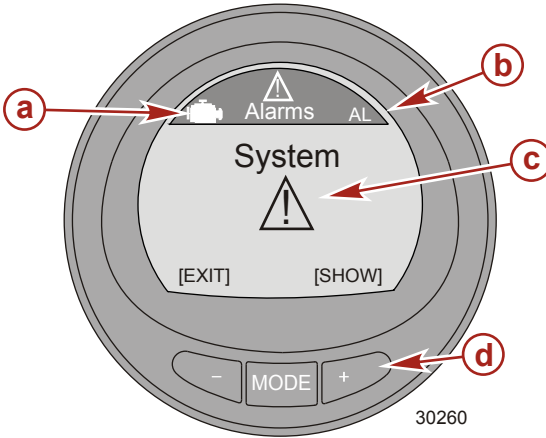

- a** - OBD icon
- b** - Flashing "AL" alarm
- c** - Flashing warning icon
- d** - "+" button to show descriptive text

# GENERAL INFORMATION

- The screen displays the engine location, the system fault code number, and a description of the faulty component. Press the "+" button for more information.

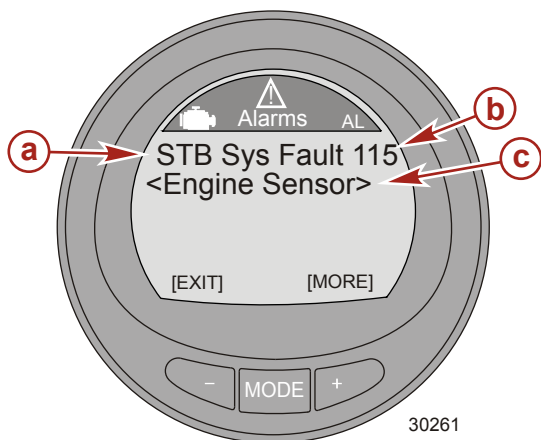

- a** - Engine location
- b** - Fault code
- c** - Fault description

- A detailed description of the fault component is explained. Press the "+" button for information on a corrective action.

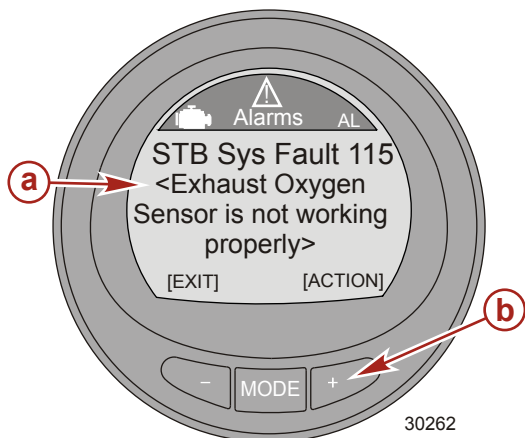

- a** - Detailed description of the fault component
- b** - "+" button to show corrective action

# GENERAL INFORMATION

## Identifying and Using the Screen Categories

The monitor displays engine and vessel information through various screens. These screens can be selected to be favorites which will flash on the screen for a specific amount of time. The "Settings" menu option allows the screens to be turned off or on. The "Settings" menu option also allows the calibration of the monitor to the various different sensors like the fuel, trim, tabs, and steering to name a few.

- **"Propulsion"** contains all screens related to the propulsion system; trim, engine performance, troll control.
- **"Vessel"** contains screens related to fuel use, tank levels, tabs, GPS data, steering position, and other items.
- **"Full Screens"** displays various information from the propulsion and vessel menu in large, easy to read letters.
- **"Favorites"** are specific screens selected by the operator to be reviewed quickly. The favorites will remain on the screen for a specific amount of time. This time can be one second up to 30 seconds or turned "OFF" to advance manually through the screens. A total of nine screens can be selected from the "Propulsion" menu, "Vessel" menu, or "Full Screens" menu. Press and hold the "-" and "+" buttons down at the same time for three to five seconds to add the screen to the favorites menu.
- **"Alarms"** displays information on the location, identifies, and advises a corrective action to take for all warning alarms. While in the "Alarms" category, press the "+" button for more detailed descriptive text about the fault. Press the "+" button again to review the recommended corrective action to take. Press the "MODE" button to review the next fault, or press the "-" button to exit the "Alarms" descriptive text screen.
- **"Settings"** allows the user to turn on and off screens, select a type of measurement (knots, kilometers, miles), select a screen color, adjust the contrast and brightness of the screen, select a digital or analog clock display, adjust and correct various different sensor parameters (tanks, trim, tabs), activate a GPS interface with the gauge, give the gauge a specific name (up to 14 characters), and reset the gauge to the factory default settings.

# SETTINGS

## Using the Light and Contrast Menu Options

1. While in the "Main Menu," press the "-" or "+" button to highlight the "Settings" menu.
2. Press the "MODE" button to edit the "Light/Contrast" menu.

### CONTRAST

1. Press the "MODE" button to edit the "Contrast" option.
2. Press the "-" or "+" button to edit the contrast level of the monitor screen.

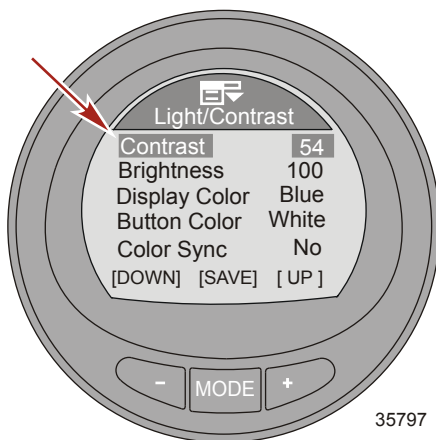

3. Press the "MODE" button to save the contrast setting.
4. To exit the "Light/Contrast" menu, press the "-" or "+" button to highlight the "Exit" option. Press the "MODE" button to exit the "Light/Contrast" menu.

### BRIGHTNESS

1. Press the "-" button to highlight the "Brightness" option.
2. Press the "MODE" button to edit the brightness of the monitor screen.

# SETTINGS

3. Press the "-" or "+" button to change the brightness of the monitor screen.

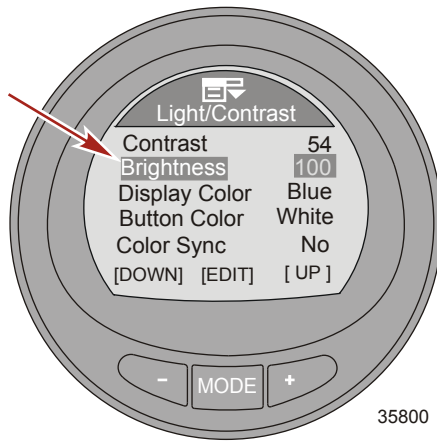

4. Press the "MODE" button to save the brightness setting.
5. To exit the "Light/Contrast" menu, press the "-" or "+" button to highlight the "Exit" option. Press the "MODE" button to exit the "Light/Contrast" menu.

## DISPLAY COLOR

The display backlighting color can be changed to red, blue, green, white, yellow, purple, and ice blue. All the monitor colors can be selected to be displayed for approximately 15 seconds each. After the 15 seconds, the color will fade and change into the next color. This is referred to as the color "Wave."

1. Press the "-" button to highlight the "Display Color" option.
2. Press the "MODE" button to edit the display color of the monitor screen.

# SETTINGS

3. Press the "-" or "+" button to select a color, or select "Wave" for the color of the monitor screen.

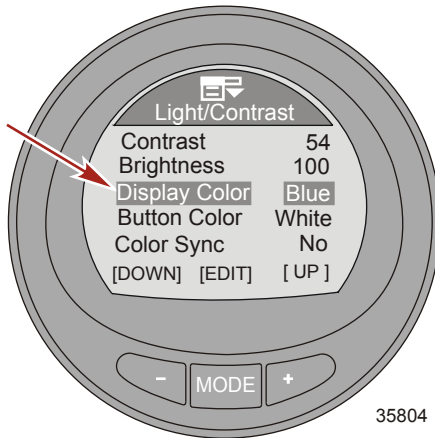

4. Press the "MODE" button to save the display color setting.
5. To exit the "Light/Contrast" menu, press the "-" or "+" button to highlight the "Exit" option. Press the "MODE" button to exit the "Light/Contrast" menu.

## BUTTON COLOR

The "-", "+," and "MODE" button light color can be changed to red, blue, green, white, yellow, purple, and ice blue. All of the button colors can be selected to be displayed for approximately 15 seconds each. After the 15 seconds, the color will fade and change into the next color. This is referred to as the color "Wave."

1. Press the "-" button to highlight the "Button Color" option.
2. Press the "MODE" button to edit the button colors.



# SETTINGS

3. Press the "-" or "+" button to select a color, or select "Wave" for the color of the buttons.

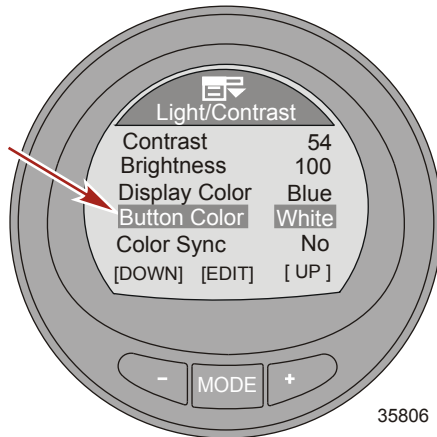

4. Press the "MODE" button to save the button color setting.
5. To exit the "Light/Contrast" menu, press the "-" or "+" button to highlight the "Exit" option. Press the "MODE" button to exit the "Light/Contrast" menu.

## COLOR SYNC

The "Color Sync" feature selects the same color for the backlight and the buttons. Turning the color synchronize on ("Yes"), turns the "Button Color" control feature off.

1. Press the "-" button to highlight the "Color Sync" option.

# SETTINGS

2. Press the "MODE" button to turn the option on ("Yes"), or turn the option off ("No").

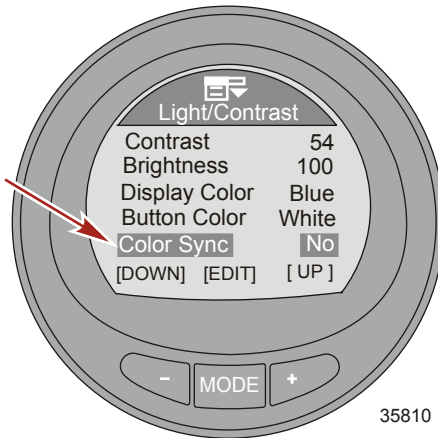

3. To exit the "Light/Contrast" menu, press the "-" or "+" button to highlight the "Exit" option. Press the "MODE" button to exit the "Light/Contrast" menu.

## REMOTE LIGHT

The "Remote Light" feature allows control of all the monitor gauge lighting from any monitor gauge. This feature controls the brightness, display color, button color, and night time mode. Two or more monitor gauges must have this feature turned on for the remote light feature to function.

1. Press the "-" button to highlight the "Remote Light" option.
2. Press the "MODE" button to turn the option on ("Yes"), or turn the option off ("No").

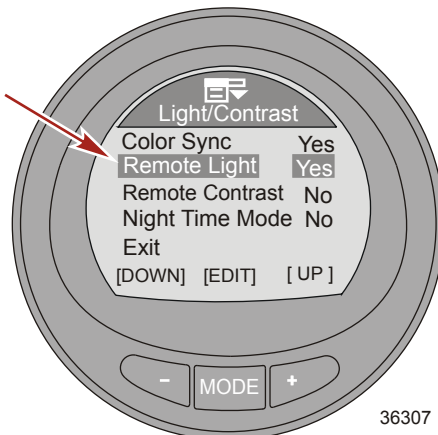

# SETTINGS

3. To exit the "Light/Contrast" menu, press the "-" or "+" button to highlight the "Exit" option. Press the "MODE" button to exit the "Light/Contrast" menu.

## REMOTE CONTRAST

The "Remote Contrast" feature allows control of the monitor gauge contrast from any monitor gauge. This feature controls only the contrast. Two or more monitor gauges must have this feature turned on for the remote contrast feature to function.

1. Press the "-" button to highlight the "Remote Contrast" option.
2. Press the "MODE" button to turn the option on ("Yes"), or turn the option off ("No").

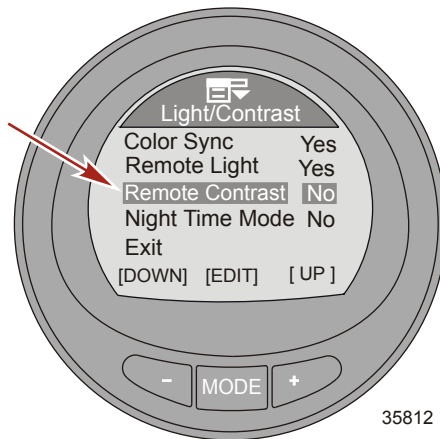

3. To exit the "Light/Contrast" menu, press the "-" or "+" button to highlight the "Exit" option. Press the "MODE" button to exit the "Light/Contrast" menu.

## NIGHT TIME MODE

"Night Time Mode" darkens the monitor screen, turning the letters and numbers to the color selected. This mode when turned on, significantly decreases the amount of backlighting on the gauge.

1. Press the "-" button to highlight the "Night Time Mode" option.

# SETTINGS

2. Press the "MODE" button to turn the option on ("Yes"), or turn the option off ("No"). A third option automatically ("AUTO") selects the "Night Time Mode" when the ambient light conditions fade.

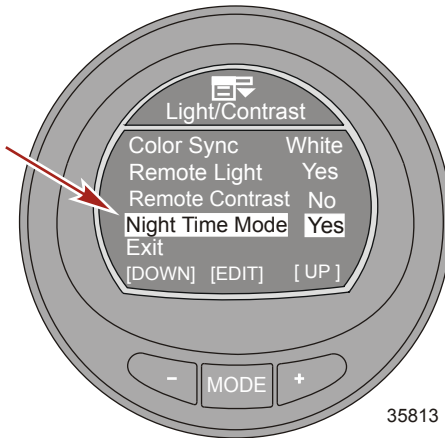

3. To exit the "Light/Contrast" menu, press the "-" or "+" button to highlight the "Exit" option. Press the "MODE" button to exit the "Light/Contrast" menu.

## Setting the Units

The "Units" menu option changes the display units of measurement to English ("Eng") or metric ("Met"), and the speed display to miles per hour ("MPH"), kilometers per hour ("KMH"), or knots ("KN").

1. While in the "Main Menu," press the "-" or "+" button to highlight the "Settings" menu.

# SETTINGS

2. Press the "MODE" button to enter the "Settings" menu.

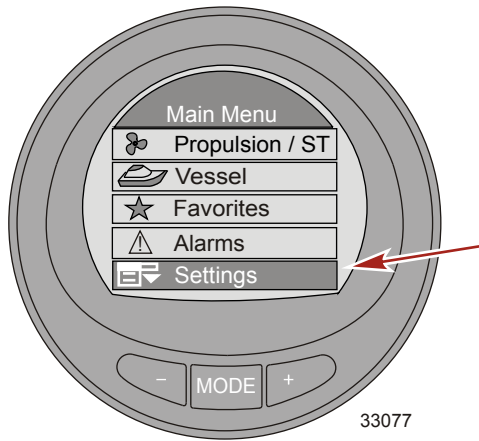

3. Press the "-" button to highlight the "Units" menu.
4. Press the "MODE" button to edit the "Units" menu.

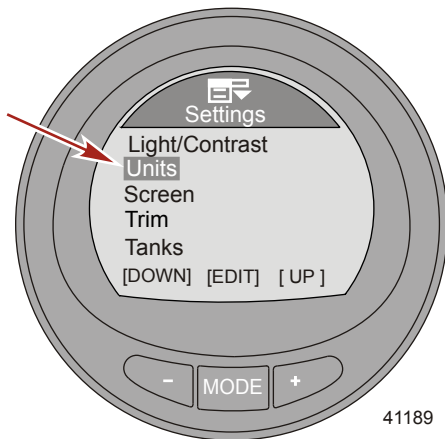

# SETTINGS

5. Press the "MODE" button to change the display units to English ("Eng"), or metric ("Met").

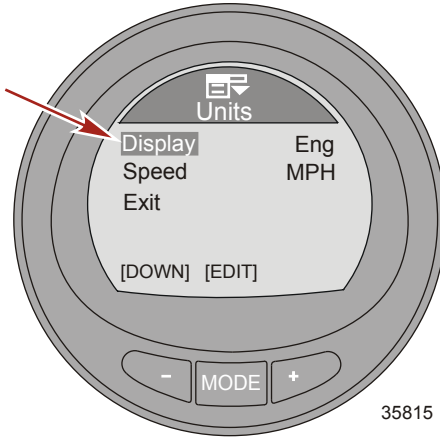

6. Press the "-" button to highlight the "Speed" unit.
7. Press the "MODE" button to change the speed units to miles per hour ("MPH"), kilometers per hour ("KMH"), or knots ("KN").

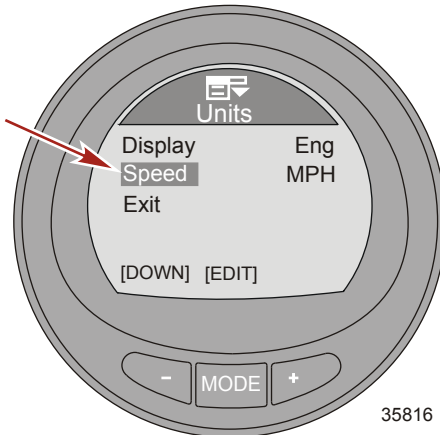

8. Press the "-" button to highlight the "Exit" option. Press the "MODE" button to exit the "Units" menu.

## Available Screens

Within the "Screens" menu, screens can be turned off or on. The "Full Screens" submenu has several full screens that can be turned off or on. Screens that are turned off or on also have a direct relation to the various screens in the propulsion and vessel menus, and are dependant on the power package installed that supports the different sensors.

# SETTINGS

- Full Screens
  - Speed
  - Depth
  - Air Temperature
  - Coolant
  - Clock
    - Analog
    - Digital
  - Oil Temperature
  - Fuel Pressure
  - Oil Pressure
  - Water Pressure
  - Maintenance
- ECO Screen
- System Check
- Trim/RPM
- Peak Speed
- Water Information
- Oil Information
- Fuel Pressure
- Volts/Hours
- Fuel Used
- Depth
- Steering Position
- Boost Pressure
- Tabs
- GPS Data
- Waypoint
- Troll Control
- Screen Synchronize
- Favorite Slide

## Turning the Screens On

### FULL SCREENS OPTIONS

1. While in the "Main Menu," press the "-" or "+" button to highlight the "Settings" menu.
2. Press the "MODE" button to enter the "Settings" menu.

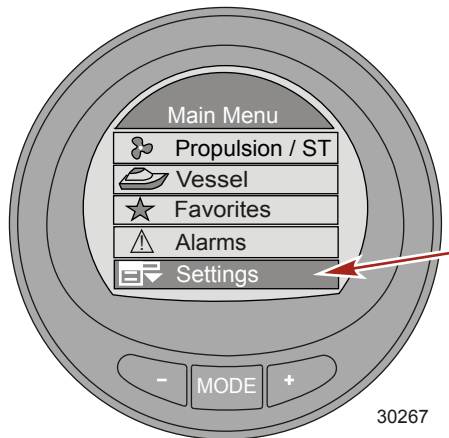

3. Press the "-" button to highlight the "Screens" menu.

# SETTINGS

4. Press the "MODE" button to edit the "Screens" menu.

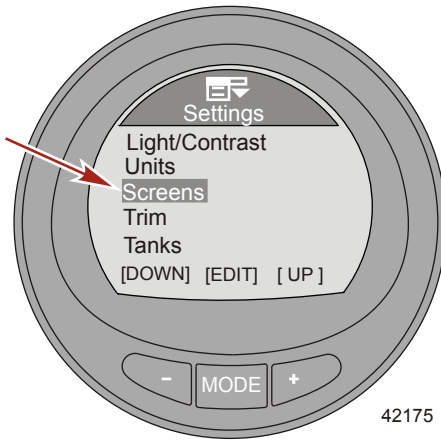

5. Press the "MODE" button to edit the "Full Screens" menu.

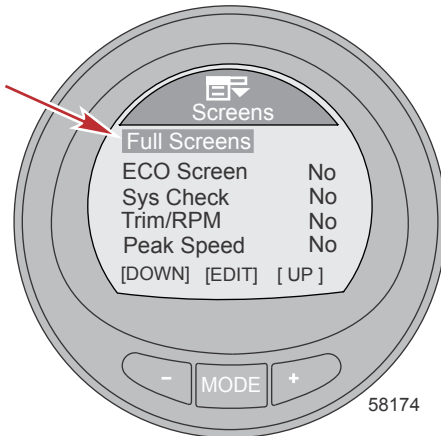



# SETTINGS

6. Press the "MODE" button to turn the "Speed" option on ("Yes") or off ("No").

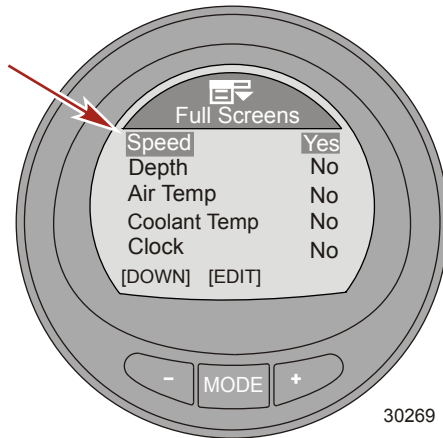

7. Press the "-" button to highlight the "Depth" option.
8. Press the "MODE" button to turn the "Depth" option on ("Yes") or off ("No").

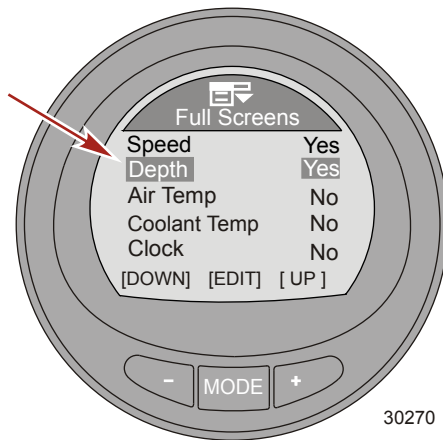

9. Press the "-" button to highlight the "Air Temp" option.

# SETTINGS

10. Press the "MODE" button to turn the "Air Temp" option on ("Yes") or off ("No").

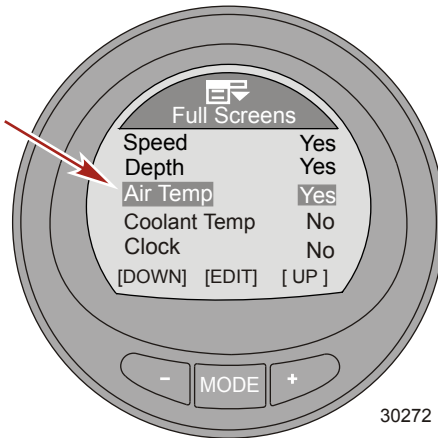

11. Press the "-" button to highlight the "Coolant Temp" option.
12. Press the "MODE" button to turn the "Coolant Temp" option on ("Yes") or off ("No").

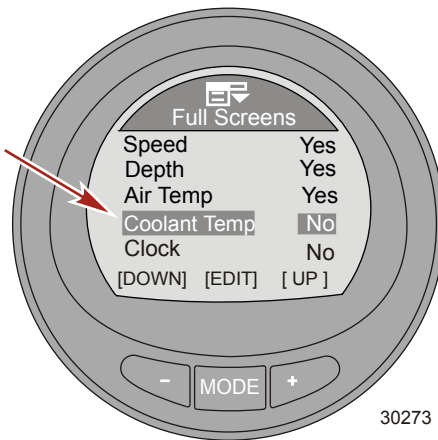

13. Press the "-" button to highlight the "Clock" option.

# SETTINGS

14. Press the "MODE" button to edit the "Clock" option to off ("No"). Press the "MODE" button again to change the clock to an "Analog" display, or press the "MODE" button again to change the display to "Digital."

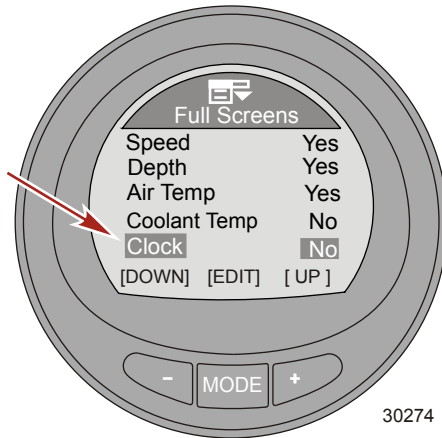

15. Press the "-" button to highlight the "Oil Temp" option.
16. Press the "MODE" button to turn the "Oil Temp" option on ("Yes") or off ("No").

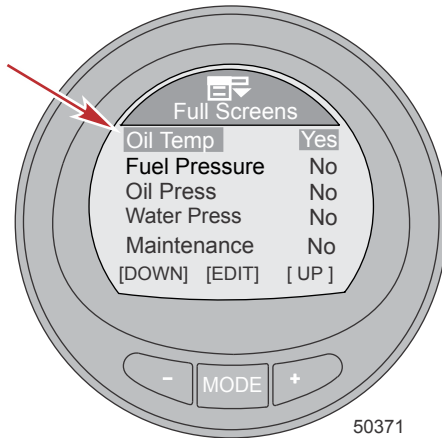

17. Press the "-" button to highlight the "Fuel Pressure" option.

# SETTINGS

18. Press the "MODE" button to turn the "Fuel Pressure" option on ("Yes") or off ("No").

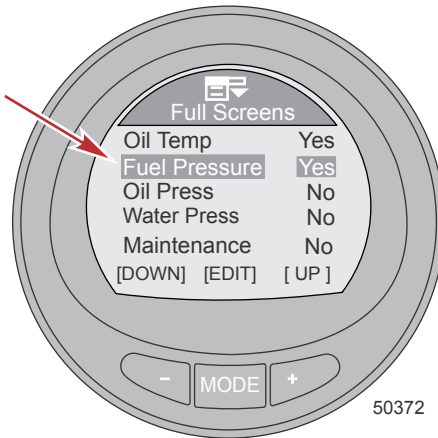

19. Press the "-" button to highlight the "Oil Press" option.  
20. Press the "MODE" button to turn the "Oil Press" option on ("Yes") or off ("No").

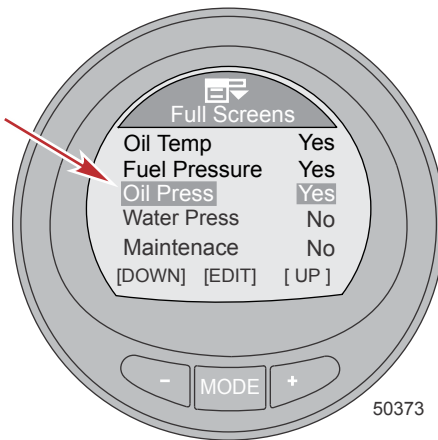

21. Press the "-" button to highlight the "Water Press" option.

# SETTINGS

22. Press the "MODE" button to turn the "Water Press" option on ("Yes") or off ("No").

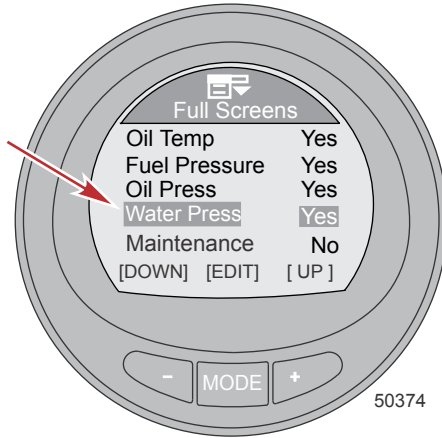

23. Press the "-" button to highlight the "Maintenance" option.
24. Press the "MODE" button to turn the "Maintenance" option on ("Yes") or off ("No").

**NOTE:** This screen option must be turned on ("Yes") to monitor the 100 hour maintenance schedule.

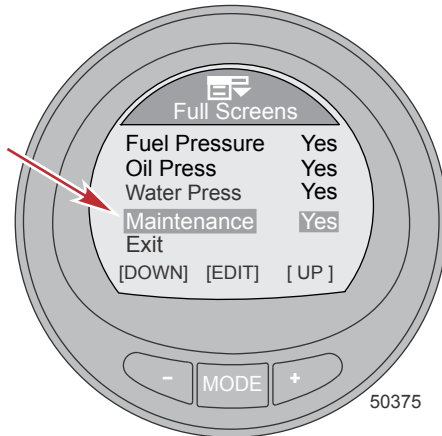

25. Press the "-" button to highlight the "Exit" option.
26. Press the "MODE" button to exit the "Full Screens" option.

## ADDITIONAL SCREENS OPTIONS

1. While in the "Screens" menu, press the "-" button to highlight the "ECO Screen" option.

# SETTINGS

2. Press the "MODE" button to turn the option on ("Yes") or off ("No").

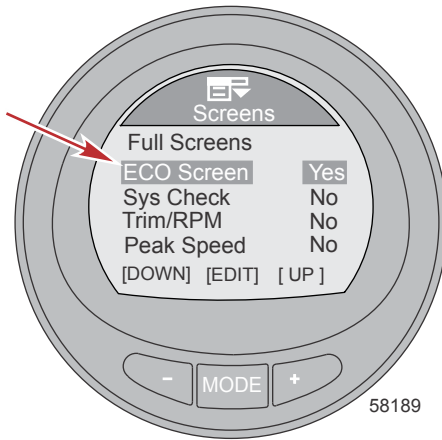

3. Press the "-" button to highlight the "Sys Check" option.
4. Press the "MODE" button to turn the option on ("Yes") or off ("No").

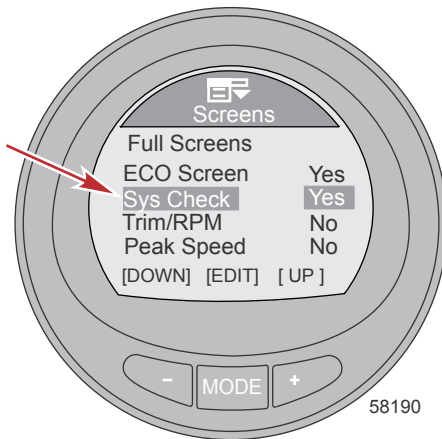

5. Press the "-" button to highlight the "Trim/RPM" option.

# SETTINGS

6. Press the "MODE" button to turn the option on ("Yes") or off ("No").

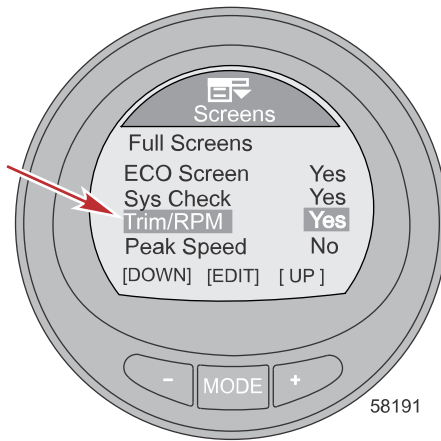

7. Press the "-" button to highlight the "Peak Speed" option.
8. Press the "MODE" button to turn the option on ("Yes") or off ("No").

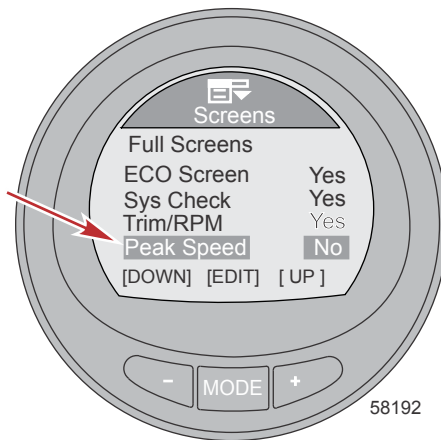

9. Press the "-" button to highlight the "Water Info" option.

# SETTINGS

10. Press the "MODE" button to turn the option on ("Yes") or off ("No").

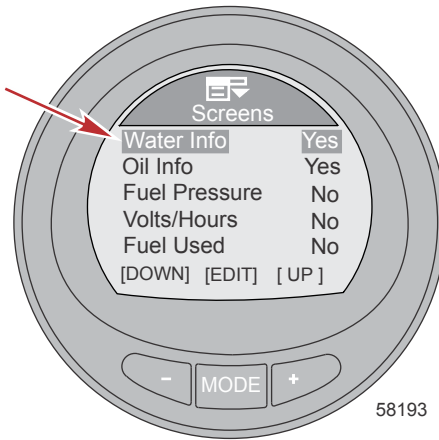

11. Press the "-" button to highlight the "Oil Info" option.

12. Press the "MODE" button to turn the option on ("Yes") or off ("No").

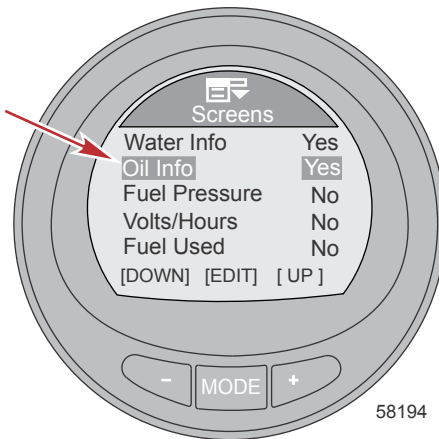

13. Press the "-" button to highlight the "Fuel Pressure" option.



# SETTINGS

14. Press the "MODE" button to turn the option on ("Yes") or off ("No").

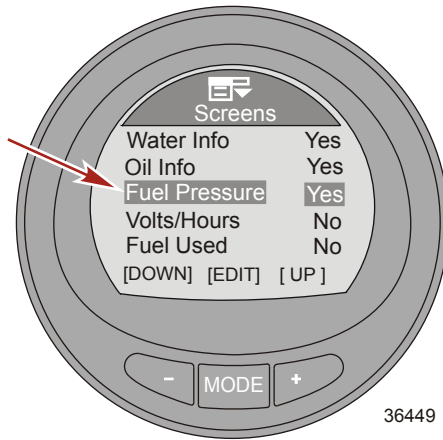

15. Press the "-" button to highlight the "Volts/Hours" option.  
16. Press the "MODE" button to turn the option on ("Yes") or off ("No").

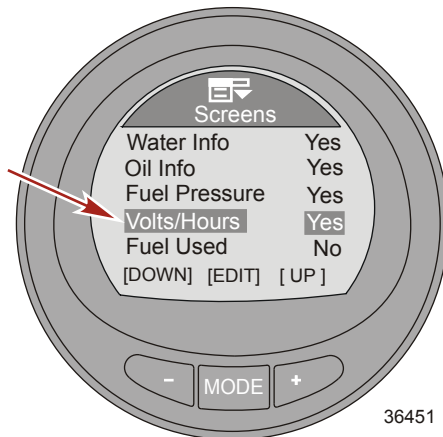

17. Press the "-" button to highlight the "Fuel Used" option.

# SETTINGS

18. Press the "MODE" button to turn the option on ("Yes") or off ("No").

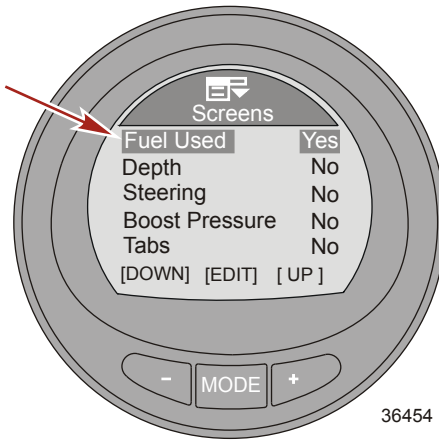

19. Press the "-" button to highlight the "Depth" option.

20. Press the "MODE" button to turn the option on ("Yes") or off ("No").

**NOTE:** The "Depth" screen must be turned on to enable the depth alarms.

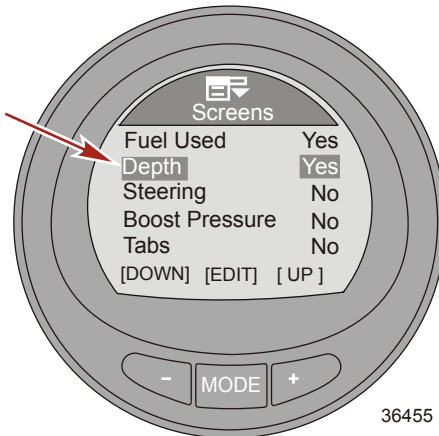

21. Press the "-" button to highlight the "Steering" option.

# SETTINGS

22. Press the "MODE" button to turn the option on ("Yes") or off ("No").

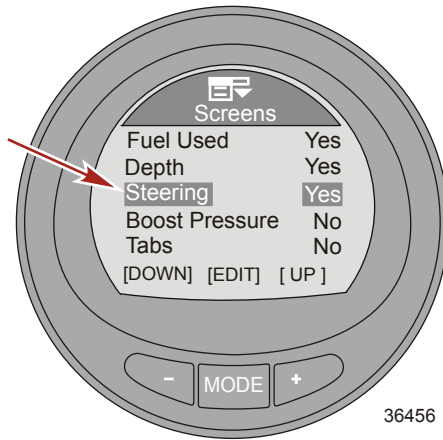

23. Press the "-" button to highlight the "Boost Pressure" option.

24. Press the "MODE" button to turn the option on ("Yes") or off ("No").

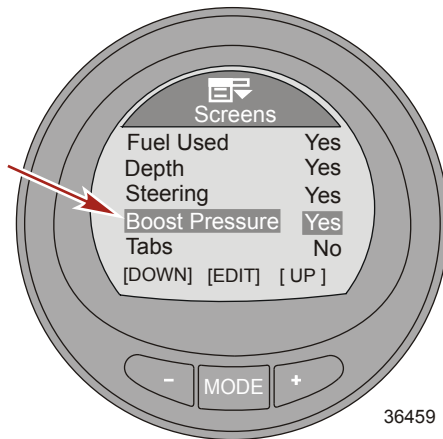

25. Press the "-" button to highlight the "Tabs" option.

# SETTINGS

26. Press the "MODE" button to turn the option on ("Yes") or off ("No").

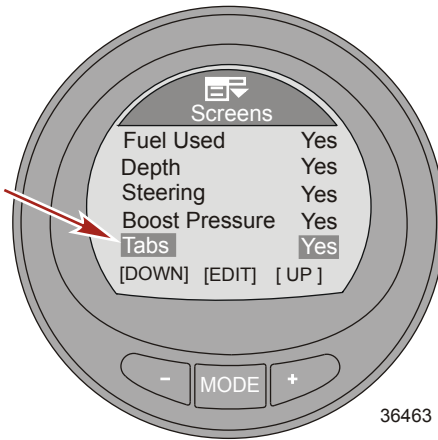

**NOTE:** The following screens are not editable and are not functional with the ECO gauge—"GPS Data," "Waypoint," and "Generator."

27. Press the "-" button to highlight the "Troll Control" option.

**NOTE:** This option is not accessible when the power package is not capable of troll control.

28. Press the "MODE" button to turn the option on ("Yes") or off ("No").

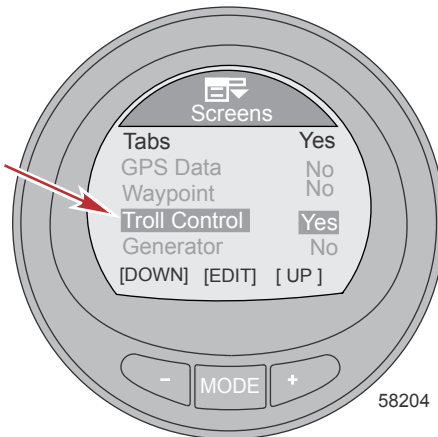

29. Press the "-" button to highlight the "Screen Sync" option.

# SETTINGS

30. Press the "MODE" button to turn the option on ("Yes") or off ("No").

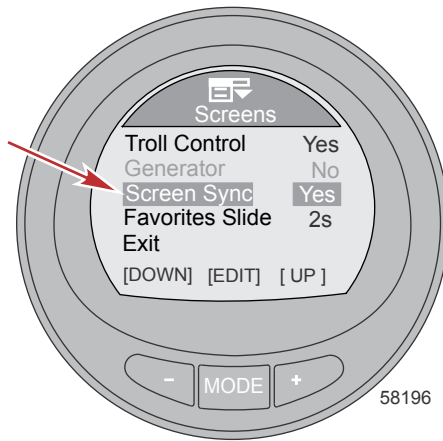

31. Press the "-" button to highlight the "Favorites Slide" option.

**NOTE:** The "Favorites Slide" seconds must be displayed for the "Favorites" screen transition to function. Select from 1–30 seconds to display the selected favorites. When the seconds are set to "OFF," the "Favorites" screen must be advanced manually using the mode button.

32. Press the "MODE" button to edit the number of seconds the favorites will display.  
33. Press the "+" or "-" to change the number of seconds.

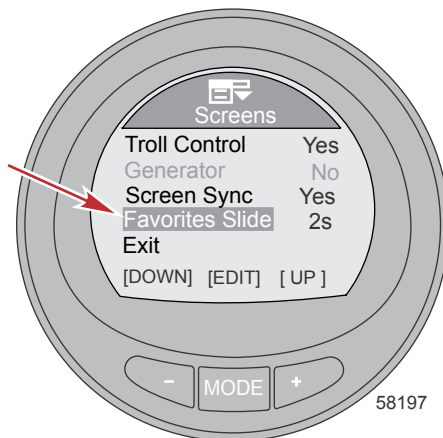

34. Press the "MODE" button to exit the "Favorites Slide" option.  
35. Press the "-" button to highlight the "Exit" option. Press the "MODE" button to exit the "Screens" menu.

# SETTINGS

## Setting the Trim

Editing the trim settings menu allows you to turn the trim pop-up on or off, change the length of time the pop-up window remains on the screen, turn the high resolution on or off, and calibrate the gauge to the sensor. A high resolution setting will cause the monitor to display the trim position with more detailed information.

1. While in the "Main Menu," press the "-" or "+" button to highlight the "Settings" menu.
2. Press the "MODE" button to enter the "Settings" menu.

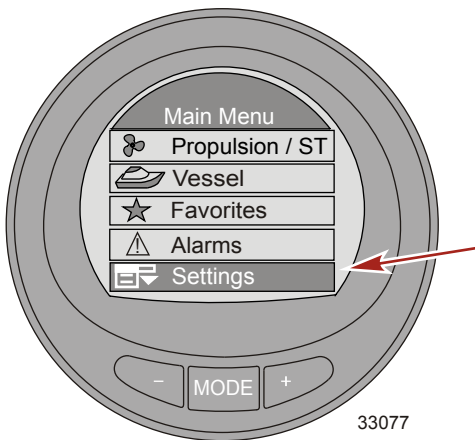

3. Press the "-" button to highlight the "Trim" menu.
4. Press the "MODE" button to edit the "Trim" menu.

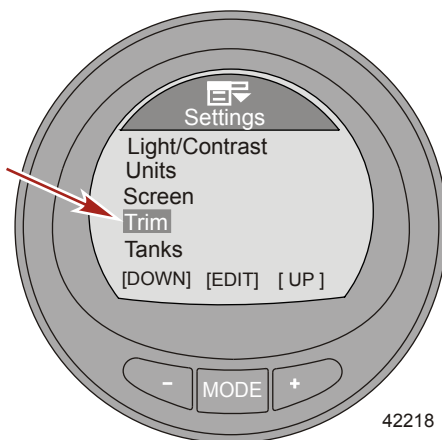

# SETTINGS

5. Press the "MODE" button to turn the trim "Popup" window option on ("Yes") or off ("No").

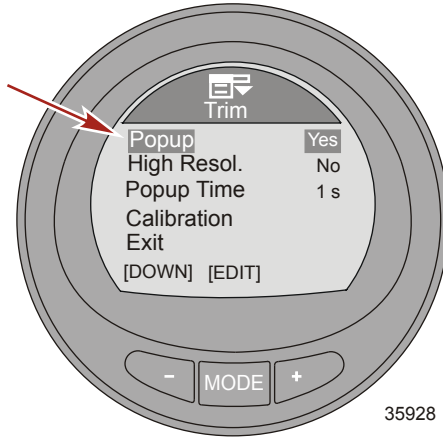

6. Press the "-" button to highlight the "High Resol" option.
7. Press the "MODE" button to turn the high resolution option on ("Yes") or off ("No").

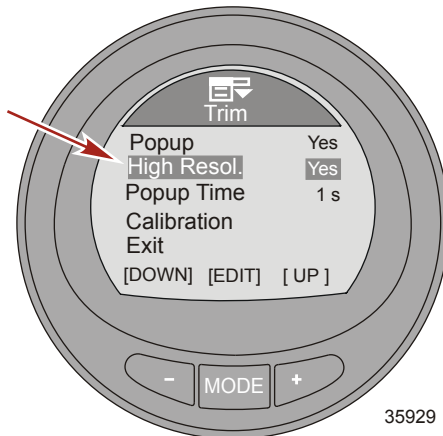

8. Press the "-" button to highlight the "Popup Time" option.
9. Press the "MODE" button to edit the length of time the trim pop-up window option remains on the screen.

# SETTINGS

10. Press the "-" or "+" to change the length of time the trim pop-up window option remains on the screen. The trim pop-up window length of time can be changed from 1–10 seconds.

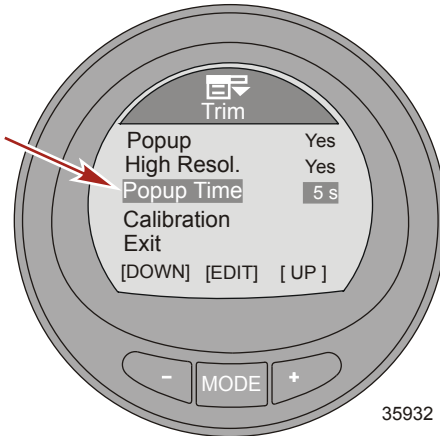

11. Press the "MODE" button to exit the "Popup Time" option.
12. Press the "-" button to highlight the "Calibration" option.
13. Press the "MODE" button to calibrate the gauge to the trim position sensor. An instruction window will popup stating to trim full down and press the "+" button when ready.



14. After pressing the "+" button, the pop-up window instructions will change stating to trim full up and press the "+" button when ready.



# SETTINGS

**IMPORTANT:** To achieve accurate trim full up calibration, this must be performed on the water while the vessel is running at cruising speed. While at cruising speed, trim up to the maximum trim angle before the vessel begins to porpoise, then press the "+" button.

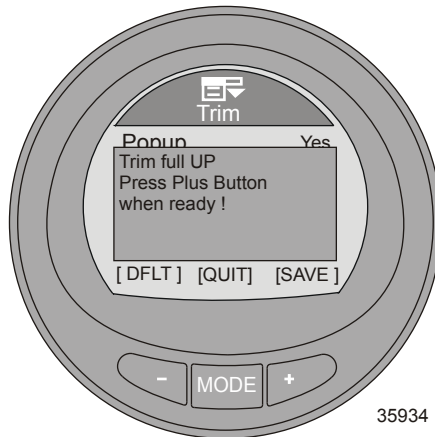

15. After pressing the "+" button, the pop-up window instructions will change stating to trim to the trailer point and press the "+" button when ready.

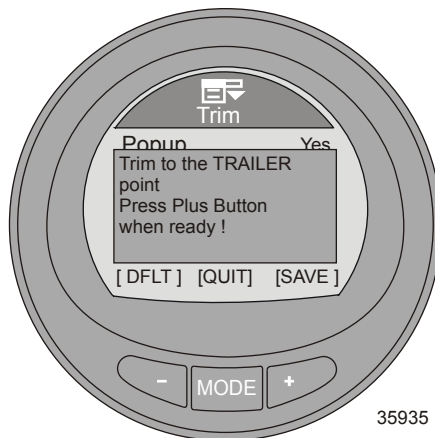

16. Press the "+" button to return to the "Calibration" option.
17. Press the "-" button to highlight the "Exit" option. Press the "MODE" button to return to the "Settings" menu.
18. Press the "-" button to highlight the "Exit" option. Press the "MODE" button to return to the "Main Menu" screen.

# SETTINGS

## Setting the Tanks

There are two tanks available for each power package installed on the vessel. Tank number "1" can be designated as not installed ("Not inst") or fuel. When "Not inst" is selected, the options for setting the tank capacity and the calibration cannot be edited. The maximum fuel capacity is 2271 liter (600 US gal). The second tank can be designated as not installed ("Not inst"), water, fuel, or waste on 4-stroke engines and will automatically default to oil if the gauge is installed on a vessel with a 2-stroke engine.

Two different methods are available to calibrate the tanks. For linear shaped fuel tanks, choose "Default Calibration." "Default Calibration" assumes the tank is uniformly shaped and that each quarter of the tank holds a quarter of its total capacity. Water and waste tanks are typical to this linear shape tank and are automatically set to the "Default Calibration." For irregularly shaped fuel tanks, choose "Add Fuel Method." Fuel must be added to the tank for each quarter of the capacity when using this method. The "Add Fuel Method" should be performed in the water for an accurate representation of the tank capacity.

**NOTE:** Tank capacity must be calibrated by either the "Default Calibration," or "Add Fuel Method," or the capacity will revert back to its former value.

### TANK 1

1. While in the "Main Menu," press the "-" or "+" button to highlight the "Settings" menu.
2. Press the "MODE" button to enter the "Settings" menu.

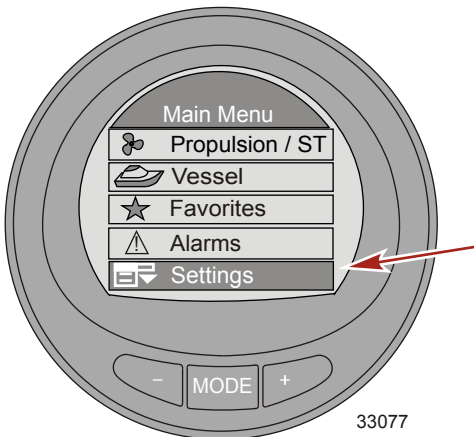

3. Press the "-" button to highlight the "Tanks" menu.

# SETTINGS

4. Press the "MODE" button to edit the "Tanks" menu.

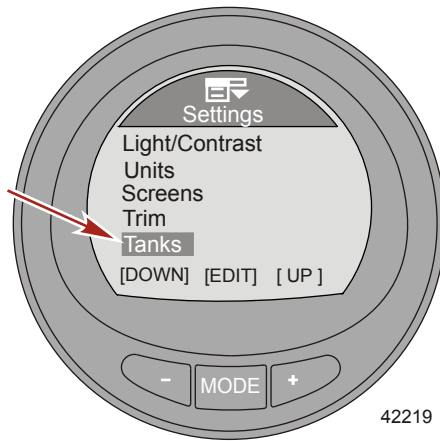

5. Press the "MODE" button to edit the "Tank 1 Type" option.
6. Press the "-" or "+" button to change the tank setting.

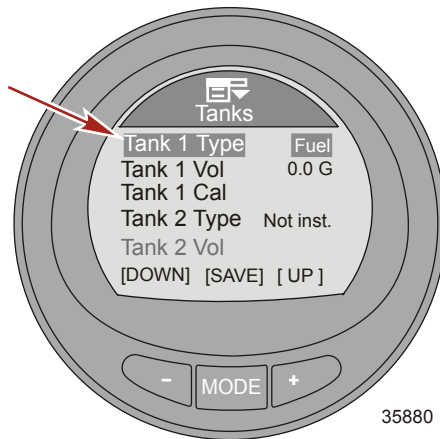

7. Press the "MODE" button to exit the "Tank 1 Type" option.
8. Press the "-" button to highlight the "Tank 1 Vol" capacity.
9. Press the "MODE" button to edit the capacity.

**NOTE:** The maximum capacity is 2271 liter (600 US gal).

# SETTINGS

- Press the "-" or "+" button to change the capacity of the tank. Holding the button down will scroll through the numbers.

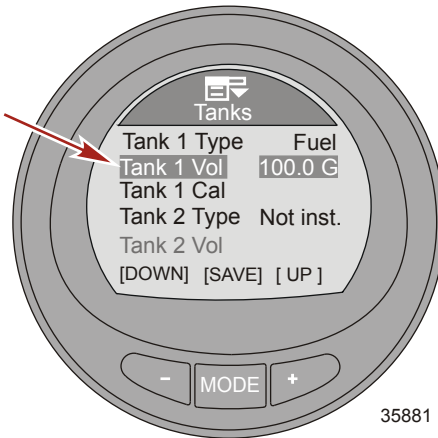

- Press the "MODE" button to exit the "Tank 1 Vol" option.
- Press the "-" button to highlight the "Tank 1 Cal" option.

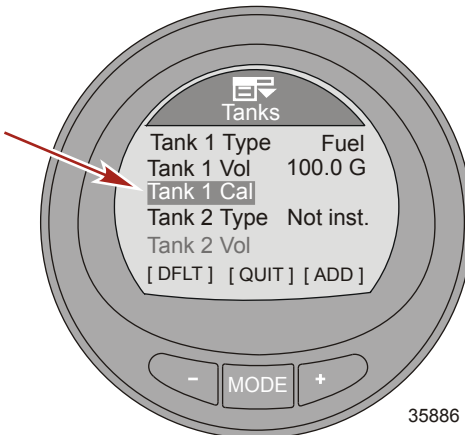

- Press the "MODE" button to select the type of calibration.

**NOTE:** Two different methods are available to calibrate the tanks: For linear shaped fuel tanks, choose "Default Calibration." "Default Calibration" assumes the tank is uniformly shaped and that each quarter of the tank holds a quarter of its total capacity. Water and waste tanks are typical to this linear shape tank. For irregularly shaped fuel tanks, choose "Add Fuel Method." Fuel must be added to the tank for each quarter of the capacity when using this method. The "Add Fuel Method" should be performed in the water for an accurate representation of the tank capacity.

# SETTINGS

**NOTE:** The following procedure is used for the "Default Calibration" method.

14. Press the "-" button to choose the "Default Calibration" method or press the "MODE" button to quit the calibration.

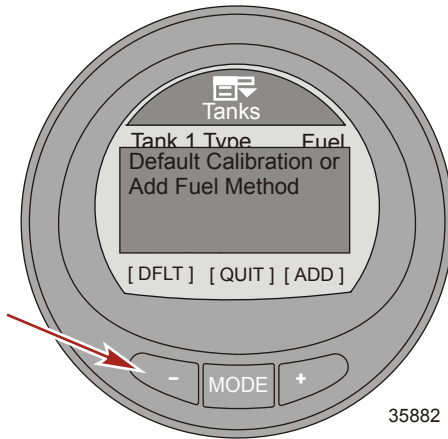

15. Press the "MODE" button to finish "(OK)" and exit the "Tank 1 Cal" option.

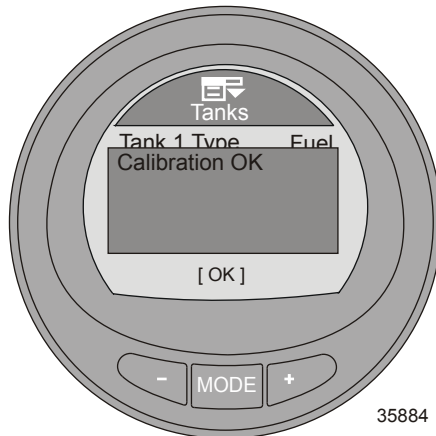

**NOTE:** The following procedure is used for the "Add Fuel Method" of calibration.

# SETTINGS

16. Press the "+" button to choose the "Add Fuel Method" or press the "MODE" button to quit the calibration.

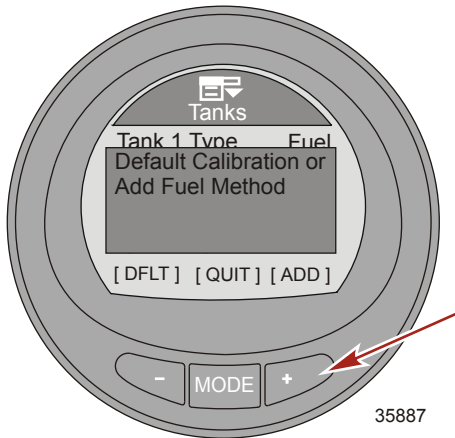

17. Press the "+" button to save and edit the "Add Fuel Method" of calibration.

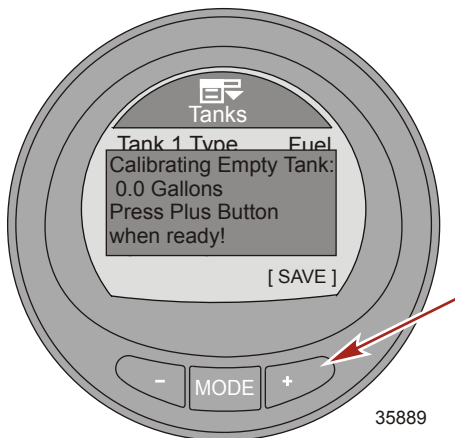

# SETTINGS

18. Add 25 percent of the fuel capacity to the empty fuel tank. The gauge will list the quantity of fuel to add for each quarter. Press the "+" button to save the calibration.

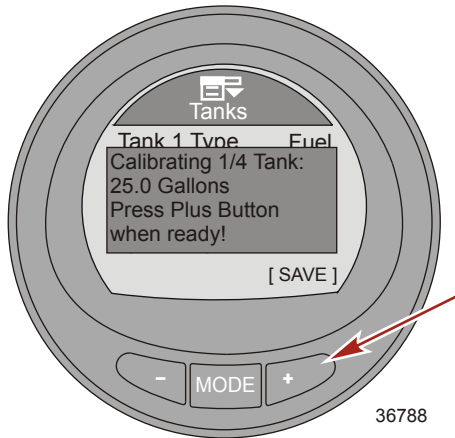

19. The fuel level sensor must change a minimal value when adding fuel. If the fuel level sensor does not change to the minimal value any time during the add fuel calibration, an error message stating the calibration is defaulting to values ("Error! Defaulting to values...") will be visible on the screen. The manual calibration process will stop when the error message appears. The fuel tank must be emptied and the manual calibration process must be repeated.

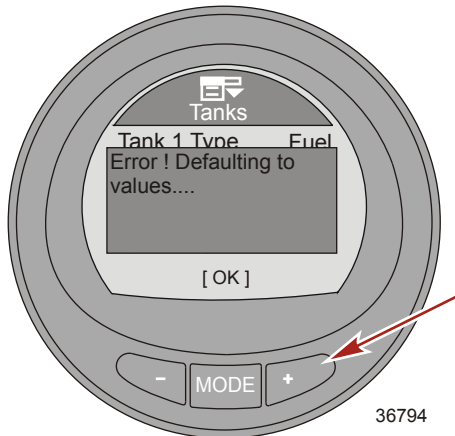

# SETTINGS

20. Add 25 percent more fuel capacity to the fuel tank. Press the "+" button to save the calibration.

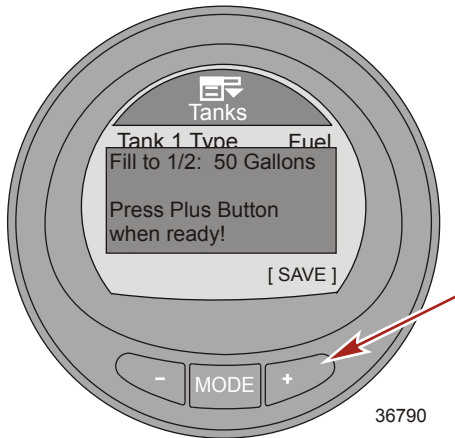

21. Add 25 percent more fuel capacity to the fuel tank. Press the "+" button to save the calibration.

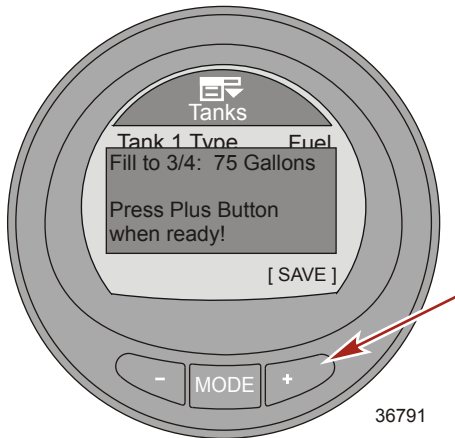



# SETTINGS

22. Add 25 percent more fuel capacity to fill the fuel tank. Press the "+" button to save the calibration.

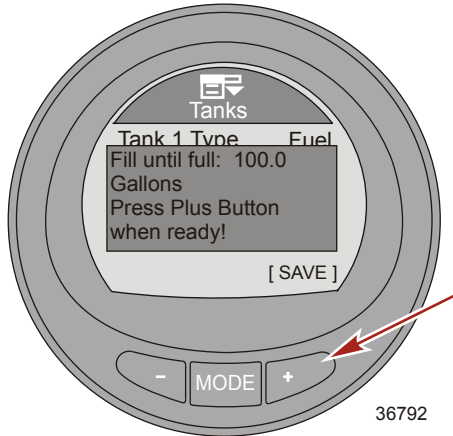

23. The screen on the monitor will state the fuel tank calibrations is successful ("Calibrations OK").

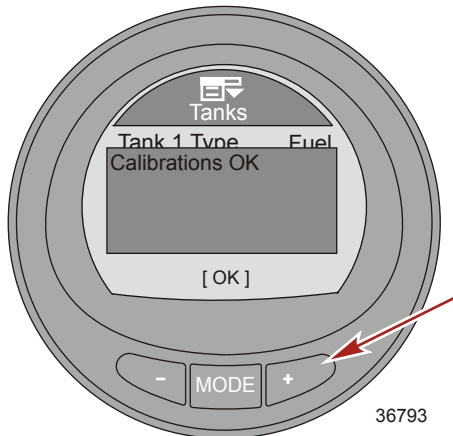

24. Press the "MODE" button to exit the calibration process.  
25. Press the "-" button to edit the "Tank 2 Type" option.

# SETTINGS

## TANK 2

The second tank can be designated as not installed ("Not inst"), water, fuel, or waste when installed on a vessel with a 4-stroke engine. The maximum fuel capacity is 2271 liter (600 US gal). When the tank is designated as water or waste, the calibration is automatically selected as default and will estimate the level based on a linear shape capacity and the calibration cannot be edited. When fuel is selected for tank 2, the calibration methods are the same as tank 1. Choose between the "Default Calibration" method or "Add Fuel Method."

When the gauge is installed on a vessel with a 2-stroke engine, the second tank will default to oil automatically and cannot be calibrated.

## Setting the Alarms

Alarm settings can be customized to the vessel specifications and to the preference of the owner. Low fuel and critical fuel levels cannot be disabled, but can be adjusted to the preference of the owner. These levels can be adjusted down to 10 percent of the fuel tank volume. The shallow water depth, deep water depth, and waypoint distance alarms can be turned off or on. The shallow water depth alarm can be adjusted to 0.1 m (0.3 ft) and the deep water depth alarm can be adjusted to 300 m (984 ft). The pop-up alarm warning for these settings can be turned off or on.

1. While in the "Main Menu," press the "-" or "+" button to highlight the "Settings" menu.
2. Press the "MODE" button to enter the "Settings" menu.

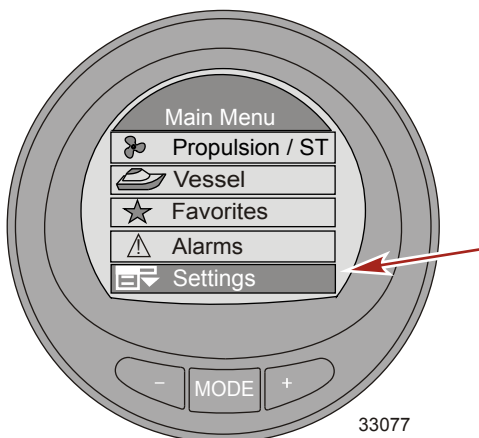

3. Press the "-" button to highlight the "Alarms" menu.

# SETTINGS

4. Press the "MODE" button to edit the "Alarms" menu.

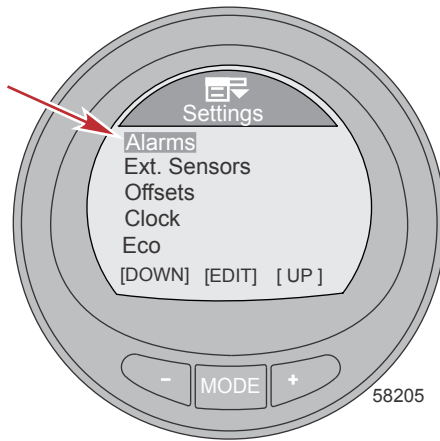

5. Press the "MODE" button to enter the "Fuel Critical" option.
6. Press the "-" or "+" to edit the "Fuel Critical" percentage. This percentage cannot be set lower than 10, or more than the "Fuel Low" alarm setting.

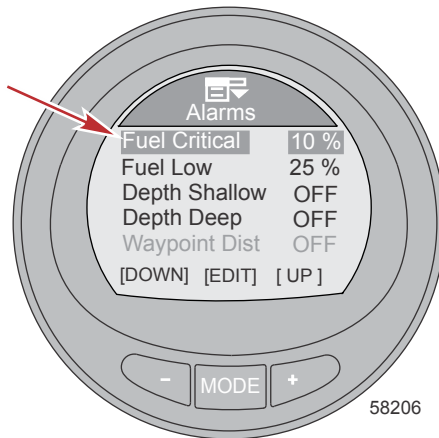

7. Press the "MODE" button to exit the "Fuel Critical" option.
8. Press the "-" button to highlight the "Fuel Low" option.
9. Press the "MODE" button to enter the "Fuel Low" option.

# SETTINGS

10. Press the "-" or "+" to edit the "Fuel Low" percentage. This percentage cannot be set lower than 10, or more than 50 percent.

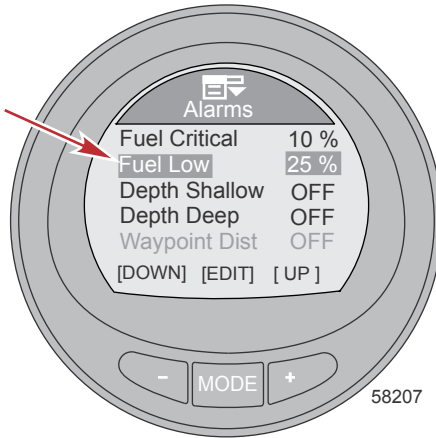

11. Press the "MODE" button to exit the "Fuel Low" option.
12. Press the "-" button to highlight the "Depth Shallow" option.
13. Press the "MODE" button to enter the "Depth Shallow" option.
14. Press the "-" or "+" to edit the "Depth Shallow" option. The minimum setting is 0.1 m (0.3 ft) and the maximum setting is 100 m (328 ft).

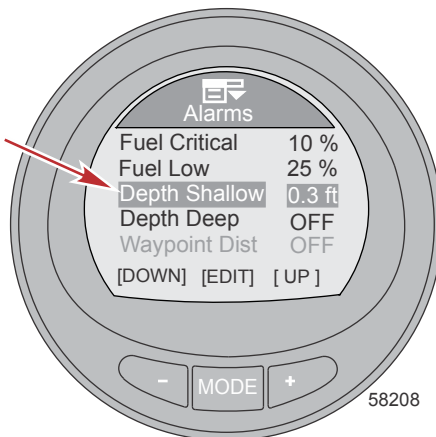

15. Press the "MODE" button to exit the "Depth Shallow" option.
16. Press the "-" button to highlight the "Depth Deep" option.
17. Press the "MODE" button to enter the "Depth Deep" option.
18. Press the "-" or "+" to edit the "Depth Deep" option. The minimum setting is 0.2 m (0.7 ft) and the maximum setting is 300 m (984 ft).

# SETTINGS

**NOTE:** The minimum setting can be set to 0.1 m (0.3 ft) when the "Depth Shallow" is set to "OFF."

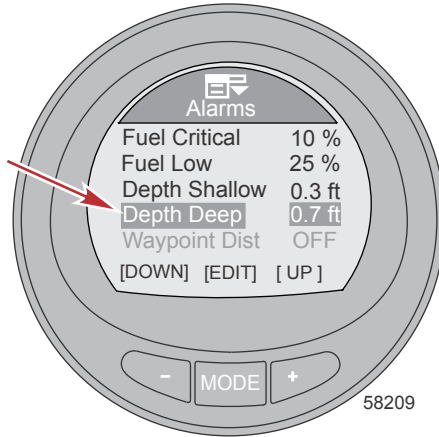

19. Press the "MODE" button to exit the "Depth Deep" option.

**IMPORTANT:** "Waypoint Dist," "Generator," and "HVAC System" are not editable.

20. Press the "-" button to highlight the "Popup" option.

21. Press the "MODE" button to turn the option on ("Yes") or off ("No").

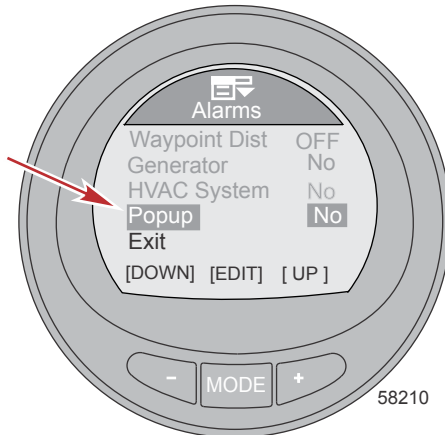

22. Press the "-" button to highlight the "Exit" option. Press the "MODE" button to exit the "Alarms" menu.

# SETTINGS

## Setting the External Sensors

The external sensors menu turns a number of sensors off or on. These include sea temperature, trim, GPS, speed, steering, and tabs. The external sensors menu also can change how the speed is recognized; pitot, paddle wheel, GPS, and at what speed the transition to a different sensor occurs. The type of pitot sensor can be changed from 689 kPa (100 psi) for most vessel applications, to a high-speed 1379 kPa (200 psi) sensor. A high-speed sensor must be installed for an accurate speed to be displayed when the 1379 kPa (200 psi) is selected.

1. While in the "Main Menu," press the "-" or "+" button to highlight the "Settings" menu.
2. Press the "MODE" button to enter the "Settings" menu.

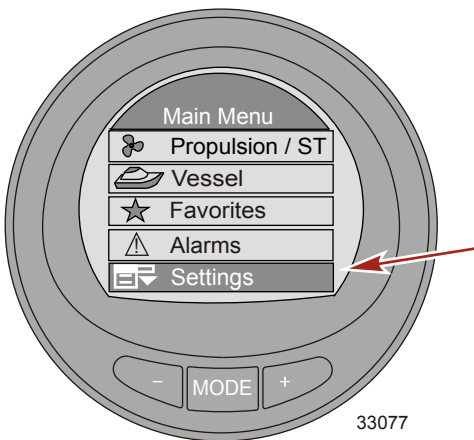

3. Press the "-" button to highlight the "Ext. Sensors" menu.

# SETTINGS

4. Press the "MODE" button to edit the "Ext. Sensors" menu.

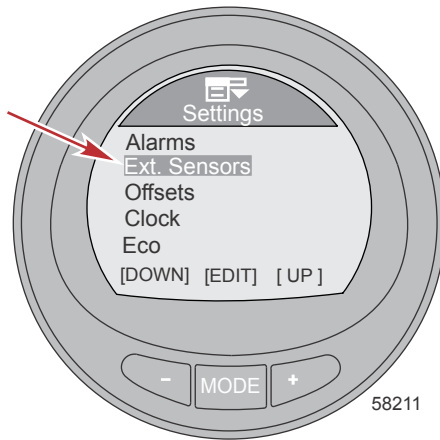

5. Press the "MODE" button to turn the "Depth/Seatemp" option on ("Yes") or off ("No").

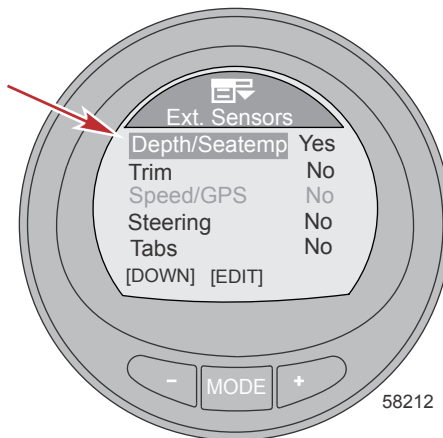

6. Press the "-" button to highlight the "Trim" option.

# SETTINGS

7. Press the "MODE" button to turn the option on ("Yes") or off ("No").

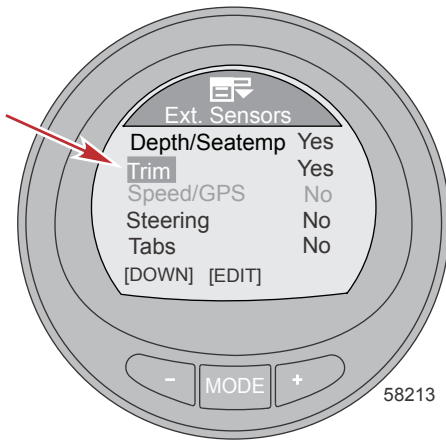

8. Press the "-" button to highlight the "Speed/GPS" option.
9. Press the "MODE" button to edit the "Speed/GPS" options.

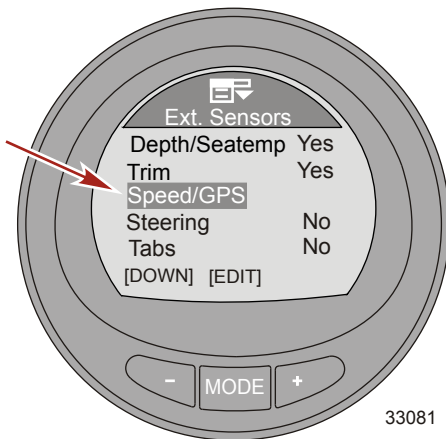



# SETTINGS

10. Press the "MODE" button to turn the "Use Paddle" option on ("Yes") or off ("No").

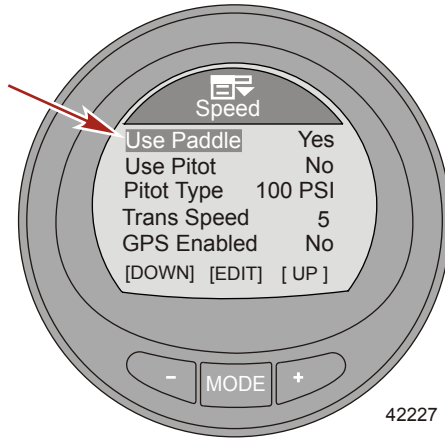

11. Press the "-" button to highlight the "Use Pitot" option.
12. Press the "MODE" button to turn the option on ("Yes") or off ("No").

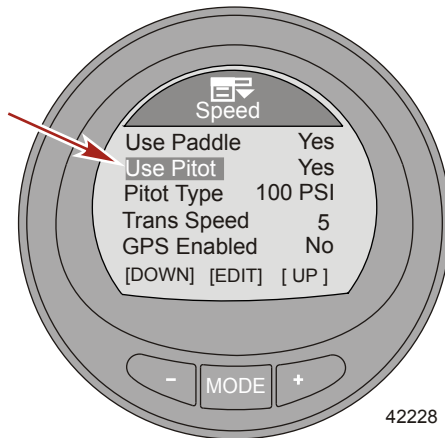

13. Press the "-" button to highlight the "Pitot Type" option.

# SETTINGS

14. Press the "MODE" button to change the sensor to "100 PSI" or "200 PSI."

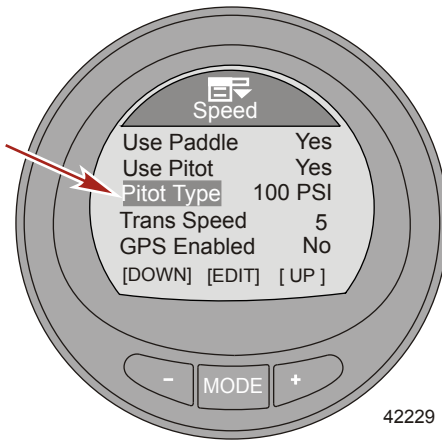

15. Press the "-" button to highlight the "Trans Speed" option.
16. Press the "MODE" button to edit the "Trans Speed" option.
17. Press the "-" or "+" button to change the speed where the paddle wheel sensor transitions to the pitot or GPS. The transition speed can be changed from 8 km/h (5 MPH) to 56 km/h (35 MPH). Press the "MODE" button to exit the "Trans Speed" edit mode.

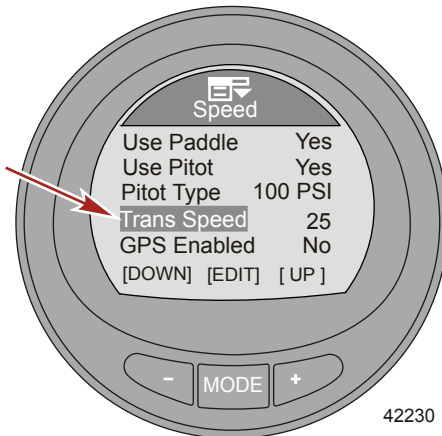

18. Press the "-" to highlight the "GPS Enabled" option.

# SETTINGS

19. Press the "MODE" button to turn the option on ("Yes") or off ("No").

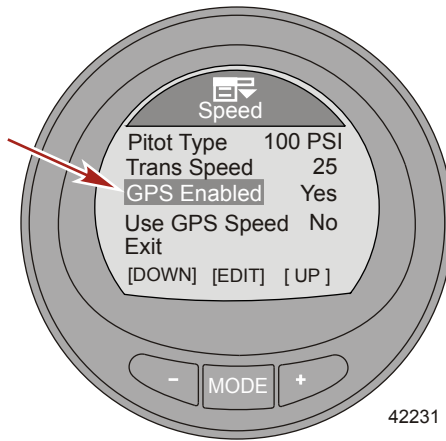

20. Press the "-" button to highlight the "Use GPS Speed" option.  
21. Press the "MODE" button to turn the option on ("Yes") or off ("No").

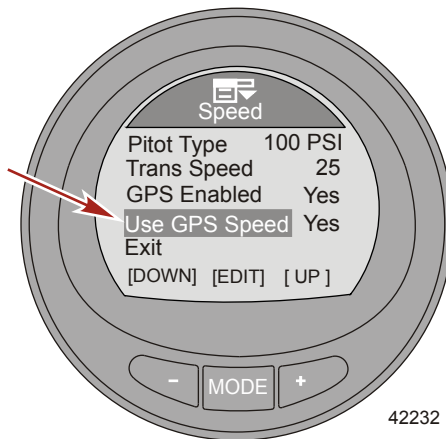

22. Press the "-" button to highlight the "Exit" option. Press the "MODE" button to exit the "Speed" menu.  
23. Press the "-" button to highlight the "Steering" option.

# SETTINGS

24. Press the "MODE" button to turn the option on ("Yes") or off ("No").

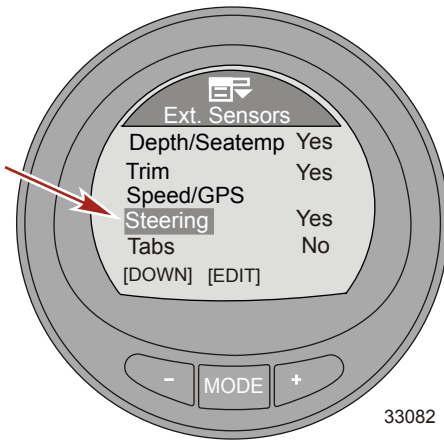

25. Press the "-" button to highlight the "Tabs" option.

26. Press the "MODE" button to turn the option on ("Yes") or off ("No").

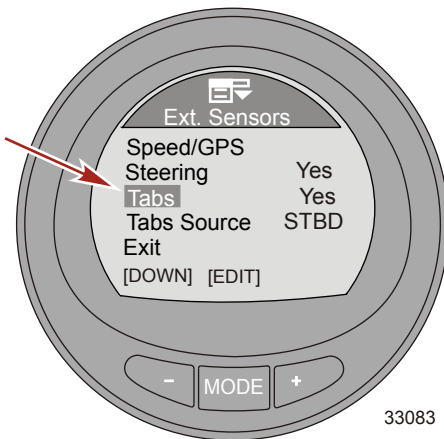

27. Press the "-" button to highlight the "Tabs Source" option.

28. Press the "MODE" button to edit the "Tabs Source" option.

# SETTINGS

**NOTE:** The "Tabs" option must be on ("Yes") for the "Tabs Source" to be activated. The "Tabs Source" will default to the engine location the gauge is set up to monitor. The engine location can be changed to starboard ("STBD"), port ("PORT"), starboard 2 ("STB2"), port 2 ("PRT2").

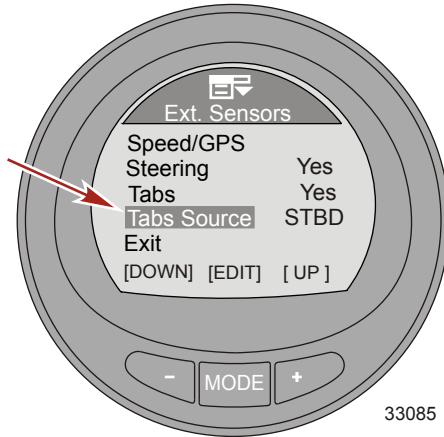

29. Press the "-" button to highlight the "Exit" option. Press the "MODE" button to exit the "Ext Sensors" menu.

## Setting the Offsets

The "Offsets" menu allows for compensation for inaccurate sensors, sets a transition speed from one speed sensor to another, inverts a steering sensor, and corrects the amount of fuel used. Sensors that can be modified are; sea temperature, depth, paddle wheel hertz, pitot pressure, and steering position.

1. While in the "Main Menu," press the "-" or "+" button to highlight the "Settings" menu.

# SETTINGS

2. Press the "MODE" button to enter the "Settings" menu.

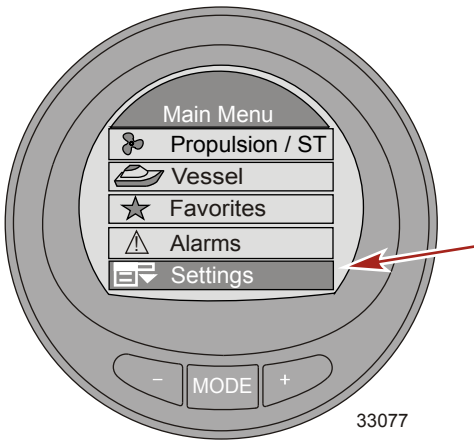

3. Press the "-" button to highlight the "Offsets" menu.
4. Press the "MODE" button to edit the "Offsets" menu.

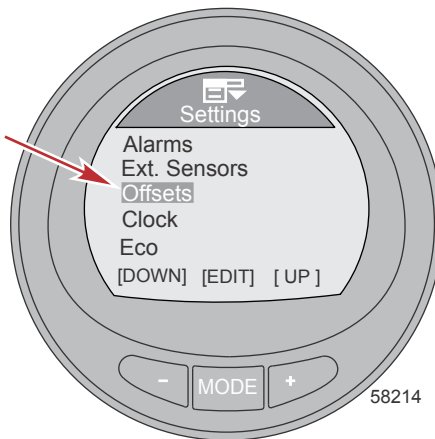

5. Press the "MODE" button to edit the "Seatemp" option.

# SETTINGS

6. Press the "-" or "+" button to change the sea temperature correction from -23.3 to -12.2 °C (-10 to 10 °F).

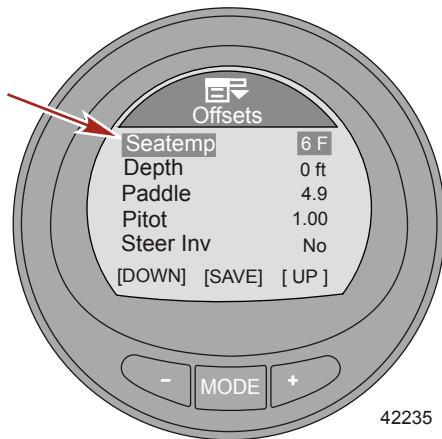

7. Press the "MODE" button to exit the "Seatemp" option.
8. Press the "-" button to highlight the "Depth" option.
9. Press the "MODE" button to edit the "Depth" option. The depth offset can be changed  $\pm 30.5$  m (100 ft).
10. Press the "-" or "+" button to change the depth offset.

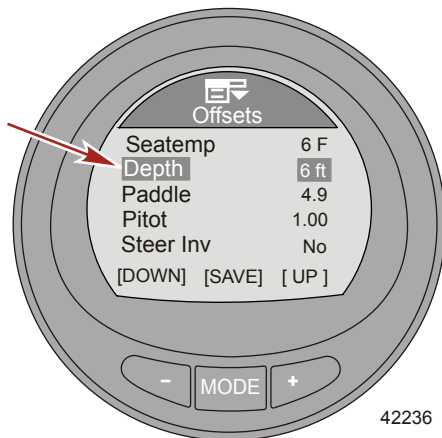

11. Press the "MODE" button to exit the "Depth" option.
12. Press the "-" button to highlight the "Paddle" option.
13. Press the "MODE" button to edit the "Paddle" option.

# SETTINGS

14. Press the "-" or "+" button to change the paddle offset. The offset can be changed from 3.4 Hz to 6.4 Hz.

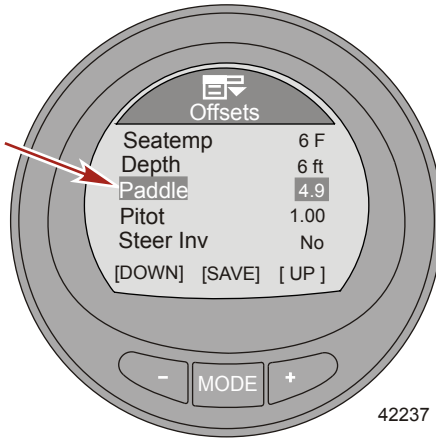

15. Press the "MODE" button to exit the "Paddle" option.  
16. Press the "-" button to highlight the "Pitot" option.  
17. Press the "MODE" button to edit the "Pitot" option.  
18. Press the "-" or "+" button to change the pitot offset. The offset can be changed from 0.50 to 1.50.

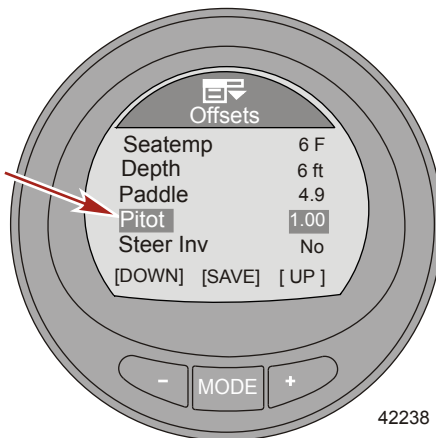

19. Press the "MODE" button to exit the "Pitot" option.  
20. Press the "-" button to highlight the "Steer Inv" option.



# SETTINGS

21. Press the "MODE" button to turn the option on ("Yes") or off ("No").

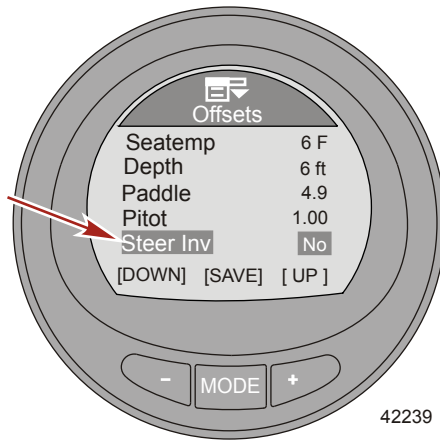

22. Press the "MODE" button to exit the "Steer Inv" option.  
23. Press the "-" button to highlight the "Steering" option.  
24. Press the "MODE" button to edit the "Steering" option.  
25. Press the "-" or "+" button to change the steering offset. The offset can be changed  $\pm 30$  degrees.

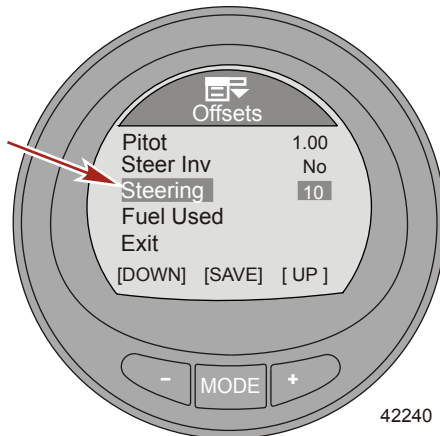

26. Press the "MODE" button to exit the "Steering" option.  
27. Press the "-" button to highlight the "Fuel Used" option.

# SETTINGS

28. Press the "MODE" button to edit the "Fuel Used" option.

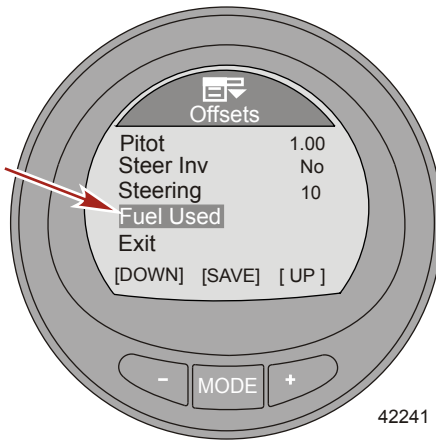

29. Press the "MODE" button to edit the "Multiplier" option.

30. Press the "-" or "+" button to change the multiplier offset. The offset can be changed from 0.50 to 1.50.

**NOTE:** The "Multiplier" is used to fine-tune the fuel gauge sender to correct for fuel used errors. If the gauge indicates that 10 gallons of fuel was used, but the actual fuel that was added is 14 gallons, change the multiplier to 1.40. If the gauge indicates that 10 gallons of fuel was used, but the actual fuel that was added is only 8 gallons, change the multiplier to 0.80.

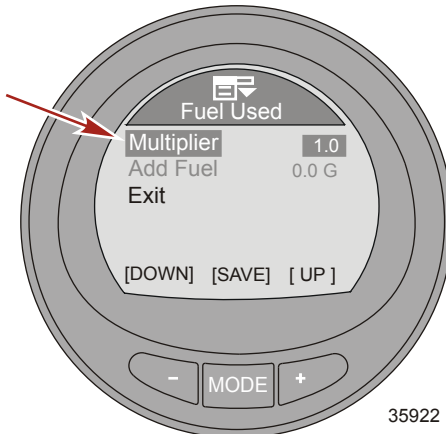

31. Press the "MODE" button to exit the "Multiplier" option.

32. Press the "-" button to highlight the "Add Fuel" option.

33. Press the "-" or "+" button to change the amount of fuel that was actually added to the fuel tank to correct for fuel capacity errors.

# SETTINGS

**NOTE:** The "Add Fuel" option functions the same as the multiplier. If the gauge indicates that 10 gallons of fuel was used, but the actual fuel that was added is 14 gallons, change the "Add Fuel" to 14.0. If the gauge indicates that 10 gallons of fuel was used, but the actual fuel that was added is only 8 gallons, change the "Add Fuel" to 8.0 gallons. The gauge will calculate the multiplier and will automatically change the number in the "Multiplier" option.

34. Press the "-" button to highlight the "Exit" option. Press the "MODE" button to exit the "Fuel Used" option.
35. Press the "-" button to highlight the "Exit" option. Press the "MODE" button to exit the "Offsets" menu.

## Setting the Clock

The "Clock" can be set to display a 24 hour day or a 12 hour (AM, PM) day. It can also be updated automatically when using a GPS. The GPS must be turned on ("Yes") in the external sensors ("Ext. Sensors") menu for the GPS menus to be enabled. The clock setting must have the "GPS Update" turned on ("Yes") for the universal time coordinated (UTC) to function. The UTC can be offset from -13 hours to +13 hours.

1. While in the "Main Menu," press the "-" or "+" button to highlight the "Settings" menu.
2. Press the "MODE" button to enter the "Settings" menu.

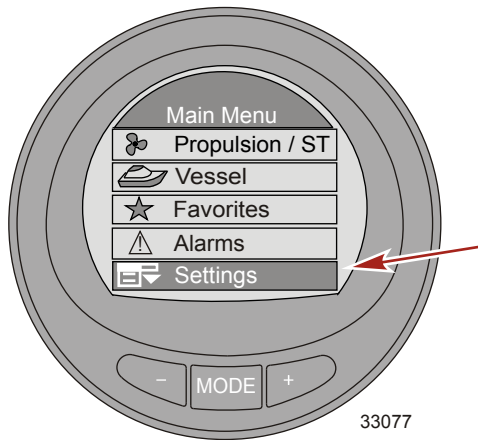

# SETTINGS

3. Press the "-" button to highlight the "Clock" menu.

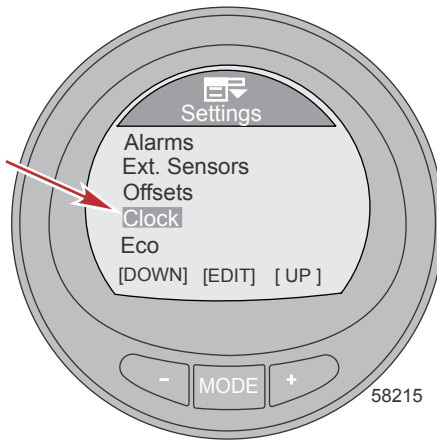

4. Press the "MODE" button to edit the "Clock" menu.
5. Press the "MODE" button to change the "Clock Format" option to 12 hour ("12h"), or 24 hour ("24h").

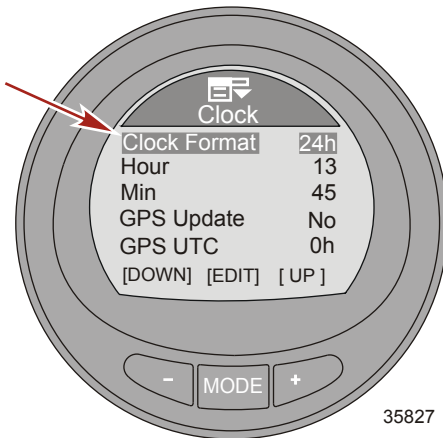

6. Press the "-" button to highlight the "Hour" option.
7. Press the "MODE" button to edit the "Hour" option.

# SETTINGS

8. Press the "-" or "+" button to edit the hour time.

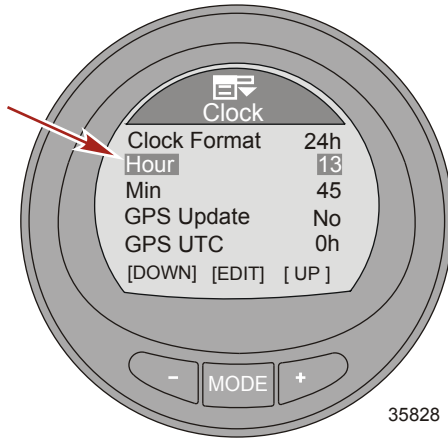

9. Press the "MODE" button to exit the hour edit mode.
10. Press the "-" button to highlight the "Min" option.
11. Press the "MODE" button to edit the "Min" option.
12. Press the "-" or "+" button to edit the minutes time.

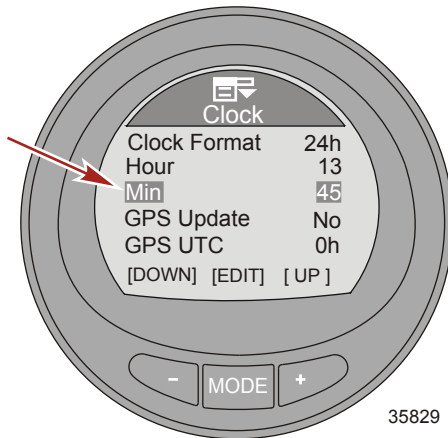

13. Press the "MODE" button to exit the minutes edit mode.

**NOTE:** A GPS must be connected to the monitor for the "GPS Update" to function, set waypoints, display GPS speed, UTC time, latitude, and longitude. A SmartCraft GPS puck must be installed to use the GPS speed based cruise control. If a GPS is not available, press the "-" button to highlight the "Exit" option. Press the "MODE" button to exit the clock menu.

14. Press the "-" button to highlight the "GPS Update" option.

# SETTINGS

15. Press the "MODE" button to change the option to on ("Yes") or off ("No").

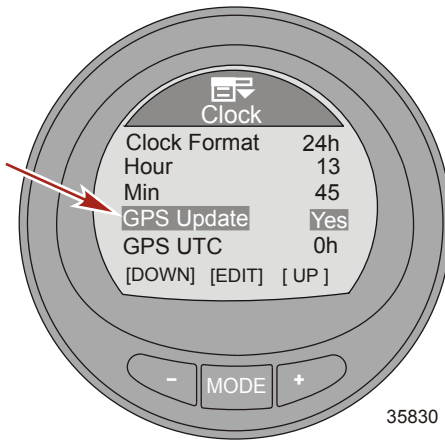

16. Press the "-" button to highlight the "GPS UTC" option.
17. Press the "MODE" button to edit the "GPS UTC" option.
18. Press the "-" or "+" button to edit the UTC offset time according to your vessel's location. The UTC can be offset from -13 hours to +13 hours.

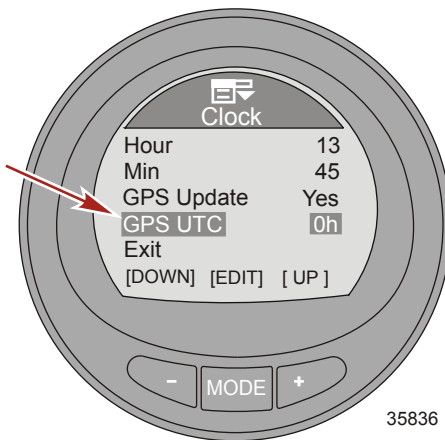

19. Press the "MODE" button to exit the "GPS UTC" option.
20. Press the "-" to highlight the "Exit" option and press the "MODE" button to exit the "Clock" menu.

# SETTINGS

## Economy (ECO) Settings

The software for the ECO screen monitors the engine sensors and looks for the best fuel economy while the vessel is in operation. When the software recognizes an improvement in the fuel economy, the gauge records what the trim and engine RPM values are at that time. This calculation happens whether the ECO screen is visible or not. When the software has recorded the RPM and trim values, it will guide the operator with arrows, to where that optimum running speed and trim setting was. **In most applications the ECO screen does not need any calibration**, although there are settings to customize the gauge for your boating style. The default settings are within acceptable parameters for most vessel applications.

**IMPORTANT: A manual trim calibration must be performed before the ECO screen can be used. Using a default trim calibration will not allow the ECO screen to function properly. The menu path is: "MAIN," > "Settings," > "Trim," > "Calibration."**

1. While in the "Main Menu," press the "-" or "+" button to highlight the "Settings" menu.
2. Press the "MODE" button to enter the "Settings" menu.

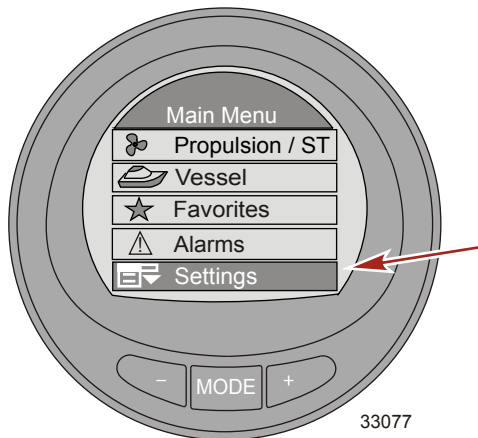

3. Press the "-" button to highlight the "ECO" menu.

# SETTINGS

**NOTE:** The default settings are within acceptable parameters for most vessel applications.

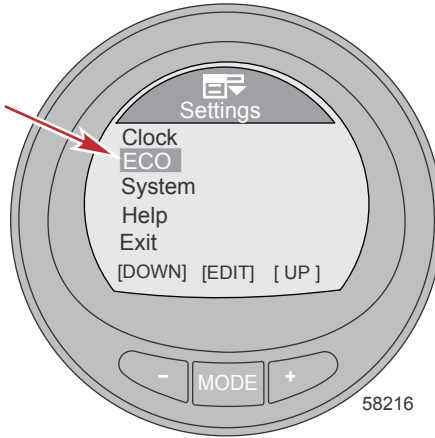

4. Press the "MODE" button to edit the "ECO" menu.
5. Press the "MODE" button to edit the "Min. RPM" option.
  - "Min. RPM" – Is used to customize the gauge for your boating style. This is the lowest RPM value the engine needs to achieve for the gauge to begin monitoring for the best fuel economy. The default setting is 2300 RPM.
6. Press the "-" or "+" button to change the minimum RPM.

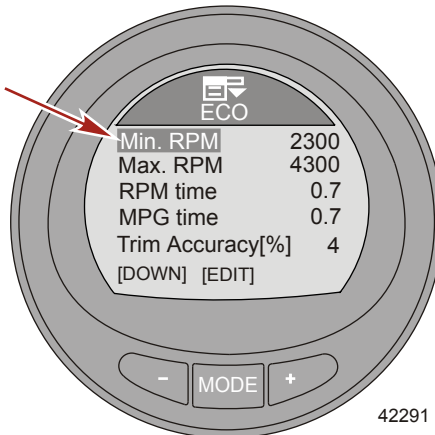

7. Press the "MODE" button to exit the "Min. RPM" edit option.
8. Press the "-" button to highlight the "Max. RPM" option.
9. Press the "MODE" button to edit the "Max. RPM" option.



# SETTINGS

- "Max. RPM" – Is used to customize the gauge for your boating style. This is the highest RPM value the engine needs to achieve for the gauge to stop monitoring for the best fuel economy. The default setting is 4300 RPM.

10. Press the "-" or "+" button to change the maximum RPM.

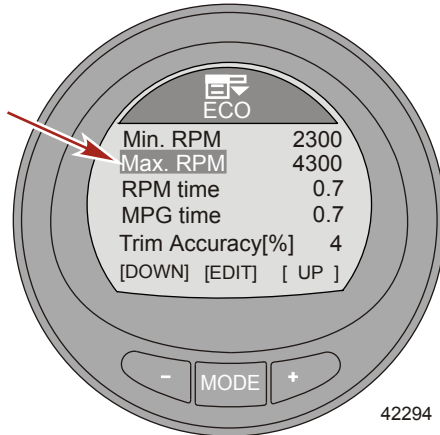

11. Press the "MODE" button to exit the "Max. RPM" edit option.

12. Press the "-" button to highlight the "RPM time" option.

13. Press the "MODE" button to edit the "RPM time" option.

- "RPM time" – Is used to customize the gauge for your boating style. This is how much time (seconds) the RPM must remain consistent at the maximum fuel economy value before the gauge records the RPM and trim targets. The time ranges from 0.0–10.0 seconds. The default setting is 0.7.

# SETTINGS

14. Press the "-" or "+" button to change the "RPM time."

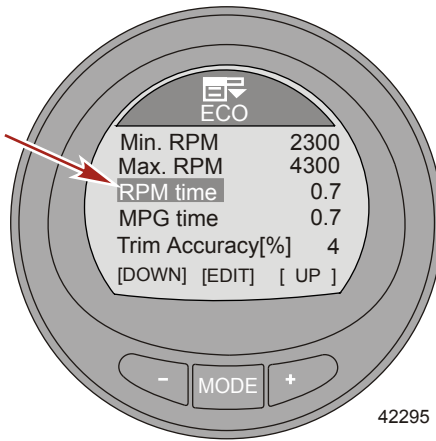

15. Press the "MODE" button to exit the "RPM time" edit option.

16. Press the "-" button to highlight the "MPG time" option.

17. Press the "MODE" button to edit the "MPG time" option.

- "MPG time" – Is used to customize the gauge for your boating style. This is how much time (seconds) the best fuel economy must remain consistent at the maximum value before the gauge records the RPM and trim targets. The time ranges from 0.0–10.0 seconds. The default setting is 0.7.

18. Press the "-" or "+" button to change the "MPG time."

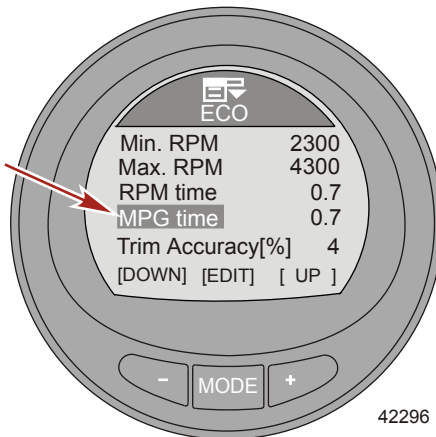

19. Press the "MODE" button to exit the "MPG time" edit option.

20. Press the "-" button to highlight the "Trim Accuracy [%]" option.

21. Press the "MODE" button to edit the "Trim Accuracy [%]" option.

# SETTINGS

- "Trim Accuracy [%]" – Is used to customize the gauge for your boating style. This sets the size of the target window in the ECO screen for the trim position. The percentage ranges from 1–75; the larger the number, the larger the target window. The default setting is 4.
22. Press the "-" or "+" button to change the "Trim Accuracy [%]."

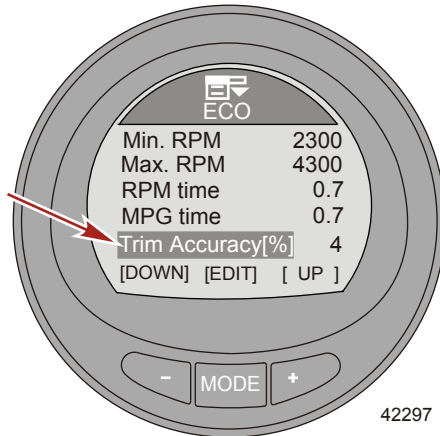

23. Press the "MODE" button to exit the "Trim Accuracy [%]" edit option.
24. Press the "-" button to highlight the "RPM Accuracy [%]" option.
25. Press the "MODE" button to edit the "RPM Accuracy [%]" option.
- "RPM Accuracy [%]" – Is used to customize the gauge for your boating style. This sets the size of the target window in the ECO screen for the RPM. The percentage ranges from 1–75; the larger the number, the larger the target window. The default setting is 4.
26. Press the "-" or "+" button to change the "RPM Accuracy [%]."

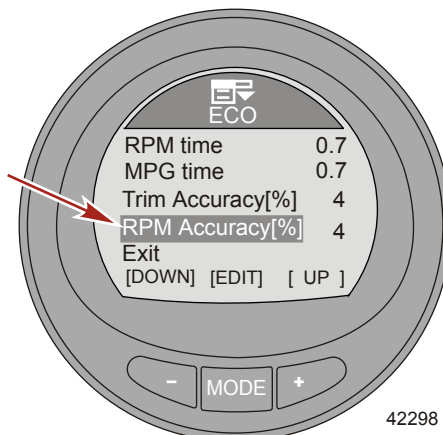

# SETTINGS

27. Press the "MODE" button to exit the "RPM Accuracy [%]" edit option.
28. Press the "-" button to highlight the "Exit" option. Press the "MODE" button to exit the "ECO" menu.

## Setting the System

The "System" menu displays information about the engine, its location, the location of the station, the software version and the level of the gauge. This information cannot be edited.

The gauge can also be reset to the factory default settings. Resetting to factory default will erase all customized menu options. Additionally, the name of the gauge can be edited with up to 14 characters. When the gauge is not connected to an engine, the gauge can be set to "Simulator." This can be used for a visualization simulation of how the gauge screens will appear when installed in a vessel.

1. While in the "Main Menu," press the "-" or "+" button to highlight the "Settings" menu.
2. Press the "MODE" button to enter the "Settings" menu.

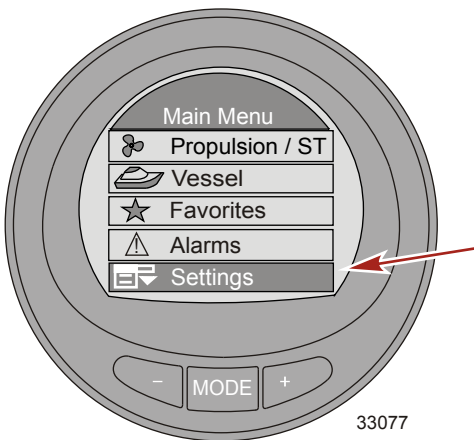

3. Press the "-" button to highlight the "System" menu.

# SETTINGS

4. Press the "MODE" button to edit the "System" menu.

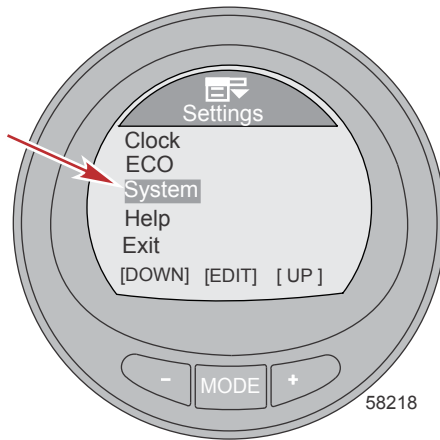

5. Press the "-" button to highlight "Name."
6. Press the "MODE" button to access the "Name" option. The name window will open up on the right side of the gauge.

**NOTE:** The default name is Mercury.

7. Press the "-" or "+" to choose the first letter of the gauge name. To save the letter and move to the next letter selection, press the "MODE" button.

**NOTE:** The gauge name can contain up to 14 characters. There is one empty character and 26 letter characters available. All 14 characters must be selected before exiting the "Name" option.

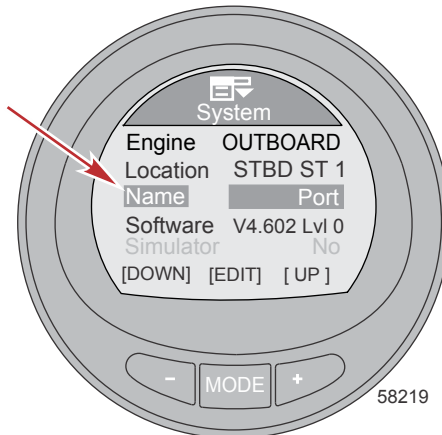

8. After the last character is saved, the name window is not active and the program returns to the "Name" option.

# SETTINGS

9. Press the "-" to highlight the "Simulator" option and press "MODE" to activate the simulation.

**NOTE:** The "Simulator" option is available when the monitor is powered with a 12 volt source for display purpose only. This screen cannot be activated when connected to a power package.

10. Press the "-" to highlight the "Reset All" option.

**IMPORTANT:** Resetting to factory default will erase all customized menu options. Refer to Reset Gauge to the Factory Default Settings.

11. Press the "-" to highlight the "Exit" option and press "MODE" to return to the "Settings" menu.

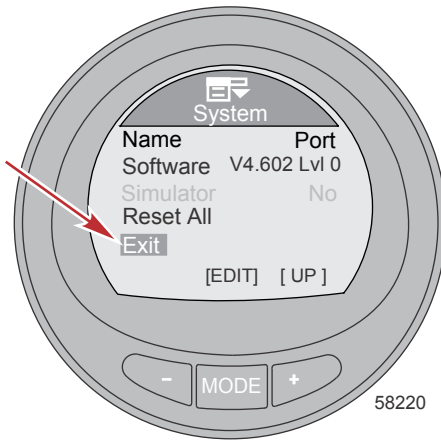

## Reset Gauge to the Factory Default Settings

**IMPORTANT:** Performing a reset will return the gauge to the factory defaults, eliminating any installation and calibrations performed during the set up of the product.

1. While in the "Main Menu," press the "-" or "+" button to highlight the "Settings" menu.

# SETTINGS

2. Press the "MODE" button to enter the "Settings" menu.

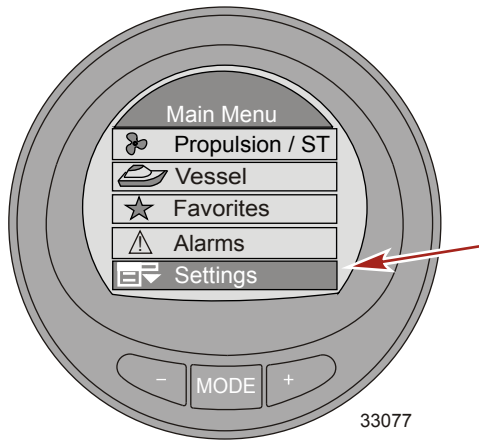

3. Press the "-" button to highlight the "System" menu.
4. Press the "MODE" button to edit the "System" menu.

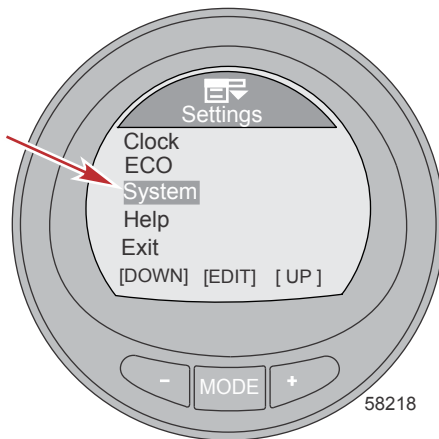

5. Press the "-" button to highlight the "Reset All" option.

# SETTINGS

6. Press the "MODE" button to edit the "Reset All" option.

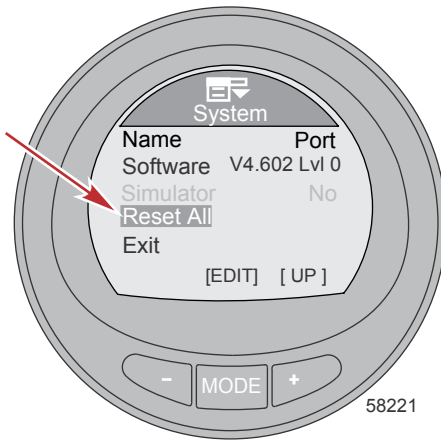

7. Press the "+" to reset the gauge to the factory default settings or press the "MODE" button to quit the reset function.

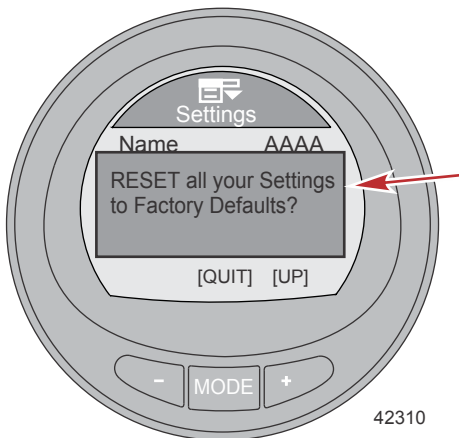



# SETTINGS

8. Press the "-" to confirm resetting the gauge to the factory default settings or press the "MODE" button to quit the reset function.

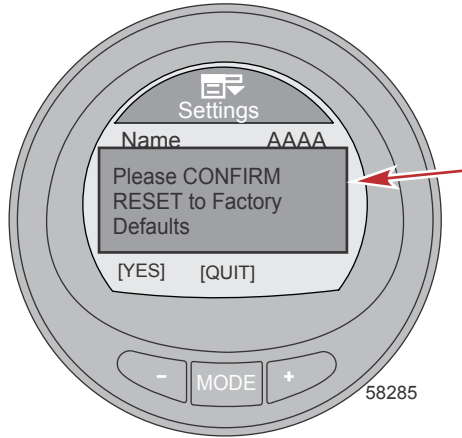

## Help Menu

1. While in the "Main Menu," press the "-" or "+" button to highlight the "Settings" menu.
2. Press the "MODE" button to enter the "Settings" menu.

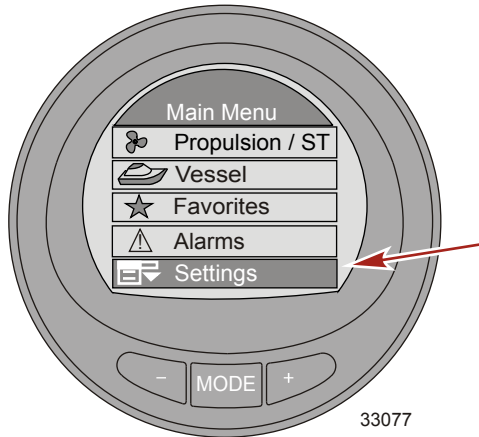

3. Press the "-" button to highlight the "Help" menu.

# SETTINGS

4. Press the "MODE" button to edit the "Help" menu.

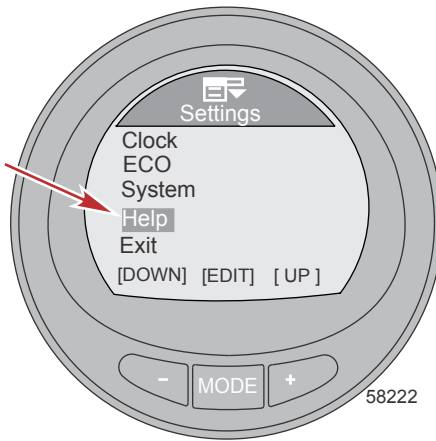

5. Press the "MODE" button to view how to select a screen to be displayed as a favorite.

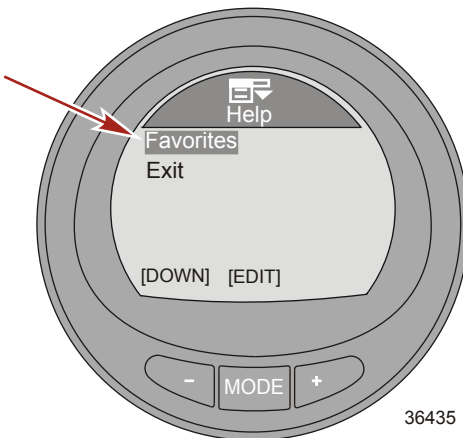

# SETTINGS

6. A window will pop-up stating to hold the "+" and "-" button down when the screen you desire to be part of the "Favorites" is visible on the monitor.

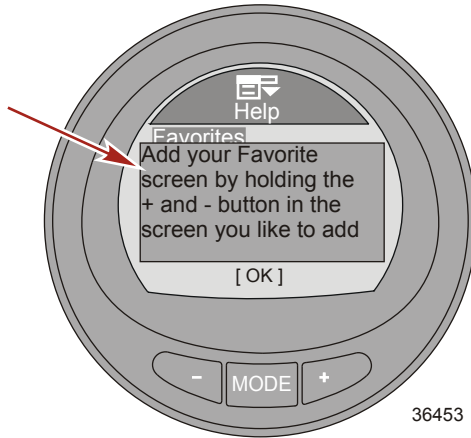

7. Press the "MODE" button to return to the main "Help" menu.
8. Press the "-" button to highlight the "Exit" option and press the "MODE" button to exit the "Help" menu.
9. Press the "-" button to highlight the "Exit" option and press the "MODE" button to exit the "Settings" menu.

# PROPULSION MENU

## Using Propulsion Screens

The "Propulsion" menu screens will display information about the boat propulsion systems. Screens that are available in the "Propulsion" menu may vary according to the engine type, but may include the following:

- Battery voltage
- RPM
- Water pressure
- Coolant temperature
- Oil temperature
- Oil pressure
- Peak speed
- Boost pressure
- Peak RPM
- Trim position
- Tab position
- Troll control

## Available Propulsion Screens

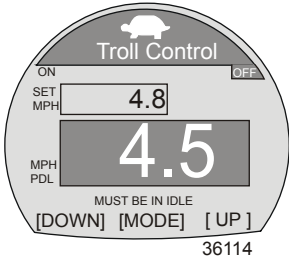
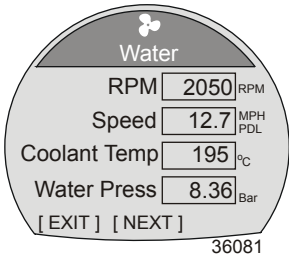
<p>Troll Control</p>	<p>Displays an icon to indicate the troll control is turned on or off. It can be controlled with the vessel speed through the active sensor or with the engine RPM.</p>	
<p>Water</p>	<p>Displays the engine RPM, vessel speed through the active sensor, coolant temperature, and water pressure.</p>	

# PROPULSION MENU

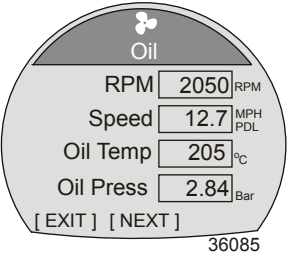
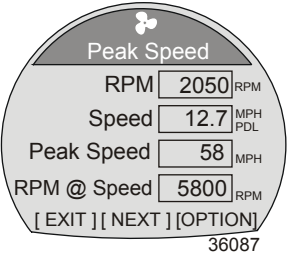
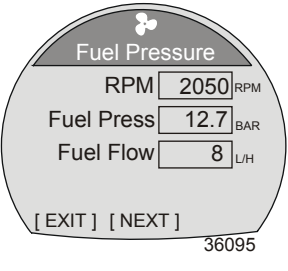
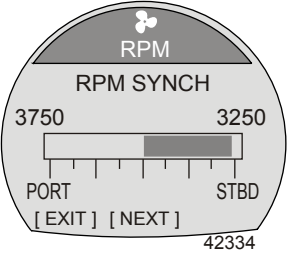
<p>Oil</p>	<p>Displays the engine RPM, vessel speed through the active sensor, oil temperature, and oil pressure.</p>	
<p>Peak Speed</p>	<p>Displays the engine RPM, vessel speed through the active sensor, the peak vessel speed, and what the engine RPM was at that peak vessel speed. The peak values can be reset.</p>	
<p>Fuel Pressure</p>	<p>Displays the engine RPM, fuel pressure, and amount of fuel that is currently used per hour.</p>	
<p>RPM Synch</p>	<p>Displays the engine RPM and color band indicating to increase or decrease the RPM to synchronize the engines.</p>	

# PROPULSION MENU

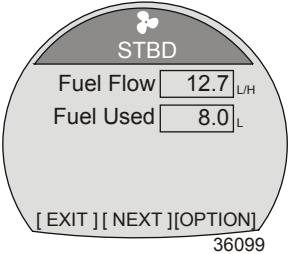
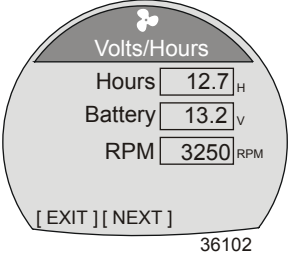
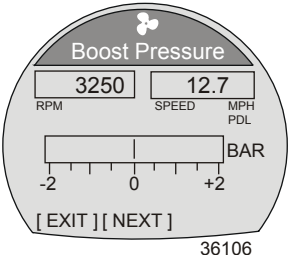
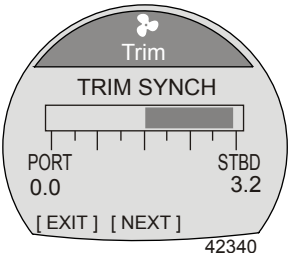
<p>Engine Location Fuel Use</p>	<p>Displays the engine location the gauge is connected to, the amount of fuel that is currently used per hour, and the amount of fuel that has been used. The amount of fuel used can be reset.            STBD (starboard engine)            PORT (port engine)            CNTR (center engine)            STB2 (starboard center)            PRT2 (port center)</p>	 <p>The gauge displays 'STBD' at the top. Below it, 'Fuel Flow' is shown as 12.7 L/H and 'Fuel Used' as 8.0 L. At the bottom, there are navigation options: [EXIT] [NEXT] [OPTION] and the number 36099.</p>
<p>Volts/ Hours</p>	<p>Displays the total hours the engine has run, the battery current state of charge, and the engine RPM.</p>	 <p>The gauge displays 'Volts/Hours' at the top. Below it, 'Hours' is 12.7 H, 'Battery' is 13.2 V, and 'RPM' is 3250 RPM. At the bottom, there are navigation options: [EXIT] [NEXT] and the number 36102.</p>
<p>Boost Pressure</p>	<p>Displays the engine RPM, the vessel speed through the active sensor, and the amount of manifold pressure.</p>	 <p>The gauge displays 'Boost Pressure' at the top. Below it, 'RPM' is 3250 and 'SPEED MPH PDL' is 12.7. A pressure scale in BAR ranges from -2 to +2. At the bottom, there are navigation options: [EXIT] [NEXT] and the number 36106.</p>
<p>Trim Synch (Dual Engine)</p>	<p>Displays a color band indicating to increase or decrease the trim to synchronize the engines trim location.</p>	 <p>The gauge displays 'Trim' at the top and 'TRIM SYNCH' below it. A horizontal bar indicates the trim level between 'PORT 0.0' and 'STBD 3.2'. At the bottom, there are navigation options: [EXIT] [NEXT] and the number 42340.</p>

# PROPULSION MENU

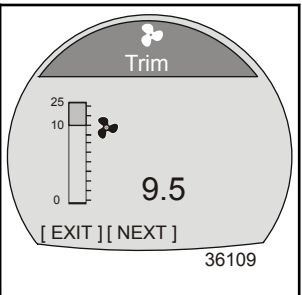
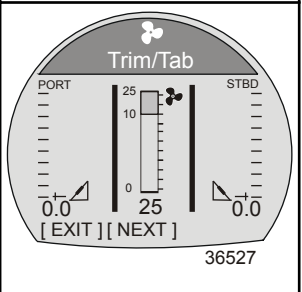
<p>Trim</p>	<p>Displays the position of the trim with a moving propeller icon and displays the trim position number relative to the propeller icon.</p>	 <p>36109</p>
<p>Trim/Tab</p>	<p>Displays the position of the port and starboard tabs with a moving tab icon and the trim position with a moving propeller icon. A number relative to the position of the icons is also displayed in the lower portion of the screen.</p>	 <p>36527</p>

## Troll Control Screen

The "Troll Control" screen displays an icon to indicate the troll control is turned on or off, the engine RPM, or the vessel speed. Troll control can be controlled by the vessel speed or the engine RPM.

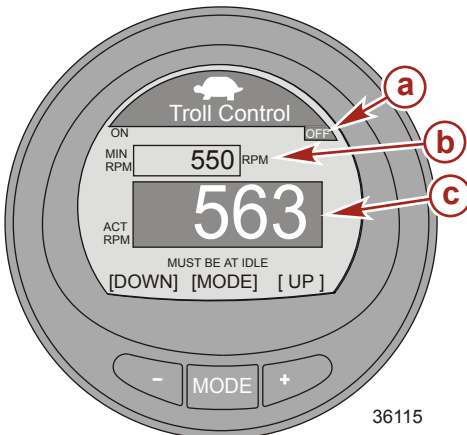

- a** - Icon indicating troll control is turned off
- b** - Set RPM
- c** - Actual engine RPM

## TURNING TROLL CONTROL ON AND OFF

1. Ensure the engine is running and the remote control is in gear at idle.

# PROPULSION MENU

- To turn the troll control on, press the "-" and "+" buttons at the same time. The troll control "ON" icon will be highlighted and the information below the RPM will change to "+/- TO DISENGAGE."

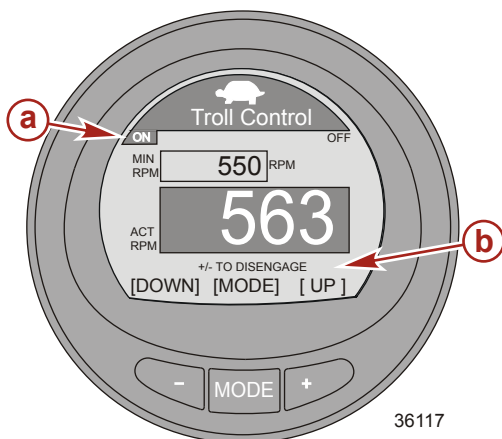

- a - Troll control "ON" icon
- b - "+/- TO DISENGAGE"

- Press the "-" or "+" button to decrease or increase the engine RPM.

**NOTE:** The minimum RPM and the maximum RPM will depend on the power package application.

- To turn the troll control off, press the "-" and "+" buttons at the same time, or move the remote control handle into neutral. The troll control "OFF" icon will be highlighted and the information below the RPM will change to "+/- TO ENGAGE."

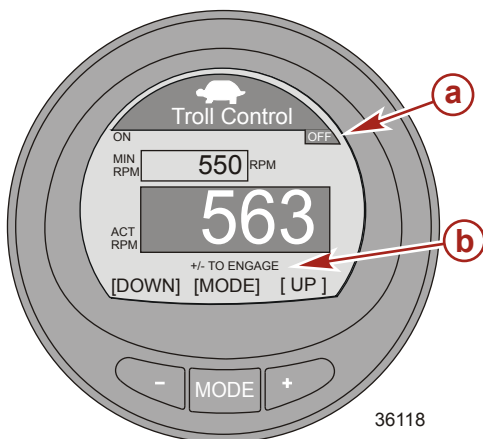

- a - Troll control "OFF" icon
- b - "+/- TO ENGAGE"



# PROPULSION MENU

## CHANGING THE TROLL CONTROL MODE OF CONTROL

The troll control function can be controlled with the engine RPM or the vessel speed. To use the vessel speed to control the troll function, a paddle wheel must be installed. Using the engine RPM to control the troll function will cause the vessel speed to vary based on the conditions the vessel encounters: wind, waves, or current. Using the vessel speed to control the troll function will cause the engine RPM to fluctuate more, based on the conditions the vessel encounters: wind, waves, or current. Changing the troll control mode can be done when the troll control is turned on or off.

1. While the troll control screen is visible, press and hold the "MODE" button until the screen changes mode.

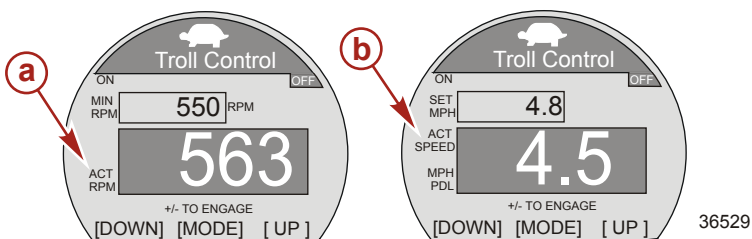

- a - RPM mode
- b - Speed mode

2. Press the "-" or "+" button to change the speed. The engine RPM will react to the selected speed when the troll control is engaged.
3. To change back to the RPM mode, press and hold the "MODE" button until the screen changes from speed mode to the RPM mode.
4. If there is no paddle wheel installed on the vessel, the speed mode of control will show text below the "ACT SPEED" window indicating a paddle wheel is required ("PADDLE REQUIRED").

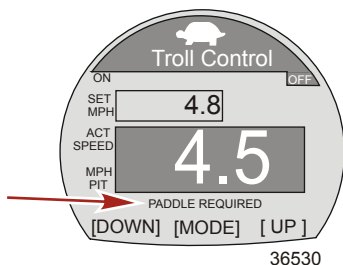

# PROPULSION MENU

## Water Screen

The "Water" screen displays the engine RPM, vessel speed through the active sensor, coolant temperature, and water pressure.

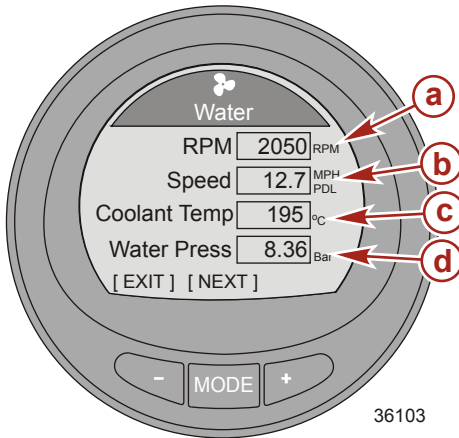

- a - RPM
- b - Vessel speed
- c - Coolant temperature
- d - Water pressure

## Oil Screen

The "Oil" screen displays the engine RPM, vessel speed through the active sensor, oil temperature, and oil pressure.

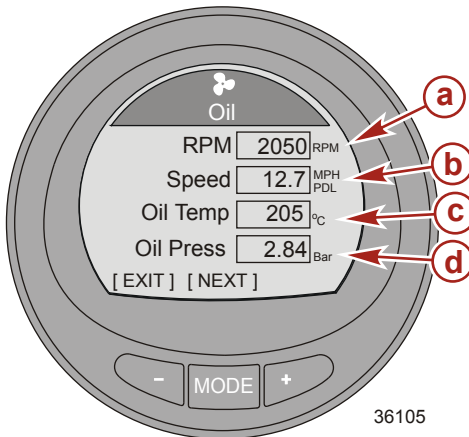

- a - RPM
- b - Vessel speed
- c - Oil temperature
- d - Oil pressure

# PROPULSION MENU

## Peak Speed Screen

The "Peak Speed" screen displays the engine RPM, vessel speed through the active sensor, the peak vessel speed, and what the engine RPM was at that peak vessel speed. The peak values information will automatically update when the recorded values are exceeded.

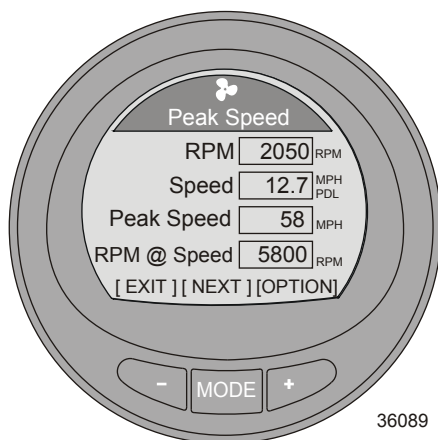

## RESET PEAK VALUES

The peak values can be reset to record new information.

1. Press the "+" button to open the option to reset the peak values.
2. Press the "-" ("YES") or "+" ("NO") to reset the peak values. The screen will return to the "Peak Speed" screen.

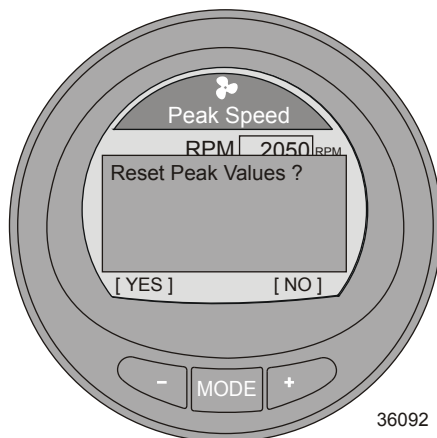

# PROPULSION MENU

## Fuel Pressure Screen

The "Fuel Pressure" screen displays the engine RPM, fuel pressure, and amount of fuel that is currently used per hour. The fuel flow is calculated by the PCM/ECM.

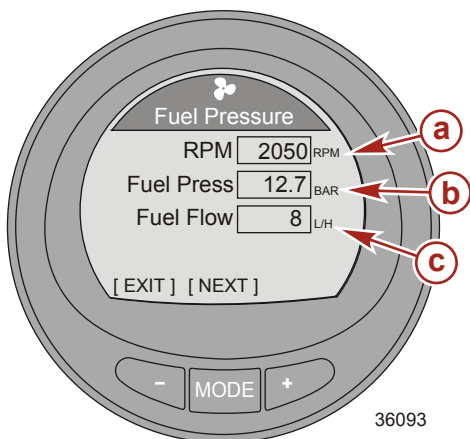

- a - RPM
- b - Fuel pressure
- c - Fuel flow

36093

## RPM Synchronize Screen

The "RPM SYNCH" screen displays the engine RPM and a color band that expands under the engine with the lower RPM. The color band will decrease in size as the engine RPM's near synchronization.

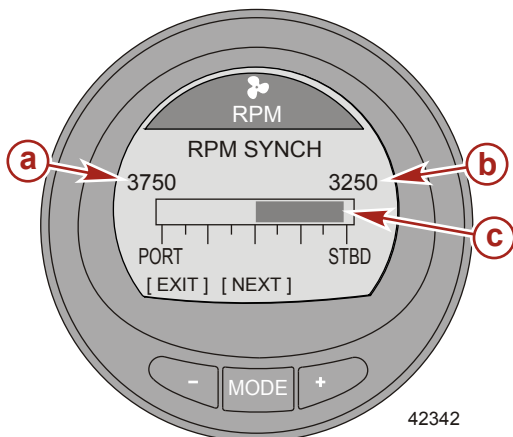

- a - Port engine RPM
- b - Starboard engine RPM
- c - Color band indicating starboard engine RPM is low

42342

# PROPULSION MENU

## Engine Location Fuel Use

The engine location fuel use screen shows the engine location the gauge is connected to in the upper part of the screen, the amount of fuel that is currently used per hour, and the amount of fuel that has been used for that particular engine. The amount of fuel used can be reset.

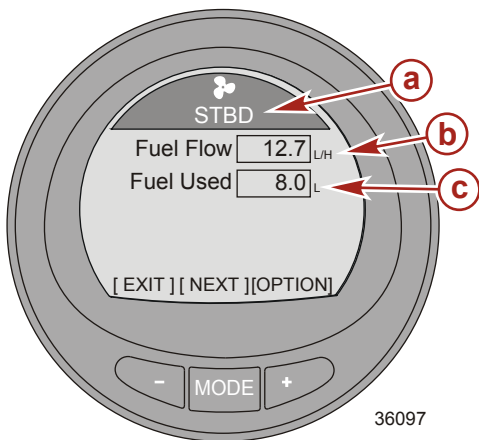

- a - Engine location gauge is connected to
- b - Fuel flow
- c - Fuel used

## FUEL USED RESET

1. Press the "+" button to open the "Fuel Used" reset option.
2. Press the "-" ("YES") button to reset the fuel used, or the "+" ("NO") button to return to the fuel use per engine location screen.

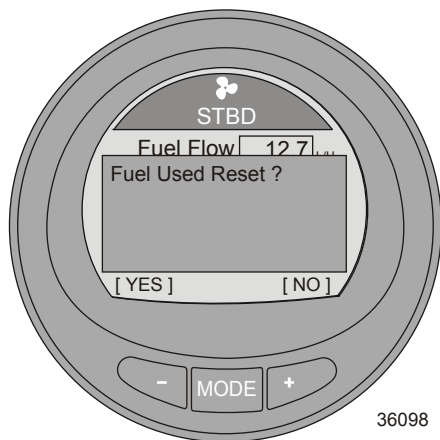

# PROPULSION MENU

## Volts/Hours Screen

The "Volts/Hours" screen displays the total hours the engine has run, the battery current state of charge, and the engine RPM.

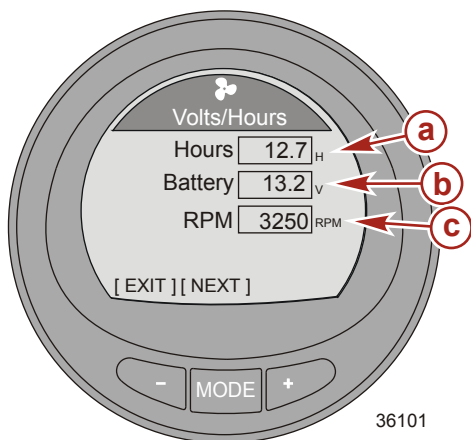

- a** - Total engine hours
- b** - Battery state of charge
- c** - RPM

## Boost Pressure Screen

The "Boost Pressure" screen displays the engine RPM, the vessel speed through the active sensor, and the amount of manifold pressure.

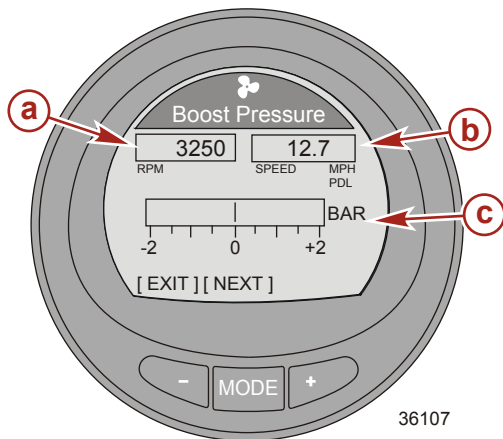

- a** - RPM
- b** - Vessel speed
- c** - Manifold pressure

# PROPULSION MENU

## Trim Synchronize Screen

The "Trim Synch" screen displays a color band indicating to increase or decrease the trim to synchronize the engines trim location. The numbers are a point of reference, relating to the position of the trim outside of the synchronization.

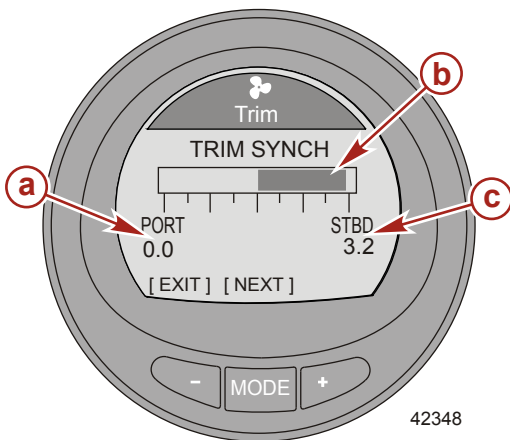

- a** - Port engine trim point of reference
- b** - Color band
- c** - Starboard engine trim point of reference

## Trim Screen

The "Trim" screen displays the position of the trim with a moving propeller icon and displays the trim position number relative to the propeller icon.

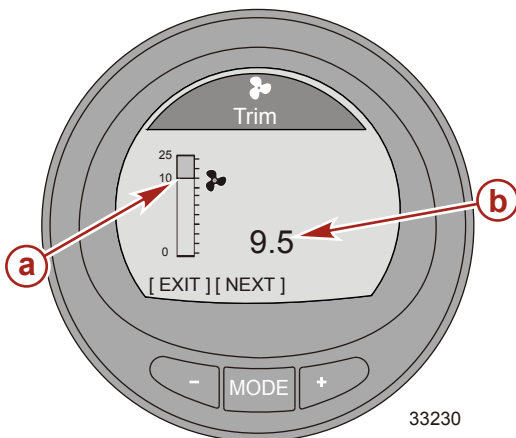

- a** - Trim indicator
- b** - Number indicating the relative position

# PROPULSION MENU

## Trim/Tab Screen

The "Trim/Tab" screen displays the position of the port and starboard tabs with a moving icon that represents the relative position of the tabs. A number below the tab display will indicate the relative position of the tab. The center of the display will show the position of the trim with a moving icon that represents the relative position of the trim. A number below the trim display will indicate the relative position of the trim.

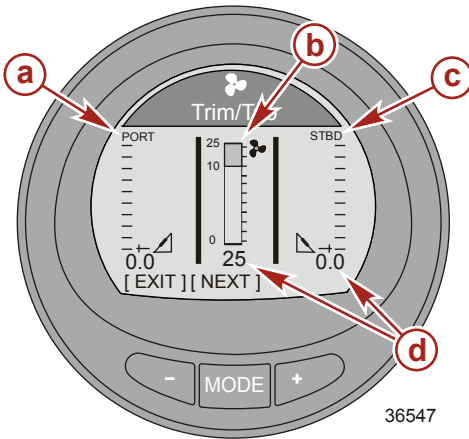

- a** - Port tab indicator
- b** - Trim indicator
- c** - Starboard tab indicator
- d** - Number indicating the relative position

36547



# VESSEL MENU

## Using the Vessel Screens

The vessel menu screens will display information concerning the vessel and associated systems. Screens that are available in the vessel menu may vary according to the engine type, but may include the following:

- Economy (ECO)
- Trip data
- Range
- Trim
- Fuel tank1
- Tank 2
- Tabs
- GPS information
- Waypoint information
- Steering position
- Depth

## Available Vessel Screens

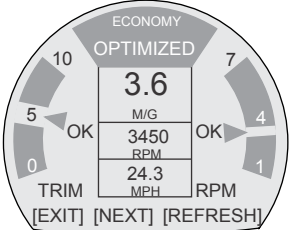
Economy (ECO)	<p>The software for the economy screen monitors the engine sensors and looks for the best fuel economy number while running the boat. When the software recognizes an improvement in the fuel economy, the gauge records what the trim and engine RPM values are at that time. This calculation happens whether the ECO screen is visible or not. When the software has recorded the RPM and trim values, it will guide the operator with arrows, to where that optimum running speed and trim setting was. The ECO screen does not need any calibration, although there are settings to customize the gauge for your boating style. The economy screen optimized values can be reset.</p>	 <p>42352</p>
---------------	--	---

# VESSEL MENU

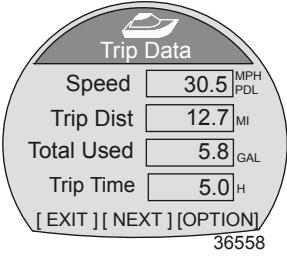
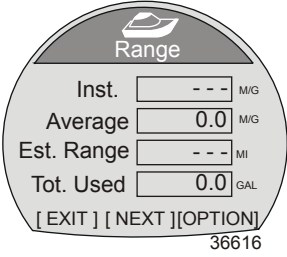
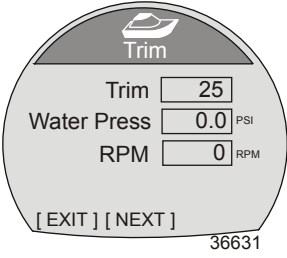
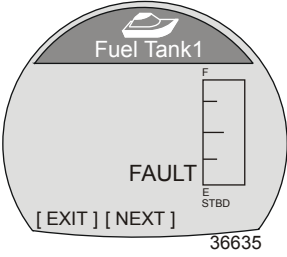
<p>Trip Data</p>	<p>Displays the vessel speed through the available sensor, the current trip distance, the total amount of fuel used, and the current amount of time during the trip. The distance, fuel used, and time can be reset.</p>	 <p>36558</p>
<p>Range</p>	<p>Displays the current amount of fuel economy, the average amount of fuel used, the estimated distance the vessel can travel based on the current usage, and the total amount of fuel used. The average fuel used and the total amount used can be reset.</p>	 <p>36616</p>
<p>Trim</p>	<p>Displays a number relating to the position of the trim system, the engine water pressure, and the engine RPM.</p>	 <p>36631</p>
<p>Fuel Tank1</p>	<p>Displays the level of the fuel tank, the location of the fuel tank, and will display "FAULT" when there is a problem with the fuel tank. It can also be selected as not installed ("Not inst"). When selected as not installed, the "Fuel Tank 1" screen will not be accessible.</p>	 <p>36635</p>

# VESSEL MENU

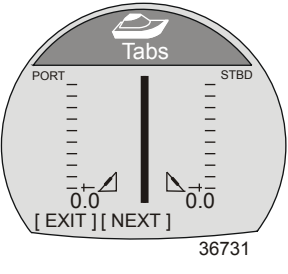
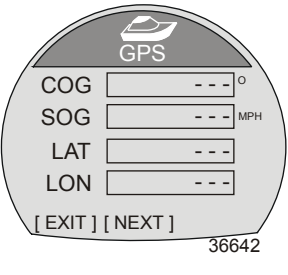
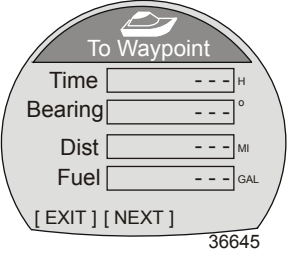
<p>Tank 2</p>	<p>Tank 2 can be selected as not installed, fuel, water, or waste when connected to a 4-Stroke engine. When selected as fuel, the level can be calibrated with a default setting, or by adding fuel. When selected as water or waste, the level is calibrated to the default setting.</p>	 <p>Water Tank</p> <p>0 %</p> <p>[EXIT] [NEXT]</p> <p>36637</p>
<p>Tabs</p>	<p>Displays the position of the tabs with numbers and a bar graph for each tab.</p>	 <p>Tabs</p> <p>PORT STBD</p> <p>0.0 0.0</p> <p>[EXIT] [NEXT]</p> <p>36731</p>
<p>GPS</p>	<p>Displays the course over ground ("COG"), speed over ground ("SOG"), latitude position ("LAT"), and longitude position ("LON"). A GPS must be installed for this option to display information.</p>	 <p>GPS</p> <p>COG --- °</p> <p>SOG --- MPH</p> <p>LAT ---</p> <p>LON ---</p> <p>[EXIT] [NEXT]</p> <p>36642</p>
<p>To Waypoint</p>	<p>Displays the amount of time to the waypoint, the compass bearing towards the waypoint, the distance to the waypoint, and the amount of fuel required to the waypoint. A GPS must be installed with a SmartCraft puck for this option to display information.</p>	 <p>To Waypoint</p> <p>Time --- H</p> <p>Bearing --- °</p> <p>Dist --- MI</p> <p>Fuel --- GAL</p> <p>[EXIT] [NEXT]</p> <p>36645</p>

# VESSEL MENU

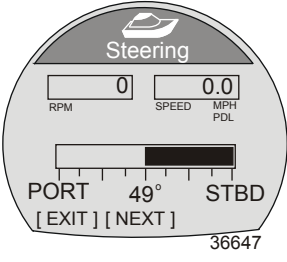
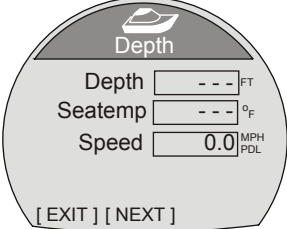
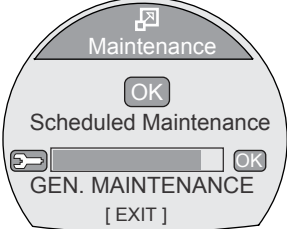
<p>Steering</p>	<p>Displays the engine RPM, the vessel speed, a bar graph indicating the direction of the steering ("PORT" or "STBD"), and a number displayed to indicate the relative position of the steering. A steering position sensor must be installed for this screen to display the steering direction and relative position.</p>	 <p>36647</p>
<p>Depth</p>	<p>Displays the depth of the water, the temperature of the water, and the speed of the vessel through the active sensor.</p>	 <p>36650</p>
<p>Maintenance</p>	<p>Some 4-Stroke power package models can estimate the amount of time the engine has run since the last scheduled maintenance. Normal scheduled maintenance for the engine is every 100 hours. The maintenance screen shows a bar graph approximating the amount of time remaining before a scheduled maintenance is required. When the maintenance screen is reset, the bar graph will change to 100 hours before the next scheduled maintenance. The maintenance screen must be turned on for this screen to be displayed. Your owner's manual maintenance schedule should be followed regardless of what the gauge displays. To turn this feature on, refer to <b>Settings—Turning the Screens On</b>.</p>	 <p>50377</p>

# VESSEL MENU

## Economy (ECO) Screen

The economy screen monitors the engine sensors and looks for the best fuel economy number while the vessel is under way. When the software recognizes an improvement in the fuel economy, the gauge records what the trim and engine RPM values are at that time. This calculation happens whether the ECO screen is visible or not. When the software has recorded the RPM and trim values, it will guide the operator with arrows to where that optimum running speed and trim setting was. **The ECO screen does not need any calibration**, although there are settings to customize the gauge for your boating style. The default settings are within acceptable parameters for most vessel applications.

When the economy screen is "OPTIMIZED," the backlighting of the screen will turn to green. While "OPTIMIZED," the trim and RPM arrows will be aligned with the economy target windows. When either the trim or RPM arrows are outside the target window, the arrows will become hollow and the backlighting will turn to yellow. These color changes are difficult to identify in the sunlight. The target windows can be made smaller or larger. The menu path to change the target window size is: "Settings," > "ECO," > "Trim Accuracy [%]" for trim, or "RPM Accuracy [%]" for RPM. The default number of 4 is generally a good setting for most vessel configurations. The higher the number, the larger the target window.

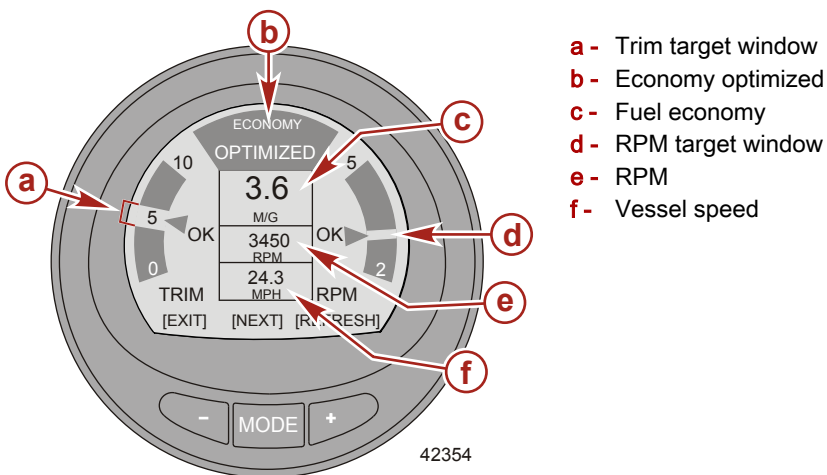

# VESSEL MENU

- If the software has recorded an economy value that is better than where you are currently, the screen will show "NOT OPTIMIZED" at the top of the screen and the backlighting will turn to the color yellow. This color change is difficult to identify in the sunlight. The trim position arrow will become hollow, a guide arrow will appear indicating the trim position must be changed either up or down, and the recorded target window will appear in a new location. Pressing the refresh button "+" ("REFRESH") at any time while the economy screen is visible will restart the economy calculations.

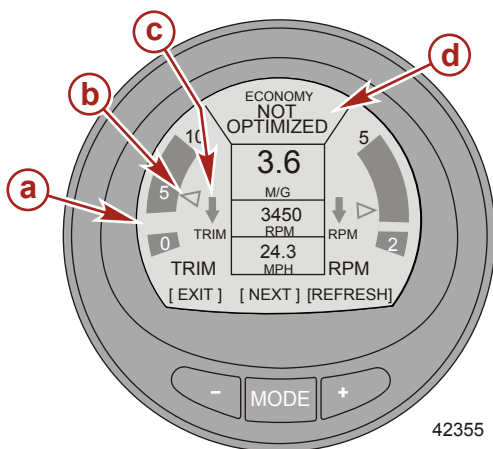

- a** - New recorded target window
- b** - Hollow arrow
- c** - Guide arrow indicating direction change
- d** - Screen showing "NOT OPTIMIZED"

42355

- When the trim target is achieved, the trim position arrow will no longer be hollow, and "OK" will replace the guide arrow.

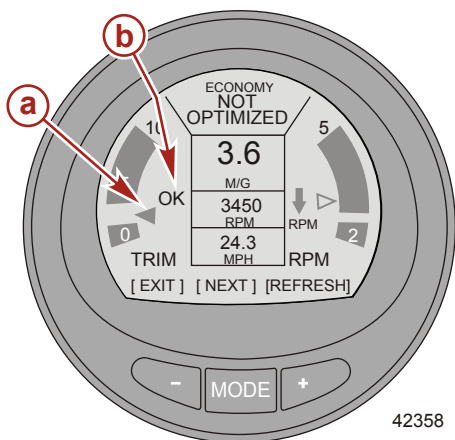

- a** - Trim position arrow not hollow
- b** - "OK" replaces guide arrow

42358

# VESSEL MENU

- The RPM position arrow will become hollow, a guide arrow will appear indicating the RPM must be raised or lowered, and the recorded target window will appear in a new location.

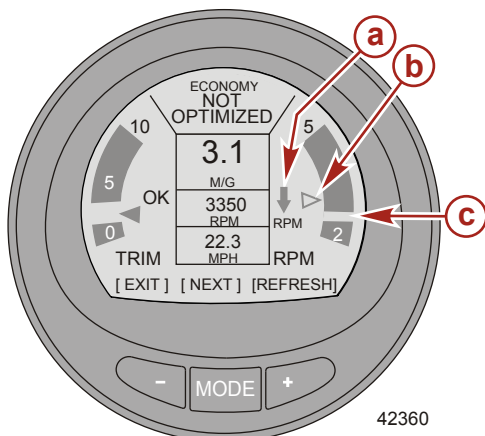

- a** - Guide arrow indicating direction change
- b** - Hollow arrow
- c** - New recorded target window

- When the RPM target is achieved, the RPM arrow will no longer be hollow, and "OK" will replace the guide arrow. The screen will change color from yellow to green indicating the engine is at the optimized running RPM and trim position. The color change is difficult to identify in the sunlight.

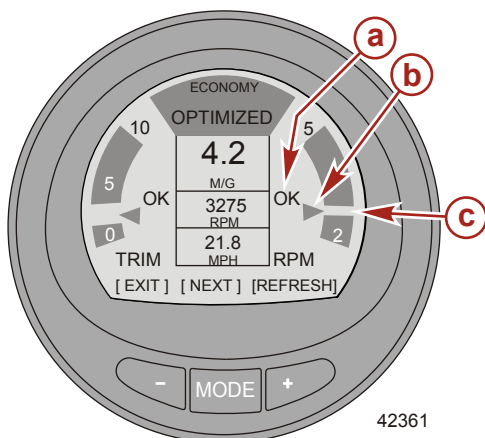

- a** - "OK" replaces guide arrow
- b** - Trim position arrow not hollow
- c** - New recorded target window

# VESSEL MENU

- If the RPM exceeds the maximum selected RPM in the "Settings" menu, the screen will change color and advised to decrease the RPM below the selected RPM.

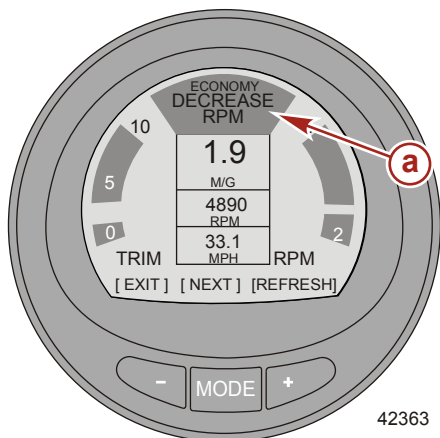

a - Decrease RPM screen

- To change the maximum selected RPM, go to the economy screen in the "Settings" menu. The menu path is: "Settings," > "ECO," > "Max RPM." The default setting is 4300.

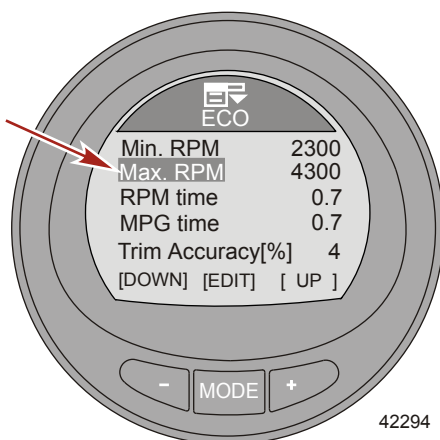



# VESSEL MENU

- If the RPM drops below the minimum selected RPM in the "Settings" menu, the screen will change color and advised to increase the RPM above the selected RPM.

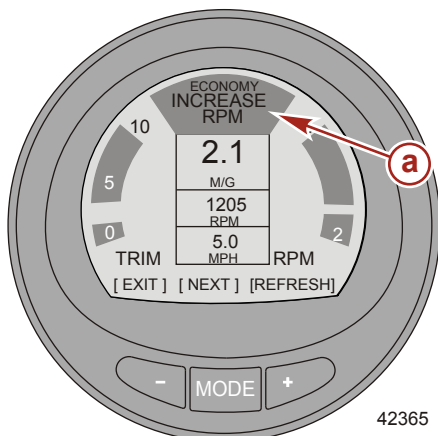

a - Increase RPM screen

- To change the minimum selected RPM, go to the economy screen in the "Settings" menu. The menu path is: "Settings," > "ECO," > "Min RPM." The default setting is 2300 RPM.

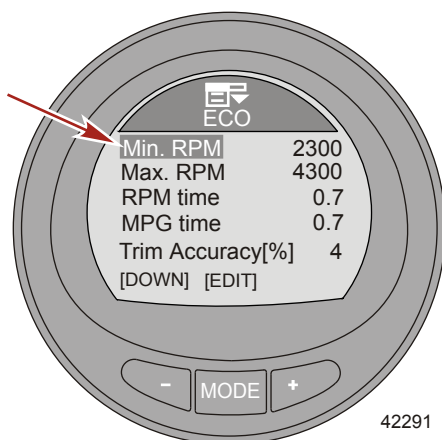

42291

# VESSEL MENU

## ECONOMY RESET

- To recalculate the RPM and trim targets, press the "REFRESH" ("+") button. The gauge software will calculate the targets for the maximum economy.

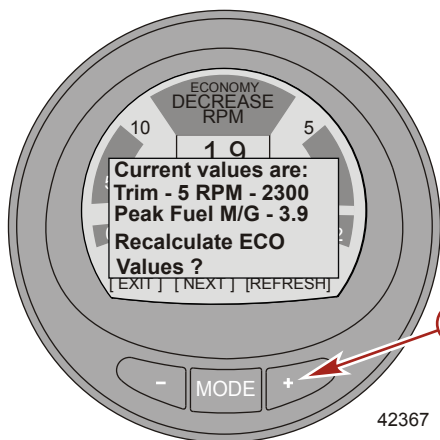

a - "REFRESH" ("+") button

## Trip Data Screen

The "Trip Data" screen displays the current vessel speed. This data is based on which sensor is active; pitot sensor, paddle wheel, or GPS. The type of speed sensor is displayed on the right side of the "Speed" information window. When the transition speed is reached, the new active speed sensor will then be displayed.

The trip distance ("Trip Dist") will display how far the vessel has traveled. The trip distance can be reset.

The total fuel used ("Total Used") is the total of all the engines running on the vessel, displaying how much fuel has been used down to a tenth of the unit. The total fuel used can be reset.

# VESSEL MENU

The current amount of time the trip has taken ("Trip Time") will be displayed in tenths of an hour. The trip time can be reset.

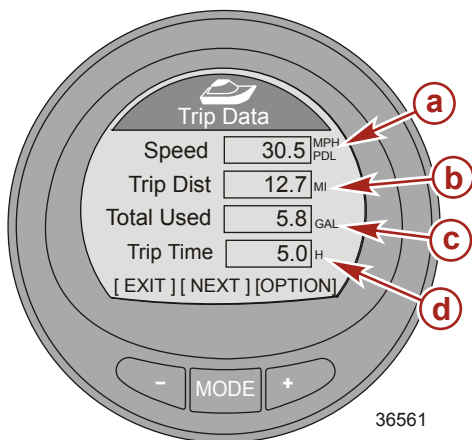

- a - Paddle wheel speed
- b - Trip distance
- c - Total fuel used
- d - Trip time

## RESETTING THE TRIP DATA INFORMATION

1. While the "Trip Data" option screen is visible, press the "+" button to open the reset option.
2. A pop-up window will appear asking to reset the trip distance ("Trip Distance Reset?").
3. Press the "-" button for "Yes," or press the "+" button for "No."

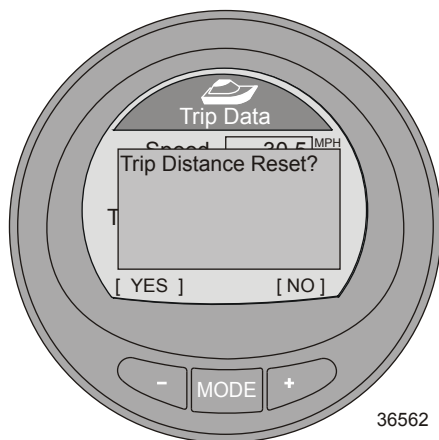

4. The next pop-up window will appear asking to reset the trip time ("Trip Time Reset?").

# VESSEL MENU

5. Press the "-" button for "Yes," or press the "+" button for "No."

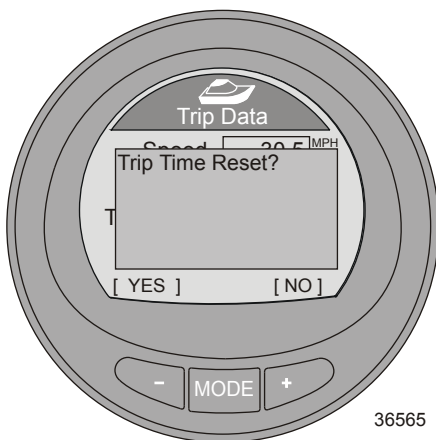

6. The next pop-up window will appear asking to reset the amount of fuel used ("Fuel Used Reset?").
7. Press the "-" button for "Yes," or press the "+" button for "No".

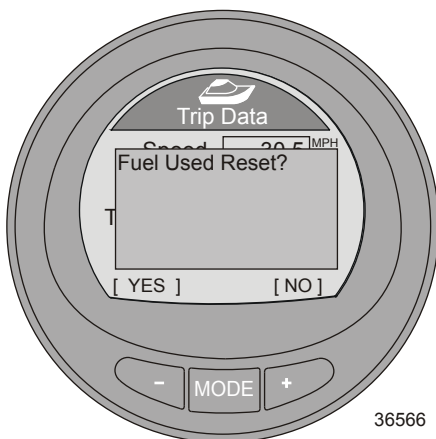

8. Press the "-" button to return to the "Main Menu," or press the "MODE" button to go to the next screen.

# VESSEL MENU

## Range Screen

The "Range" screen displays the current amount of fuel economy, the average amount of fuel used, the estimated distance the vessel can travel based on the current usage, and the total amount of fuel used. The average fuel used and the total amount used can be reset.

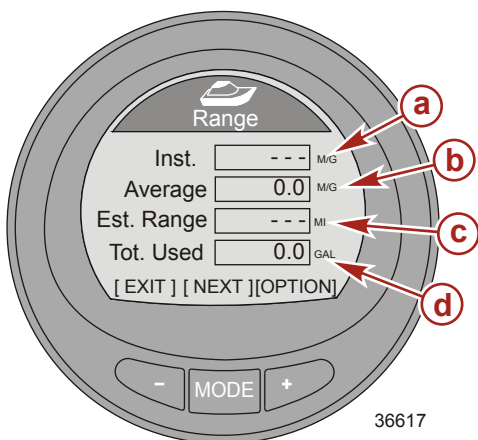

- a - Current fuel economy
- b - Average fuel used
- c - Estimated distance
- d - Total fuel used

## RESET RANGE SCREEN OPTIONS

1. To reset the average fuel used, press the "+" button to access the reset option.
2. A pop-up screen will appear asking if the average fuel economy should be reset ("Average Fuel Eco Reset?").
3. Press the "-" button for "Yes," or press the "+" button for "No".

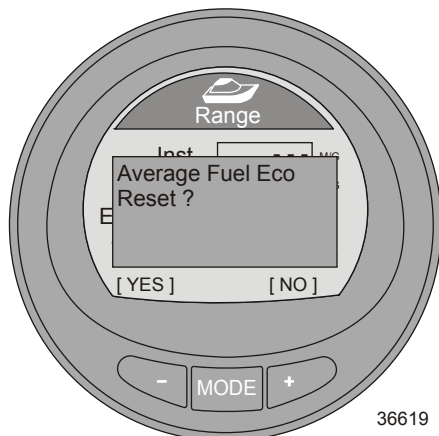

4. After pressing either button, a pop-up window appears asking if the total fuel used should be reset ("Fuel Used Reset?").

# VESSEL MENU

5. Press the "-" button for "Yes," or press the "+" button for "No."

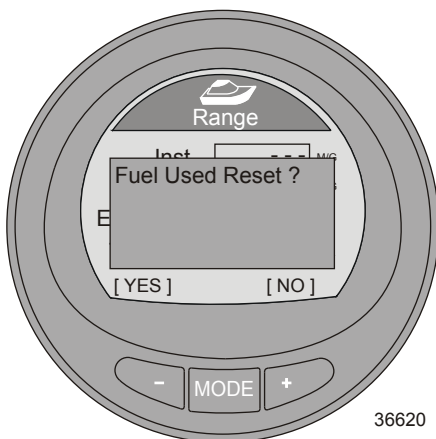

6. Press the "-" button to return to the "Main Menu," or press the "MODE" button to go to the next screen.

## Trim Screen

The "Trim" screen displays a number relating to the position of the trim system, the engine water pressure, and the engine RPM.

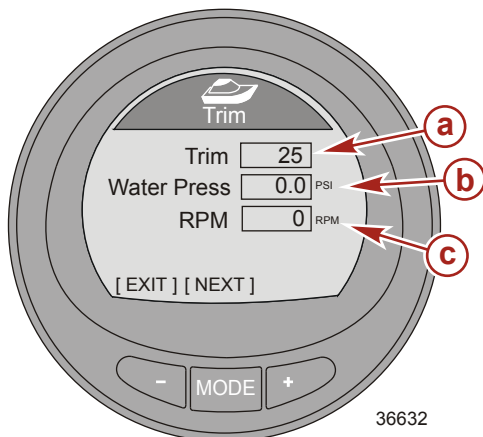

- a** - Trim position number
- b** - Water pressure
- c** - Engine RPM

Press the "-" button to return to the "Main Menu," or press the "MODE" button to go to the next screen.

# VESSEL MENU

## Tanks

### FUEL TANK 1

The "Fuel Tank 1" screen displays the level of the fuel tank, the location of the fuel tank, and will display "FAULT" when there is a problem with the fuel tank. It can also be selected as not installed ("Not inst"). When selected as not installed, the "Fuel Tank 1" screen will not be accessible.

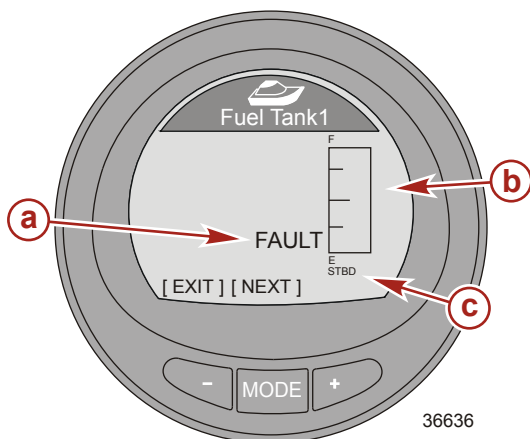

- a** - Fuel tank fault ("FAULT")
- b** - Fuel level
- c** - Tank location

36636

### TANK 2

"Tank 2" can be selected as not installed ("Not inst"), fuel, water, or waste when connected to a four-stroke engine. When selected as fuel, the level can be calibrated with a default setting, or by adding fuel. When selected as water or waste, the level is automatically calibrated to the default setting.

When the gauge is installed on a vessel with a two-stroke engine, "Tank 2" will automatically default to oil.

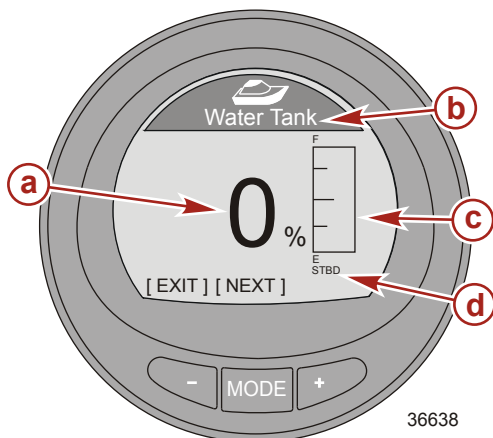

- a** - Tank level percentage
- b** - Tank type
- c** - Tank level
- d** - Tank location

36638

# VESSEL MENU

Press the "-" button to return to the "Main Menu," or press the "MODE" button to go to the next screen.

## Tabs Screen

The "Tabs" screen displays the port tab and starboard tab position with a bar graph and numbers.

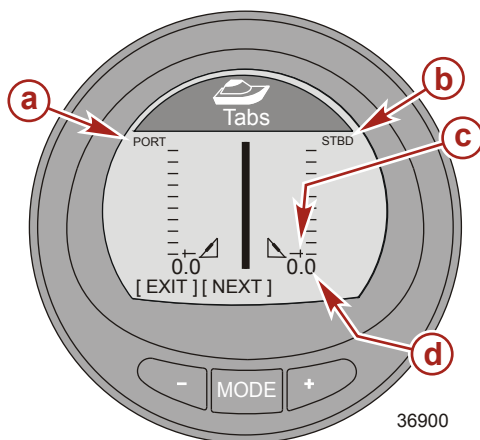

- a** - Port tab bar graph
- b** - Starboard tab bar graph
- c** - Bar graph pointer
- d** - Tab position number

Press the "-" button to return to the "Main Menu," or press the "MODE" button to go to the next screen.

## GPS Screen

The "GPS" screen displays the course over ground ("COG"), speed over ground ("SOG"), latitude position ("LAT"), and longitude position ("LON"). A GPS must be installed for this option to display information.

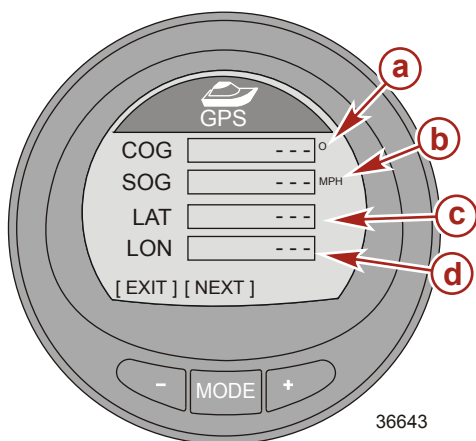

- a** - Course over ground ("COG")
- b** - Speed over ground ("SOG")
- c** - Latitude position ("LAT")
- d** - Longitude position ("LON")

Press the "-" button to return to the "Main Menu," or press the "MODE" button to go to the next screen.



# VESSEL MENU

## To Waypoint Screen

The "To Waypoint" screen displays the amount of time required to reach the waypoint, the compass bearing towards the waypoint, the distance to the waypoint, and the amount of fuel required to the waypoint. A GPS and chart plotter or a device capable of generating waypoints must be installed for this option to display information.

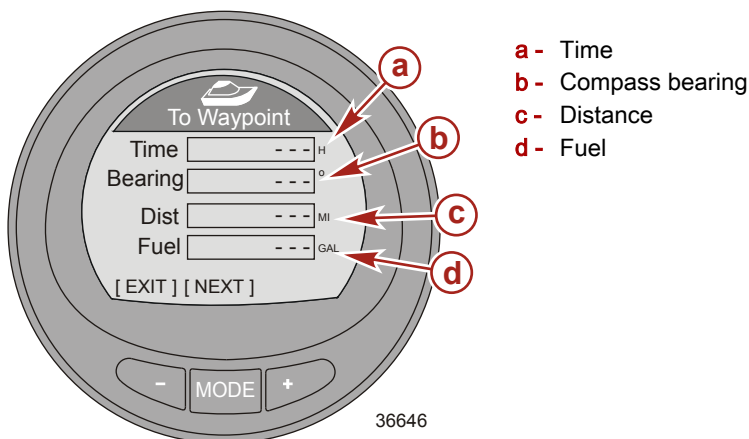

Press the "-" button to return to the "Main Menu," or press the "MODE" button to go to the next screen.

## Steering Screen

The "Steering" screen displays the engine RPM, the vessel speed, a bar graph indicating the direction of the steering ("PORT" or "STBD"), and a number displayed to indicate the relative position of the steering. A steering position sensor must be installed for this screen to display the steering direction and relative position.

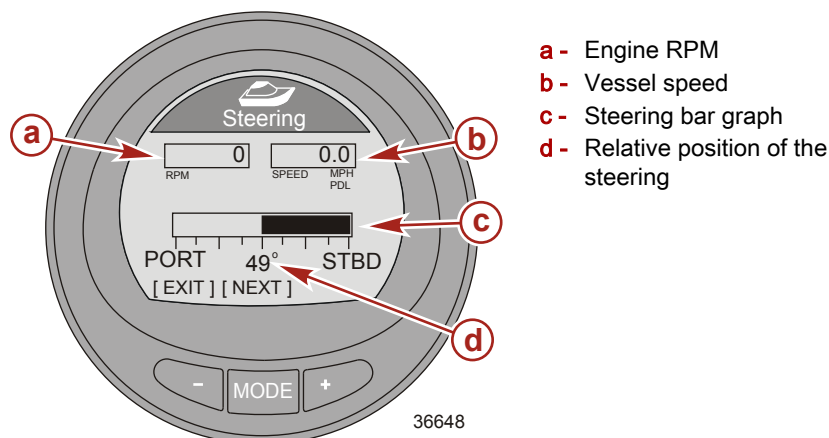

# VESSEL MENU

Press the "-" button to return to the "Main Menu," or press the "MODE" button to go to the next screen.

## Depth Screen

The "Depth" screen displays the depth of the water, the temperature of the water, and the speed of the vessel through the available sensor. The actual depth may be different from what is displayed and is dependent on the amount of offset that is programmed in the "Settings" menu.

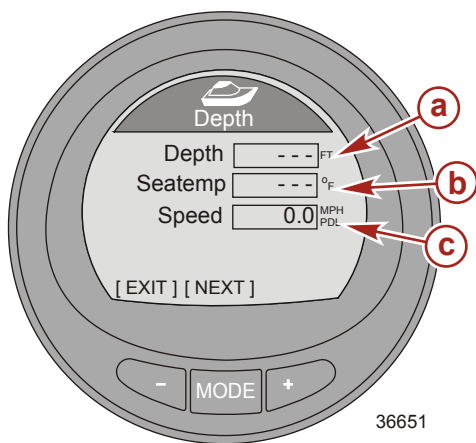

- a** - Depth
- b** - Water temperature
- c** - Vessel speed

36651

Press the "-" button to return to the "Main Menu," or press the "MODE" button to go to the next screen.

# FULL SCREENS



## Full Screens Features and Options

The "Full Screens" menu displays large icon vessel and propulsion data screens. Several screens show a minimum and maximum reference with an arrow directing your attention to the current value displayed within the screen. The minimum and maximum reference limits are the same minimum and maximum limits that are shown on a System Link gauge. Additionally, a number of screens allow the resetting of peak RPM or speed data. The "Full Screens" must be turned on ("Yes") for these screens to be active in the "Full Screens" menu. The menu path to turn the full screens data on is: "Main Menu," > "Settings," > "Screens," > "Full Screens."

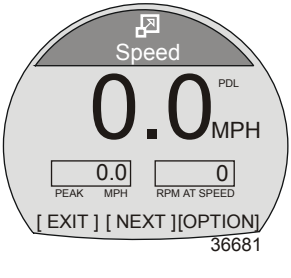

- The following list shows the available information for selecting full screens data.
  - Speed
  - Depth
  - Coolant temperature
  - Clock
  - Oil temperature
  - Fuel pressure
  - Oil pressure
  - Water pressure
  - Battery
  - Air temperature
  - Maintenance
  - RPM

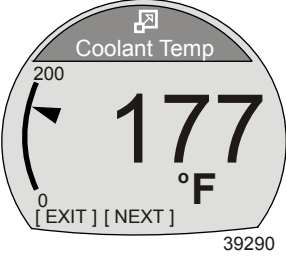
Speed	Displays large numbers for the vessel speed through the available sensor, the peak speed, and the peak RPM at speed. The peak values can be reset.	 The image shows a circular speed display screen. At the top, there is a small icon of a vessel and the word "Speed". The main display shows "0.0" in large digits, with "MPH" to its right and "PDL" above it. Below the main display, there are two smaller boxes: the left one shows "0.0" with "PEAK MPH" below it, and the right one shows "0" with "RPM AT SPEED" below it. At the bottom of the screen, there are three buttons: "[EXIT]", "[NEXT]", and "[OPTION]". The number "36681" is printed at the very bottom right of the screen.
-------	--	--

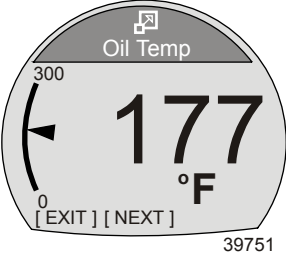
# FULL SCREENS

<p>Depth</p>	<p>Displays the water depth in large numbers.</p>	 <p>The screen displays 'Depth' at the top, a large '126' followed by 'FT', and '[EXIT] [NEXT]' at the bottom. A small icon of a screen with a cursor is in the top left. The number '36685' is at the bottom right.</p>
<p>Coolant Temperature</p>	<p>Displays the engine coolant temperature in large numbers and on a bar graph.</p>	 <p>The screen displays 'Coolant Temp' at the top, a large '177' followed by '°F', and '[EXIT] [NEXT]' at the bottom. A bar graph on the left shows a needle pointing to the value. The scale has '0' at the bottom and '200' at the top. A small icon of a screen with a cursor is in the top left. The number '39290' is at the bottom right.</p>
<p>Clock</p>	<p>Displays the time in large numbers. Can be displayed as 24 hour or 12 hour.</p>	 <p>The screen displays 'Clock' at the top, a large '23:15', and '[EXIT] [NEXT]' at the bottom. A small icon of a screen with a cursor is in the top left. The number '36702' is at the bottom right.</p>
<p>Oil Temperature</p>	<p>Displays the engine oil temperature in large numbers and on a bar graph.</p>	 <p>The screen displays 'Oil Temp' at the top, a large '177' followed by '°F', and '[EXIT] [NEXT]' at the bottom. A bar graph on the left shows a needle pointing to the value. The scale has '0' at the bottom and '300' at the top. A small icon of a screen with a cursor is in the top left. The number '39751' is at the bottom right.</p>

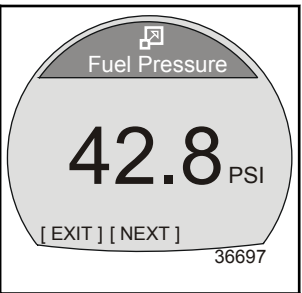
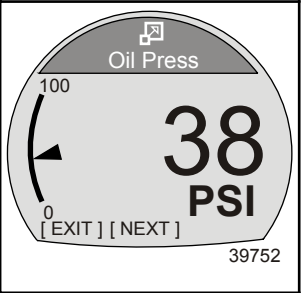
# FULL SCREENS

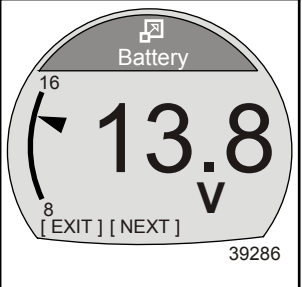
<p>Fuel Pressure</p>	<p>Displays the engine fuel pressure in large numbers.</p>	 <p>The Fuel Pressure full screen display features a semi-circular gauge at the top with the title 'Fuel Pressure' and a small icon. The main display area shows the value '42.8 PSI' in large, bold black text. Below the value are the controls '[EXIT] [NEXT]' and the ID number '36697'.</p>
<p>Oil Pressure</p>	<p>Displays the engine oil pressure in large numbers and on a bar graph.</p>	 <p>The Oil Pressure full screen display features a semi-circular gauge at the top with the title 'Oil Press' and a small icon. The gauge has a scale from 0 to 100. The needle points to a value of 38. The main display area shows '38 PSI' in large, bold black text. Below the value are the controls '[EXIT] [NEXT]' and the ID number '39752'.</p>
<p>Water Pressure</p>	<p>Displays the engine water pressure in large numbers and on a bar graph.</p>	 <p>The Water Pressure full screen display features a semi-circular gauge at the top with the title 'Water Press' and a small icon. The gauge has a scale from 0 to 30. The needle points to a value of 15.2. The main display area shows '15.2 PSI' in large, bold black text. Below the value are the controls '[EXIT] [NEXT]' and the ID number '40531'.</p>
<p>Battery</p>	<p>Displays the battery voltage level in large numbers and on a bar graph.</p>	 <p>The Battery full screen display features a semi-circular gauge at the top with the title 'Battery' and a small icon. The gauge has a scale from 8 to 16. The needle points to a value of 13.8. The main display area shows '13.8 V' in large, bold black text. Below the value are the controls '[EXIT] [NEXT]' and the ID number '39286'.</p>

# FULL SCREENS

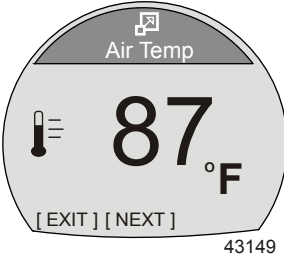
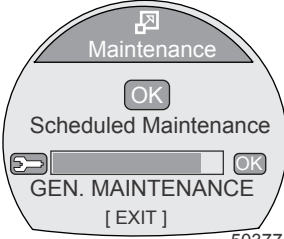
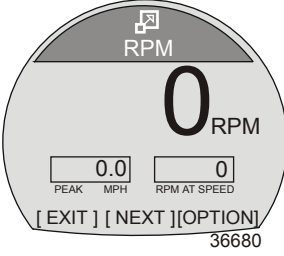
<p>Air Temperature</p>	<p>Displays the air temperature in large numbers.</p>	 <p>A circular full screen titled "Air Temp" showing a thermometer icon and the number "87°F". At the bottom, it has "[EXIT] [NEXT]" and the number "43149".</p>
<p>Maintenance</p>	<p>Estimates the amount of run time the engine accumulated since the last scheduled maintenance. Normal scheduled maintenance for the engine is 100 hours. The maintenance screen shows a bar graph approximating the amount of time remaining before a scheduled maintenance is required. The maintenance screen must be turned on for this screen to be displayed.</p>	 <p>A circular full screen titled "Maintenance" showing a bar graph and the text "Scheduled Maintenance" and "GEN. MAINTENANCE". It includes "OK" and "[EXIT]" buttons and the number "50377".</p>
<p>RPM</p>	<p>Displays large numbers for the engine RPM, shows the peak speed, and the peak RPM at speed. The peak values can be reset.</p>	 <p>A circular full screen titled "RPM" showing a large "0" and "RPM". It includes two small displays: "PEAK MPH" with "0.0" and "RPM AT SPEED" with "0". At the bottom, it has "[EXIT] [NEXT] [OPTION]" and the number "36680".</p>

## RESETTING PEAK VALUES

The "RPM" and "Speed" full screens will record and store the vessel peak speed and the RPM at that peak speed. These peak values can be reset to capture new RPM and speed data.

# FULL SCREENS

1. While the "RPM" or "Speed" full screen is visible, press the "+" button to open the reset option.

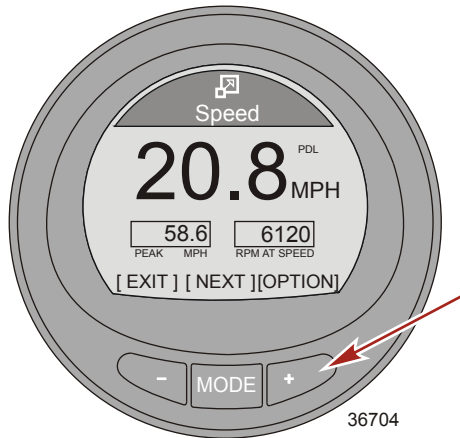

2. A pop-up window will appear asking if the peak values should be reset ("Reset Peak Values?").
3. Press the "+" button if you do not want to reset the values "[NO]."
4. Press the "-" button if you want to reset the values "[YES]."

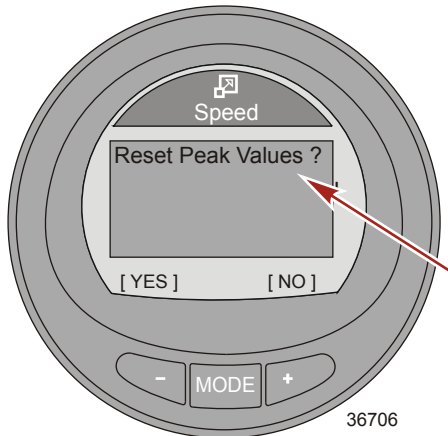

5. When the selection is "[YES]," the pop-up window will close and the new data will populate the peak values immediately.

# FULL SCREENS

## Maintenance Screen

Some 4-Stroke power package models can estimate the amount of time the engine has run since the last scheduled maintenance. Normal scheduled maintenance for the engine is every 100 hours. The maintenance screen shows a bar graph approximating the amount of time remaining before a scheduled maintenance is required. When the maintenance screen is reset, the bar graph will change to 100 hours before the next scheduled maintenance. The maintenance screen must be turned on for this screen to be displayed. Your owner's manual maintenance schedule should be followed regardless of what the gauge displays. To turn this feature on, refer to **Section 2: Settings—Turning the Screens On**.

1. While in the "Main Menu," use the "-" or "+" button to highlight the "Full Screens" option. Press "MODE" to open the "Full Screens" option.
2. Press the "MODE" button to page through the screens.
3. The "Maintenance" screen will show a bar graph approximating the amount of time remaining before a scheduled maintenance is required. Press the "MODE" to exit to the "Maintenance" screen.

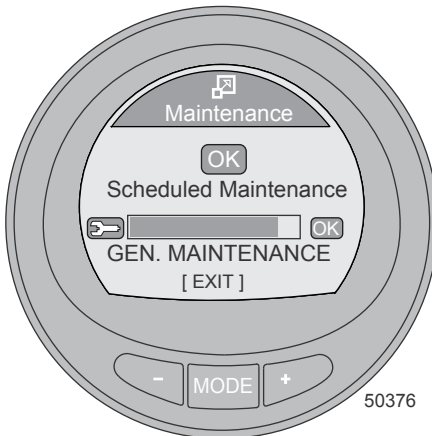



## FULL SCREENS

4. If the bar graph is not visible, the engine scheduled maintenance has passed 100 hours and the screen will change to "Perform Maintenance." Press "+" to begin the reset procedure.

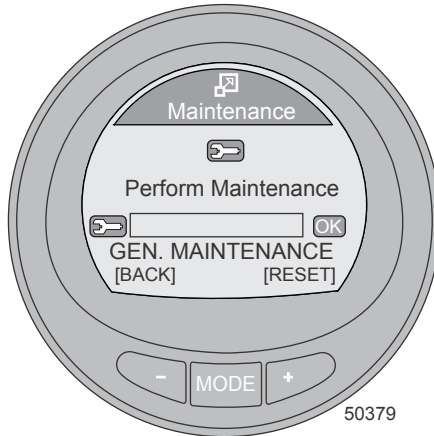

5. A window will pop up asking "HAS SCHEDULED MAINTENANCE BEEN PERFORMED?" Press the "+" button ("NO") to return to the "Maintenance" screen, or press the "-" button ("YES") to reset the scheduled maintenance screen.

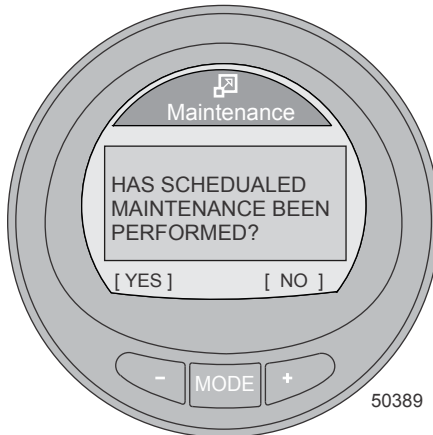

## FULL SCREENS

6. After pressing the "-" button ("YES") to reset the scheduled maintenance screen, the bar graph will reset to 100 hours. Press the "-" to exit the "Maintenance" window and return to the main menu, or press "NEXT" to exit the maintenance screen to the next full screen, or press "MENU" to repeat the scheduled maintenance reset process.

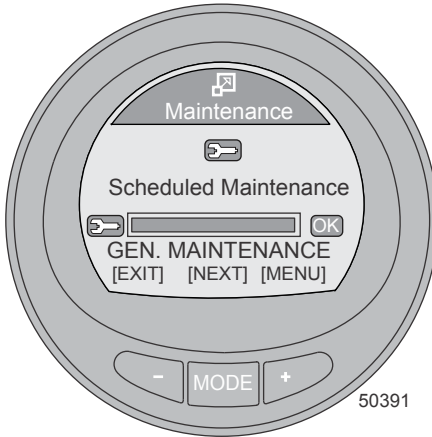

# FAVORITE SCREENS

## Favorites Screen Features and Options

The "Favorites" is an optional feature that will show specific screens selected by the operator to be reviewed quickly. The favorites will remain on the screen for a specific amount of time. This time can be one second up to 30 seconds. Up to nine favorite screens can be selected from the "Propulsion" menu, "Vessel" menu, or "Full Screens" menu. After selecting the screen desired to be displayed on the favorites, use the "-" or "+" button to highlight the "Favorites" menu option. Press the "MODE" button to view the favorites.

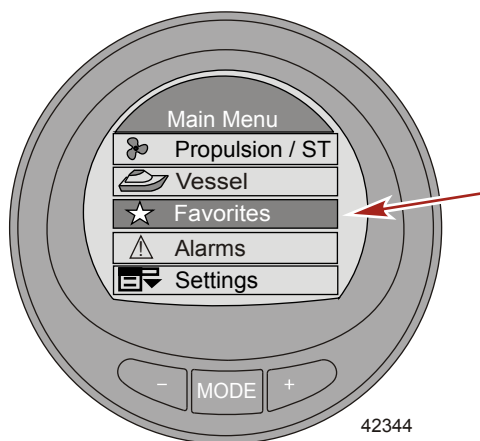

## SELECTING A FAVORITE SCREEN

1. From the "Main Menu," press the "-" or "+" button to select either the "Propulsion," "Vessel," or "Full Screens" menu.

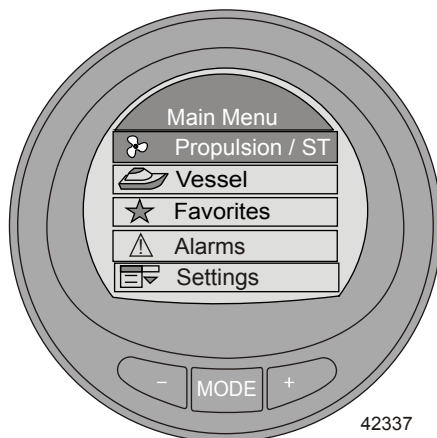

2. Press the "MODE" button to enter the selected menu.

# FAVORITE SCREENS

3. Press the "-" or "+" button and select a screen to be a favorite.

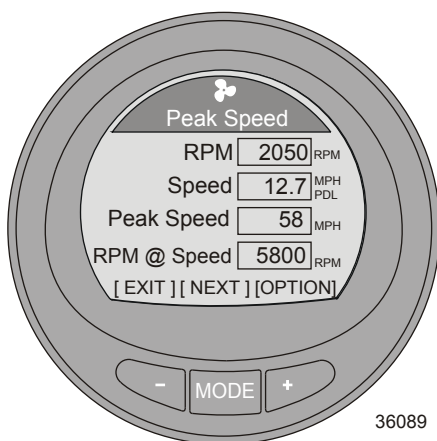

4. Press the "-" button and the "+" button at the same time and hold the buttons in until the pop-up window appears asking to add the screen to the favorites ("Add to Favorites?").

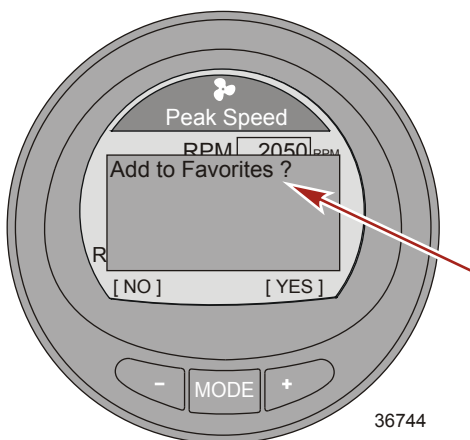

5. Press the "+" button to save the screen to the "Favorites" menu. If the screen is not wanted, press the "-" button to discard the screen option.
6. Press the "MODE" button to page through the menu to select a different screen, or press the "-" button to exit the menu and return to the "Main Menu."
7. Continue the selection process for up to nine selected favorites.

# FAVORITE SCREENS

## CHANGING THE FAVORITES SCREEN DURATION

The favorites individual screen will remain visible for a specific amount of time. This time can be set from one second up to 30 seconds.

1. To change the favorites screen duration, go to the "Main Menu" and press the "-" or "+" button to highlight the "Settings" menu.

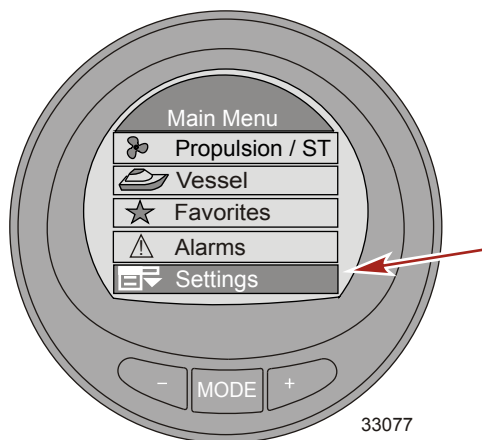

2. Press the "MODE" button to enter the "Settings" menu.
3. Press the "-" button to highlight the "Screens" menu.

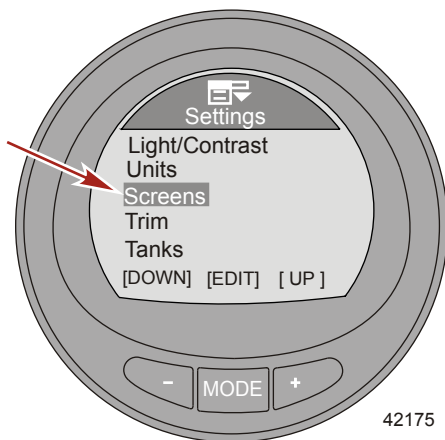

4. Press the "MODE" button to enter the "Screens" menu.
5. Press the "-" or "+" button to highlight the "Favorites Slide" option.
6. Press the "MODE" button to edit the number of seconds the favorites will display.

# FAVORITE SCREENS

7. Press the "-" or "+" button to change the number of seconds.

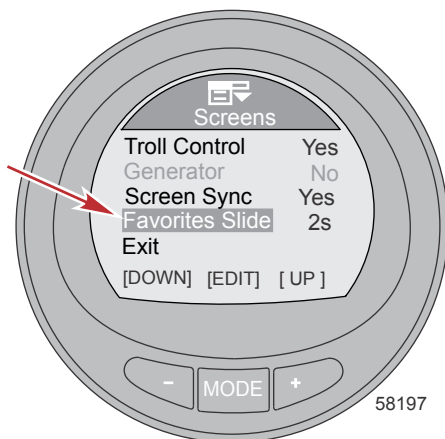

## DELETING A FAVORITE

1. Select the screen that is to be deleted.
2. Press the "-" button and the "+" button at the same time and hold the buttons in until the pop-up window appears asking to remove the screen from the favorites ("Remove from Favorites?").

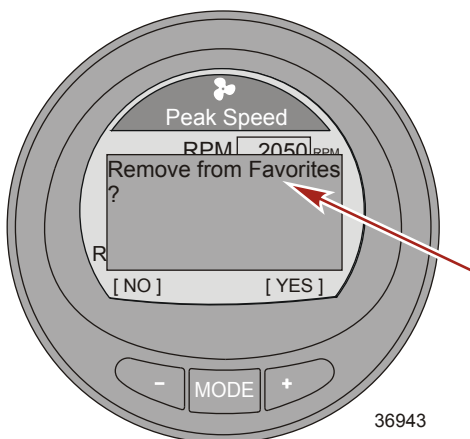

3. Press the "+" button to remove the screen from the "Favorites" menu. Press the "-" button to keep the screen as a favorite.
4. Press the "MODE" button to page through the menu to select a different screen, or press the "-" button to exit the menu and return to the "Main Menu."

# ALARMS

## Alarms Screen

The "Alarms" screen will display two different fault screens. The screen displays the flashing triangle for system related faults followed by the fault descriptive short text with the fault number. Press the "+" to view the fault descriptive long text, and the recommended action to take. A flashing "AL" will be in the upper right side of the screen.

1. To view all system alarms while in the "Main Menu," press the "-" or "+" button to highlight the "Alarms" menu option.
2. Press the "MODE" button to enter the "Alarms" menu option.

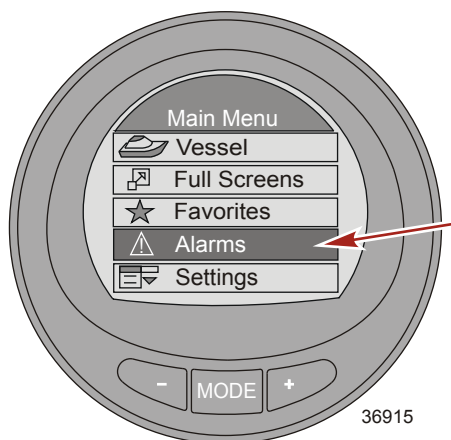

3. The first window will display a flashing triangle icon indicating there is a fault within the system. The window will quickly change to the descriptive text information.

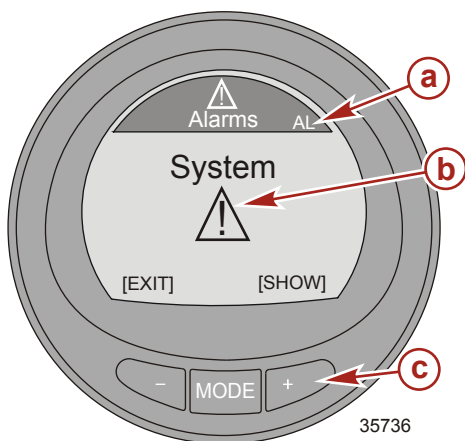

- a - Flashing "AL" alarm
- b - Flashing warning icon
- c - "+" button to show descriptive text

# ALARMS

4. The screen shows the fault location, fault code number, and the faulty component in short descriptive text.

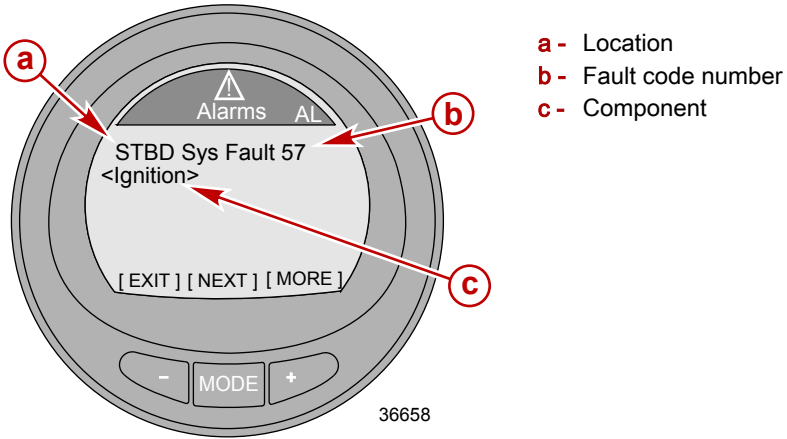

5. Press the "+" button to view the long descriptive text.

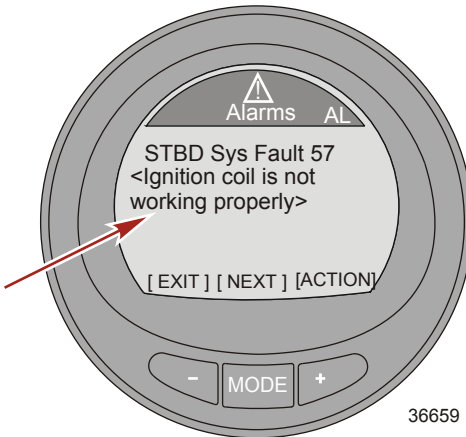



# ALARMS

6. Press the "+" button to view the recommended action to take.

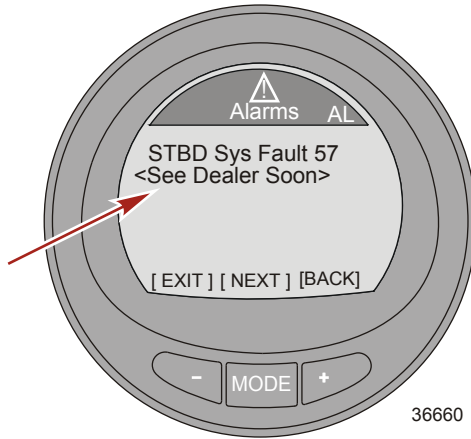

7. Press the "MODE" button to view the next fault text.

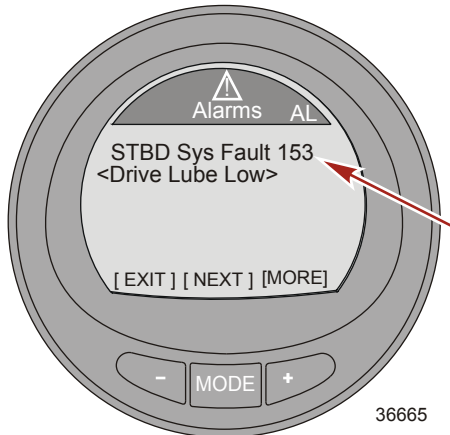

# ALARMS

8. Press the "+" button to view the long descriptive text. When the long descriptive text exceeds the screen capacity, several dots at the end of the screen text capacity will be visible.

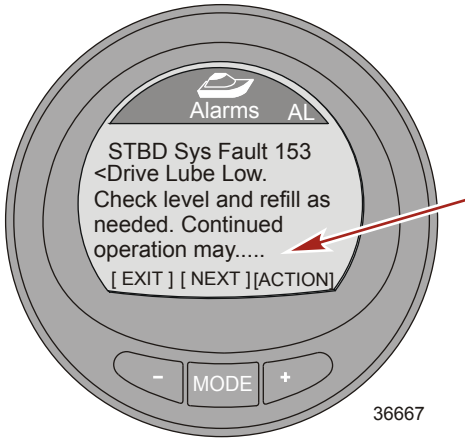

9. Press the "+" button to view the remaining long descriptive text.

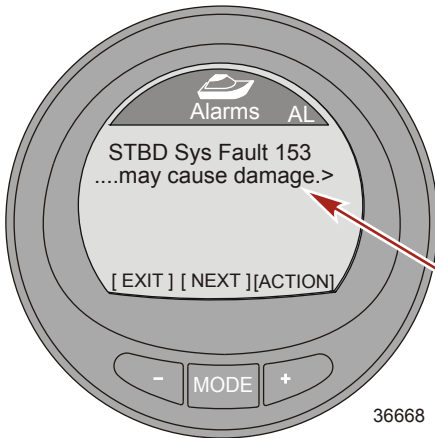

# ALARMS

10. Press the "+" button to view the recommended action to take.

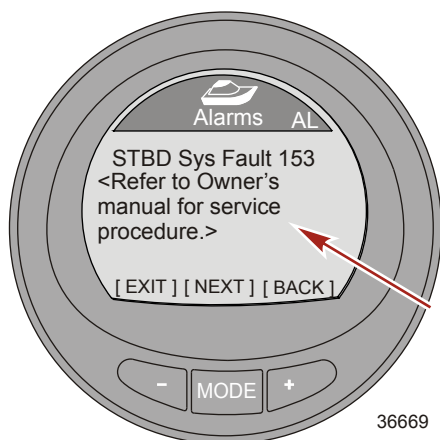

11. Press the "+" button to return to the short descriptive text fault screen, or press the "MODE" button to view the next alarm fault, or press the "-" button to exit the descriptive text screen.
12. Press the "-" button to exit the "Alarms" menu and return to the "Main Menu."

## EMISSION CONTROL ALARM WARNINGS WITH DESCRIPTIVE TEXT

When a problem is detected with the emission control system, a pop-up window with the "AL" flashing in the upper right-hand corner, an engine icon in the upper left-hand corner, "OBD Service Soon," and a large engine icon will be displayed on the screen. The screen will flash between two alarm displays. Pressing the "-" button while this screen is displayed will exit to the last screen that was on the monitor.

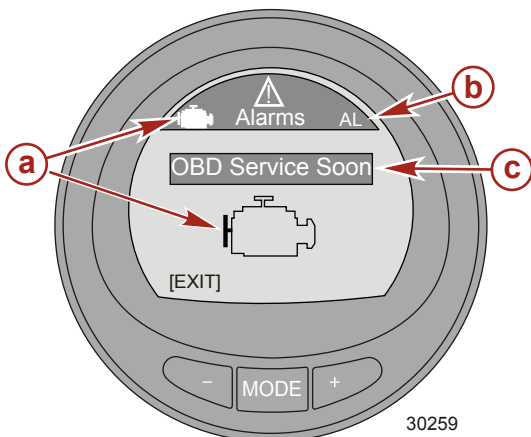

- a - Engine icon
- b - Flashing "AL"
- c - OBD Service Soon

# ALARMS

1. The second flashing alarm display shows the engine OBD icon, the flashing "AL," and warning icon. Press the "+" button for more information. This screen gives a more detailed description of the fault.

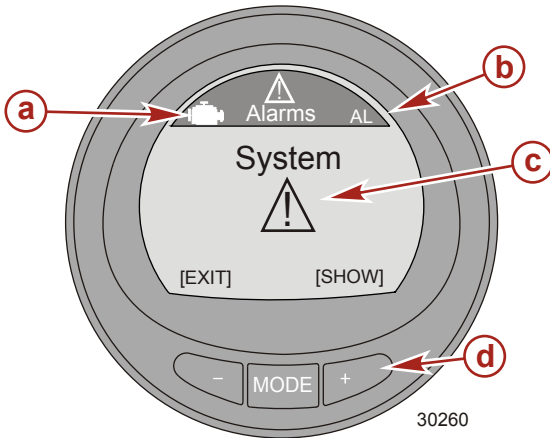

- a** - OBD icon
- b** - Flashing "AL" alarm
- c** - Flashing warning icon
- d** - "+" button to show descriptive text

# ALARMS

2. The screen displays the engine location, the system fault code number, and a description of the faulty component. Press the "+" button for more information. This screen gives a more detailed description of the fault.

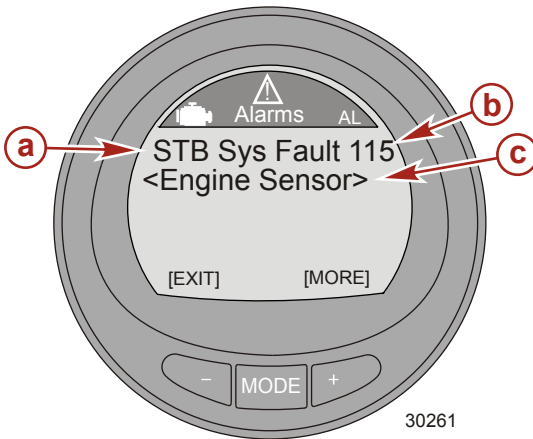

- a** - Engine location
- b** - Fault code
- c** - Fault description

3. A detailed description of the fault component is explained. Press the "+" button for information on a corrective action.

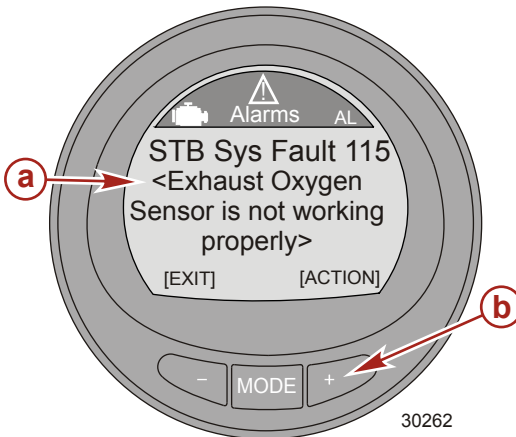

- a** - Detailed description of the fault component

# OWNERS ASSISTANCE

## Service Assistance

### PARTS AND ACCESSORIES INQUIRIES

Direct any inquiries concerning genuine Mercury Precision Parts® or Quicksilver Marine Parts and Accessories® to a local authorized dealer. Dealer have the proper systems to order parts and accessories for you if they are not in stock. **Engine model** and **serial number** are required order the correct parts.

### RESOLVING A PROBLEM

Satisfaction with your Mercury product is important to your dealer and to us. If you ever have a problem, question, or concern about your power package, contact your dealer or any authorized Mercury dealership. If you need additional assistance:

1. Talk with the dealership's sales manager or service manager.
2. If your question, concern, or problem cannot be resolved by your dealership, please contact the Mercury Marine Service Office for assistance. Mercury Marine will work with you and your dealership to resolve all problems.

The following information will be needed by the Customer Service:

- Your name and address
- Your daytime telephone number
- The model and serial numbers of your power package
- The name and address of your dealership
- The nature of the problem

### CONTACT INFORMATION FOR MERCURY MARINE CUSTOMER SERVICE

For assistance, call, fax, or write to the geographic office in your area. Please include your daytime telephone number with mail and fax correspondence.

United States, Canada		
Telephone	English +1 920 929 5040 Français +1 905 636 4751	Mercury Marine W6250 Pioneer Road P.O. Box 1939 Fond du Lac, WI 54936-1939
Fax	English +1 920 929 5893 Français +1 905 636 1704	
Website	www.mercurymarine.com	

Australia, Pacific		
Telephone	+61 3 9791 5822	Brunswick Asia Pacific Group 41-71 Bessemer Drive Dandenong South, Victoria 3175 Australia
Fax	+61 3 9706 7228	

# OWNERS ASSISTANCE

<b>Europe, Middle East, Africa</b>		
Telephone	+32 87 32 32 11	Brunswick Marine Europe Parc Industriel de Petit-Rechain B-4800 Verviers, Belgium
Fax	+32 87 31 19 65	

<b>Mexico, Central America, South America, Caribbean</b>		
Telephone	+1 954 744 3500	Mercury Marine 11650 Interchange Circle North Miramar, FL 33025 U.S.A.
Fax	+1 954 744 3535	

<b>Japan</b>		
Telephone	+072 233 8888	Kisaka Co., Ltd. 4-130 Kannabecho, Sakai-ku Sakai-shi, Osaka 590-0984, Japan
Fax	+072 233 8833	

<b>Asia, Singapore</b>		
Telephone	+65 65466160	Brunswick Asia Pacific Group T/A Mercury Marine Singapore Pte Ltd 29 Loyang Drive Singapore, 508944
Fax	+65 65467789	