

OUTPUT FLANGE
 (SAE NO. 510)

UNIT OF MEASURE in. (mm)	SCALE APROX. 1" = 1' 25.4mm = 304mm
-----------------------------	---

864760 SHEET 1 OF 2
 MIE 5.7L WITH VELVET DRIVE 5000A DOWN ANGLE TRANSMISSION

- NOTES:
 (1) DIMENSIONS REQUIRE A MINIMUM 1/2 in. (13mm) CLEARANCE FOR MOTOR MOUNT DEFLECTION.
 (2) DIMENSIONS APPLY TO POINT OF INTERSECTION OF OUTPUT SHAFT CENTERLINE AND OUTPUT FLANGE FACE.

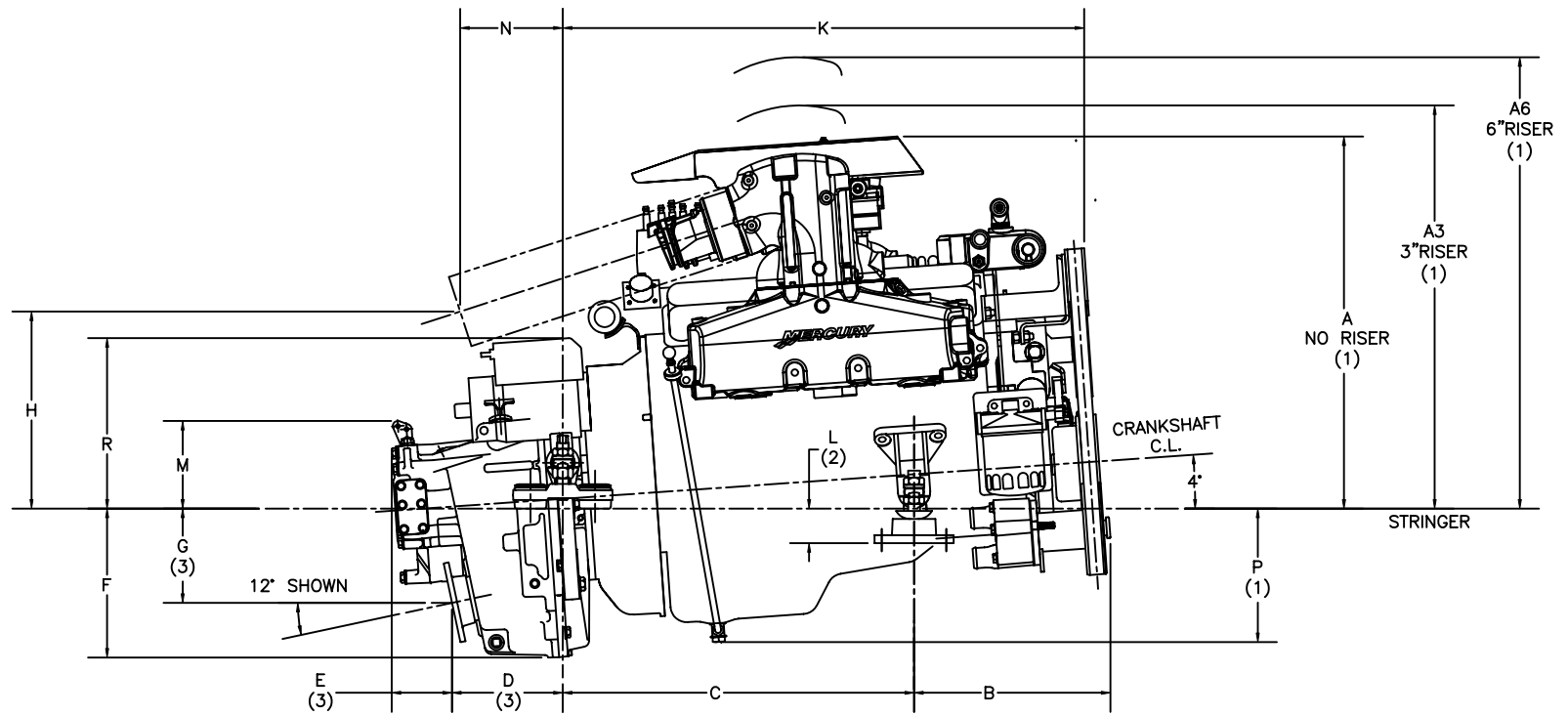

DIMENSIONS	PROPSHAFT ANGLE		
	10°	12°	15°
A STANDARD	567	583	613
A3 (3" RISER)	622	635	654
A6 (6" RISER)	698	711	730
B	299	309	310
C	551	553	555
D	182	174	163
E	87	95	108
F	235	235	235
G	142	148	157
H	316	310	302
K	832	821	802
L	74	54	25
M	147	138	124
N	153	162	174
P	218	210	197
R	268	269	269

METRIC
MM.

DIMENSIONS	PROPSHAFT ANGLE		
	10°	12°	15°
A STANDARD	22-5/16	22-15/16	24-1/8
A3 (3" RISER)	24-1/2	25	25-3/4
A6 (6" RISER)	27-1/2	28	28-3/4
B	11-3/4	12-3/16	12-3/16
C	21-11/16	21-3/4	21-7/8
D	7-3/16	6-7/8	6-3/8
E	3-7/16	3-3/4	4-1/4
F	9-1/4	9-1/4	9-1/4
G	5-5/8	5-13/16	6-3/16
H	12-7/16	12-1/4	11-7/8
K	32-3/4	32-5/16	31-9/16
L	2-7/8	2-1/8	1
M	5-3/16	5-7/16	4-7/8
N	6	6-3/8	6-13/16
P	8-5/8	8-1/4	7-3/4
R	10-9/16	10-9/16	10-9/16

ENGLISH
IN.

864760 SHEET 2 OF 2
MIE 5.7L WITH VELVET DRIVE 5000A DOWN ANGLE TRANSMISSION.

NOTES:

- (1) DIMENSIONS REQUIRE A MINIMUM 1/2 in. (13mm) CLEARANCE FOR MOTOR MOUNT DEFLECTION.
- (2) BASE OF MOUNT TO BE PARALLEL TO STRINGER. MOUNTS SHOWN AT CENTER OF ADJUSTMENT.
- (3) DIMENSIONS APPLY TO POINT OF INTERSECTION OF OUTPUT SHAFT CENTERLINE AND OUTPUT FLANGE FACE.