

ITEM NUMBER  
4953732

REVISIONS			
ZONE	REV	DESCRIPTION	APP'D
01	REVISED		

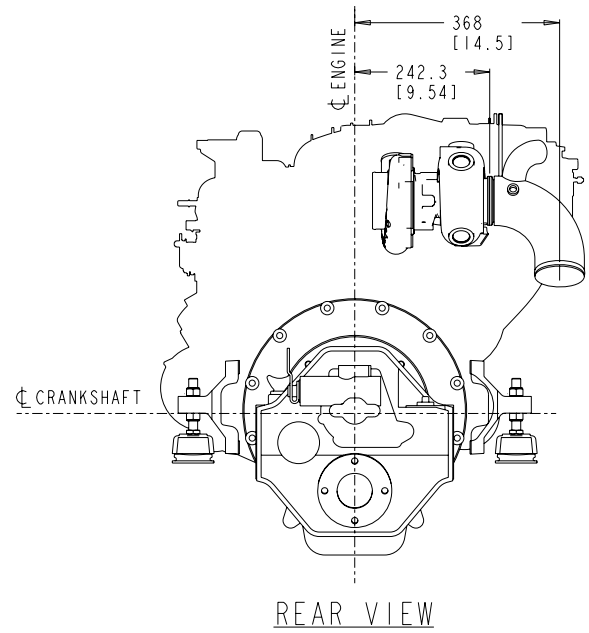

- NOTES:
1. DIMENSIONS REQUIRE A MINIMUM 13mm [1/2] CLEARANCE FOR MOTOR MOUNT DEFLECTION.
  2. FRONT AND REAR ENGINE MOUNTS ADJUST 8mm [5/16] UP OR DOWN.
  3. DIMENSIONS APPLY TO POINT OF INTERSECTION OF OUTPUT SHAFT CENTERLINE AND OUTPUT FLANGE FACE.
  4. SECURE SEAWATER HOSE INLET AWAY FROM ALTERNATOR BELT.
  5. SHOWN WITH ZF 63A TRANSMISSION.
  6. FOR CORRECT CABIN/WATER HEATER CONNECTION, REFER TO INSTALLATION MANUAL.
  7. NUMBERS INSIDE BRACKETS ARE IN INCHES.

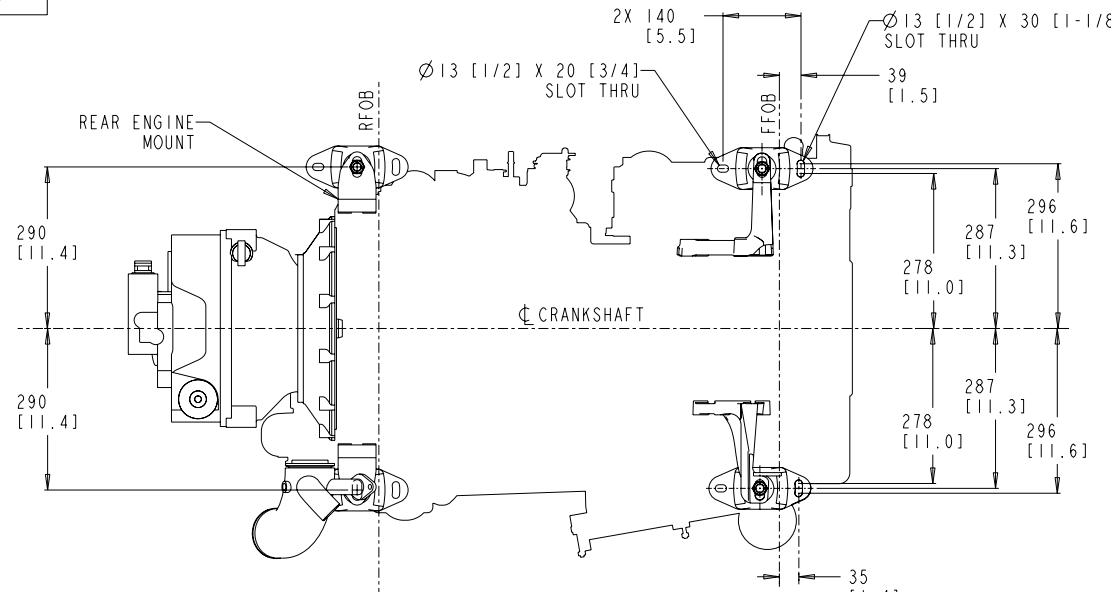
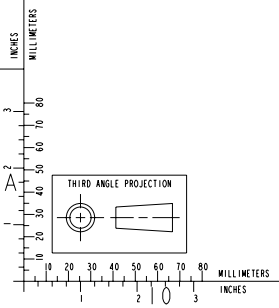
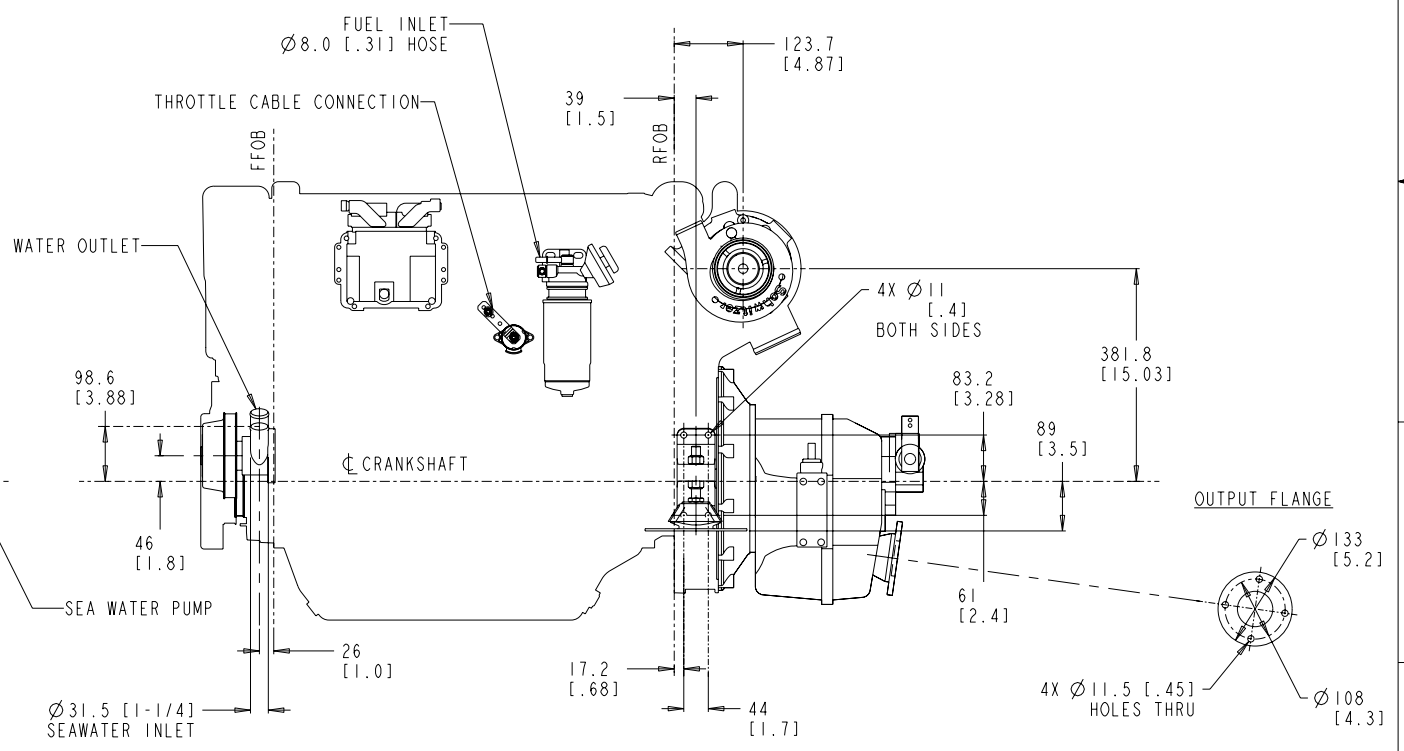
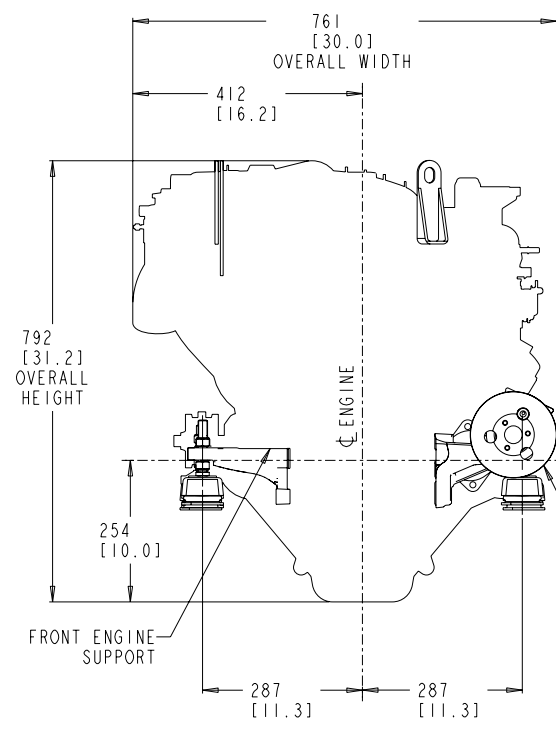
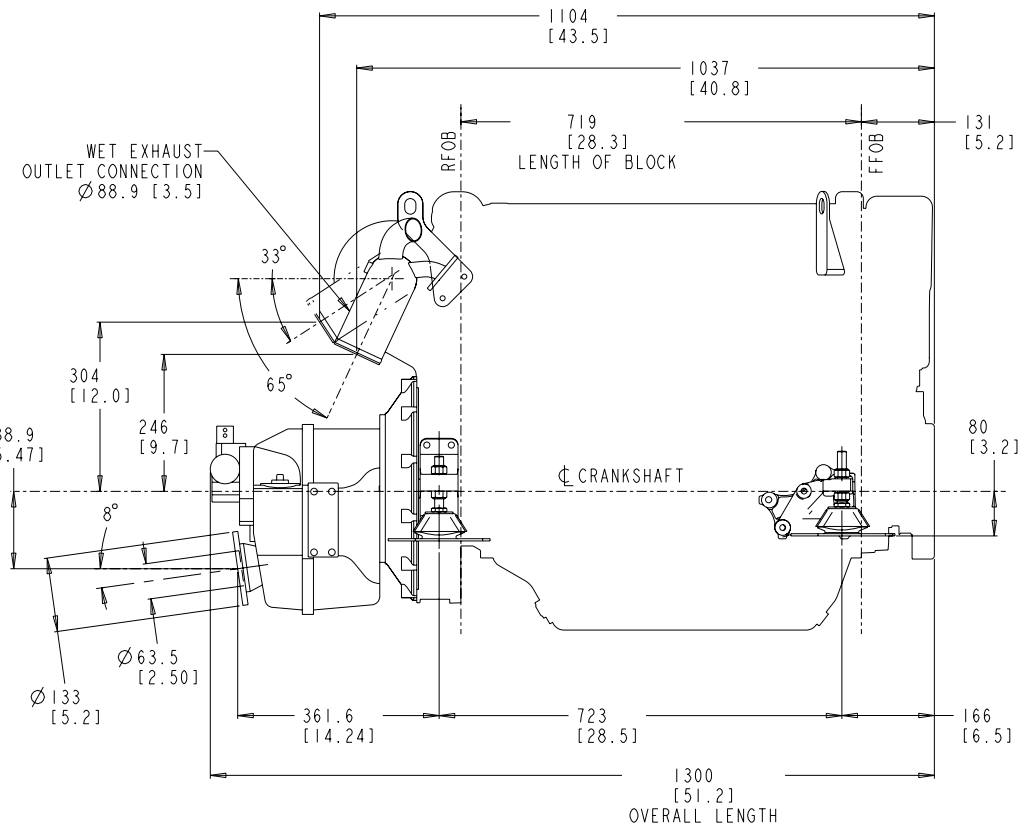

THIS DRAWING IS BASED ON CONFIG. NO. D913003MX03

PRODUCT GRAPHICS FILE  
NO ORIGINAL DRAWING EXISTS FOR THIS ITEM. THE ENGINEERING GRAPHICS DATA FOR THIS ITEM RESIDES IN THE PRODUCT GRAPHICS FILE AND IS CONTROLLED BY THE AGENCY DESIGNATED AS HAVING ITEM CONTROL.

DO NOT SCALE THIS DRAWING  
THIS DRAWING/DATA FILE (AND THE INFORMATION SHOWN THEREON) IS CONFIDENTIAL AND PROPRIETARY AND SHALL NOT BE USED, DISCLOSED TO OTHERS, OR REPRODUCED BY ANY MEANS FOR ANY PURPOSE IN HARD COPY FORM OR IN MACHINE READABLE FILES, WITHOUT WRITTEN CONSENT OF CUMMINS INC., MARKETING CAD SERVICES DEPARTMENT.

LAST SECTION LETTER USED: <b>NA</b>	REF. DRAWING STANDARDS: ANSI Y14.5M ISO 81101	<b>CUMMINS INC.</b>	
UNLESS OTHERWISE SPECIFIED DIMENSIONS ARE IN: MM ( ) ARE IN: IN	ITEM NAME 4.2L-ME TIER 2 W/ ZF63A	IDENTIFIER <b>J</b>	ITEM NUMBER 4953732
DWN: D. SOMIN	DATE: 04-20-04	SCALE: 2:1	ITEM CONTROL: MCS
CHD: UNCHECKED	APPD: [Signature]	SHEET 1 OF 1	