

864680 SHEET 2 OF 2
4.3L MPI BRAVO MULTI-POINT DRAIN

NOTES:

- (1) DIMENSIONS REQUIRE A MINIMUM 1/2 in. (13mm) CLEARANCE FOR MOTOR MOUNT DEFLECTION.
- (2) SELECT THE APPROPRIATE EXHAUST RISE-HEIGHT TO MAINTAIN A MINIMUM OF 13 in. (330mm) BETWEEN THE TOP OF THE EXHAUST ELBOW AND THE WATERLINE OF THE BOAT AT MAXIMUM RATED LOAD.
- (3) EXHAUST OUTLETS MUST BE ABOVE WATERLINE OF BOAT AT MAXIMUM RATED LOAD.

UNIT OF MEASURE	SCALE
in. [mm]	1" = 1' 25.4mm = 304mm

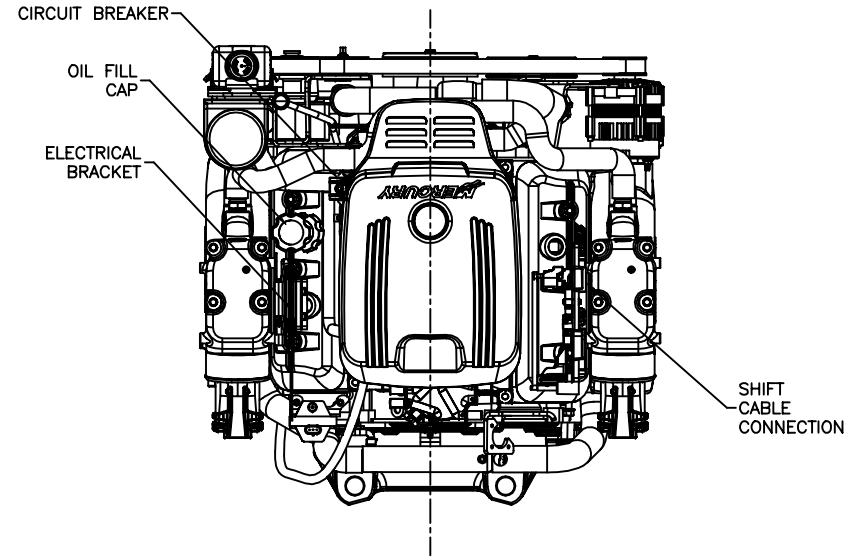

EXHAUST OUTLET DIA 4"
(102) X 2"(51) LONG
(2)(3)

REMOTE OIL FILTER

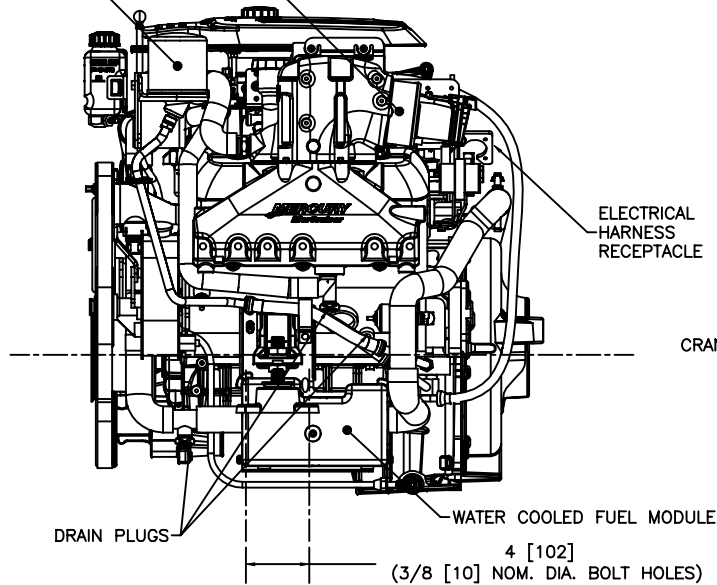

(-) BATTERY TERMINAL CONNECTION

