

OPTIONAL INTERMEDIATE EXHAUST ELBOW

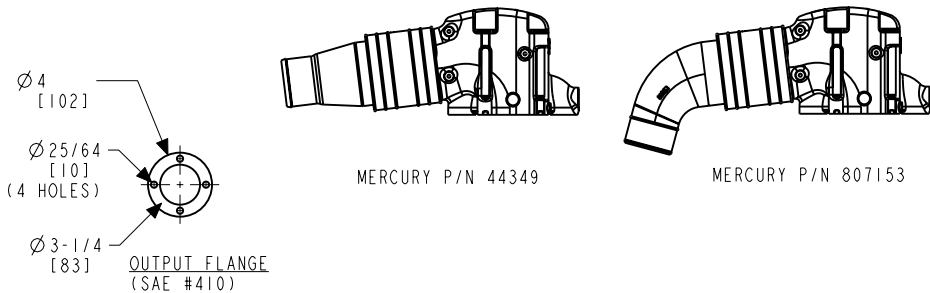

90-864750-004 SHEET 1 OF 5
350 MAG MPI, TOW SPORTS
WITH VELVET DRIVE 71C IN-LINE TRANSMISSION

UNIT OF MEASURE
in. (mm)

SCALE
1" = 1'
25.4 mm = 305 mm

NOTES:

- (1) DIMENSIONS REQUIRE A MINIMUM OF 1/2 in. (13 mm) CLEARANCE FOR MOTOR MOUNT DEFLECTION.
- (2) SELECT THE APPROPRIATE EXHAUST RISE-HEIGHT TO MAINTAIN A MINIMUM OF 1 in. (381 mm) BETWEEN THE TOP OF THE EXHAUST ELBOW AND THE WATERLINE OF THE BOAT AT MAXIMUM RATED LOAD.
- (3) DIMENSIONS APPLY TO POINT OF INTERSECTION OF OUTPUT SHAFT CENTERLINE AND OUTPUT FLANGE FACE.
- (4) DIMENSIONS TO SEA WATER PUMP INLET.
- (5) BASE OF MOUNT TO BE PARALLEL TO STRINGER. MOUNTS SHOWN AT CENTER OF ADJUSTMENT.

NOTES:

- (1) DIMENSIONS REQUIRE A MINIMUM OF 1/2 in. (13 mm) CLEARANCE FOR MOTOR MOUNT DEFLECTION.
- (2) SELECT THE APPROPRIATE EXHAUST RISE-HEIGHT TO MAINTAIN A MINIMUM OF 1 in. (381 mm) BETWEEN THE TOP OF THE EXHAUST ELBOW AND THE WATERLINE OF THE BOAT AT MAXIMUM RATED LOAD.
- (3) DIMENSIONS APPLY TO POINT OF INTERSECTION OF OUTPUT SHAFT CENTERLINE AND OUTPUT FLANGE FACE.
- (4) DIMENSIONS TO SEA WATER PUMP INLET.
- (5) BASE OF MOUNT TO BE PARALLEL TO STRINGER. MOUNTS SHOWN AT CENTER OF ADJUSTMENT.

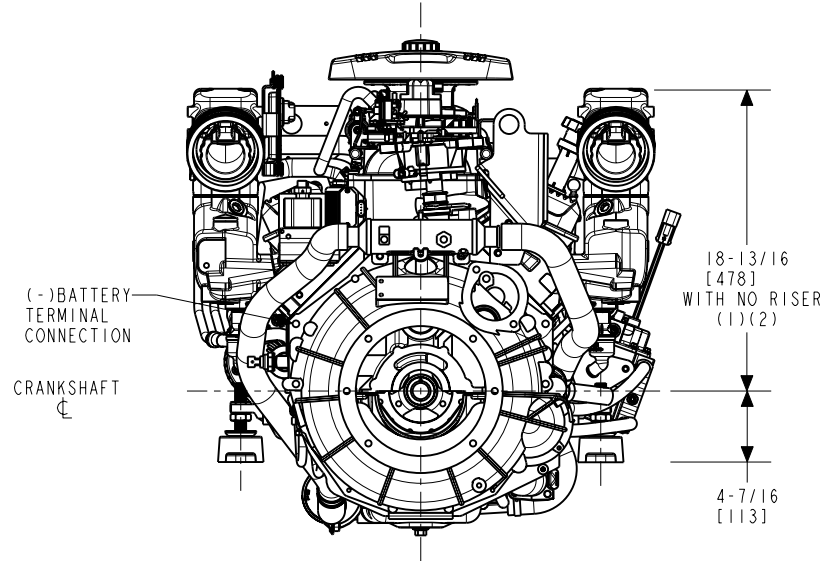
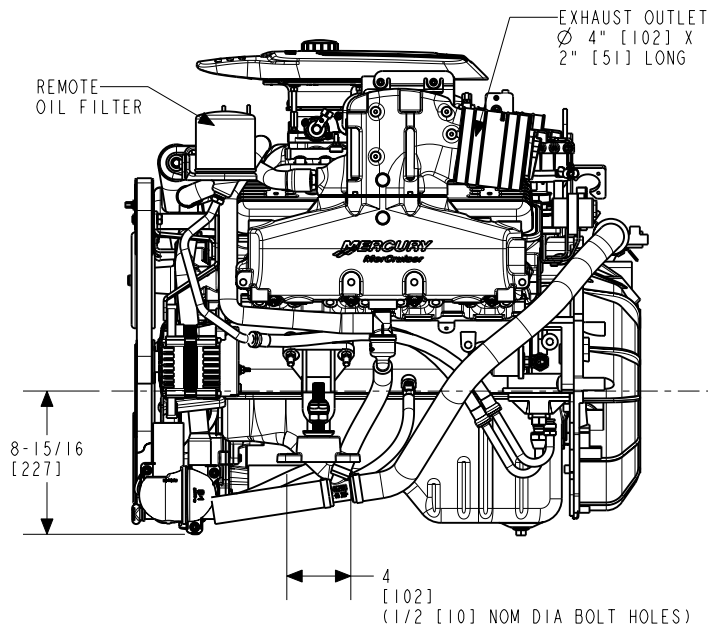
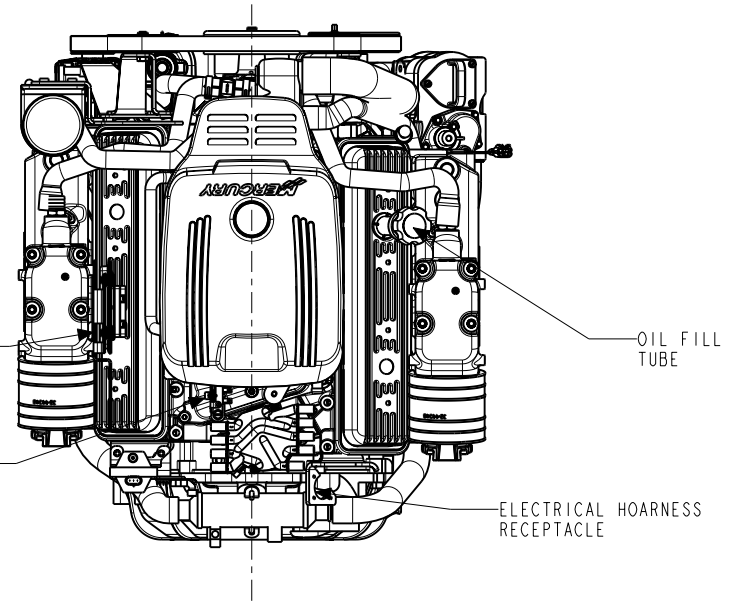

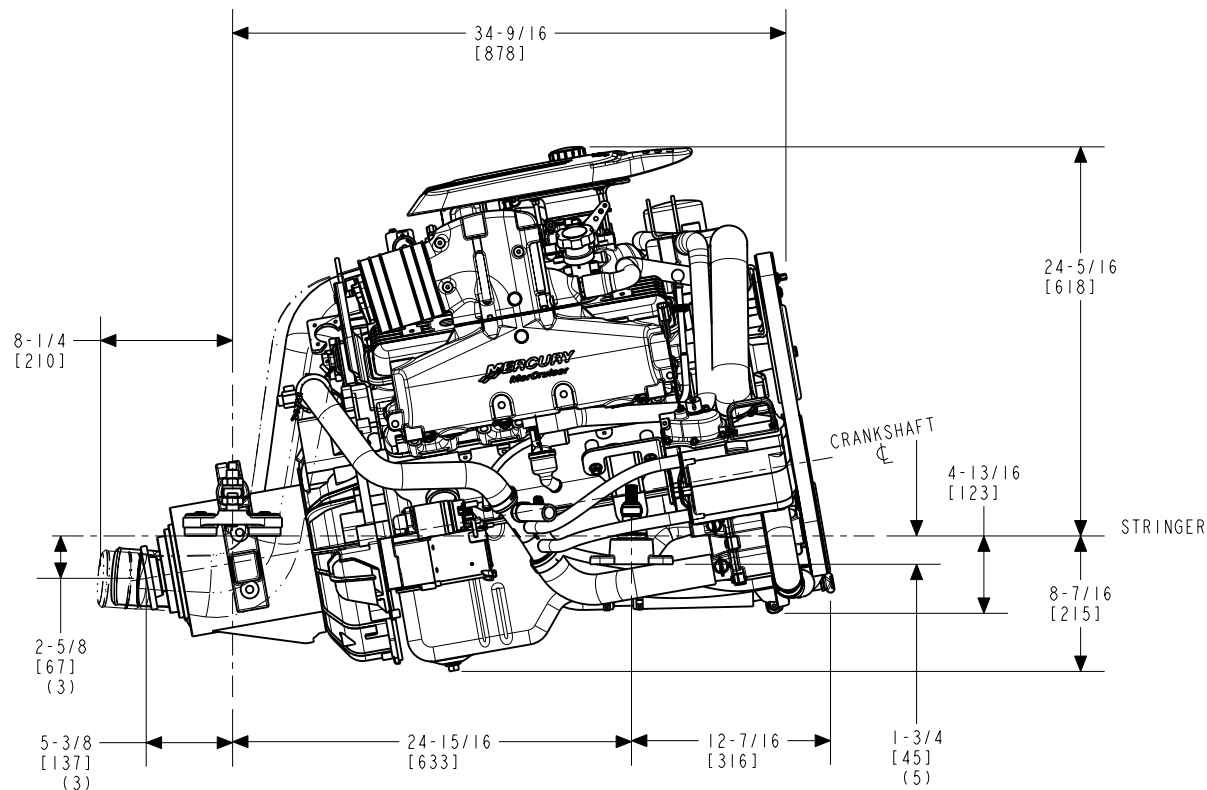

10° PROPSHAFT ANGLE SHOWN

90-864750-004 SHEET 3 OF 5
350 MAG MPI, TOW SPORTS
WITH VELVET DRIVE 71C IN-LINE TRANSMISSION

UNIT OF MEASURE
in. (mm)

SCALE
1" = 1'
25.4 mm = 305 mm

NOTES:

- (1) DIMENSIONS REQUIRE A MINIMUM OF 1/2 in. (13 mm) CLEARANCE FOR MOTOR MOUNT DEFLECTION.
- (2) SELECT THE APPROPRIATE EXHAUST RISE-HEIGHT TO MAINTAIN A MINIMUM OF 1 in. (381 mm) BETWEEN THE TOP OF THE EXHAUST ELBOW AND THE WATERLINE OF THE BOAT AT MAXIMUM RATED LOAD.
- (3) DIMENSIONS APPLY TO POINT OF INTERSECTION OF OUTPUT SHAFT CENTERLINE AND OUTPUT FLANGE FACE.
- (4) DIMENSIONS TO SEA WATER PUMP INLET.
- (5) BASE OF MOUNT TO BE PARALLEL TO STRINGER. MOUNTS SHOWN AT CENTER OF ADJUSTMENT.

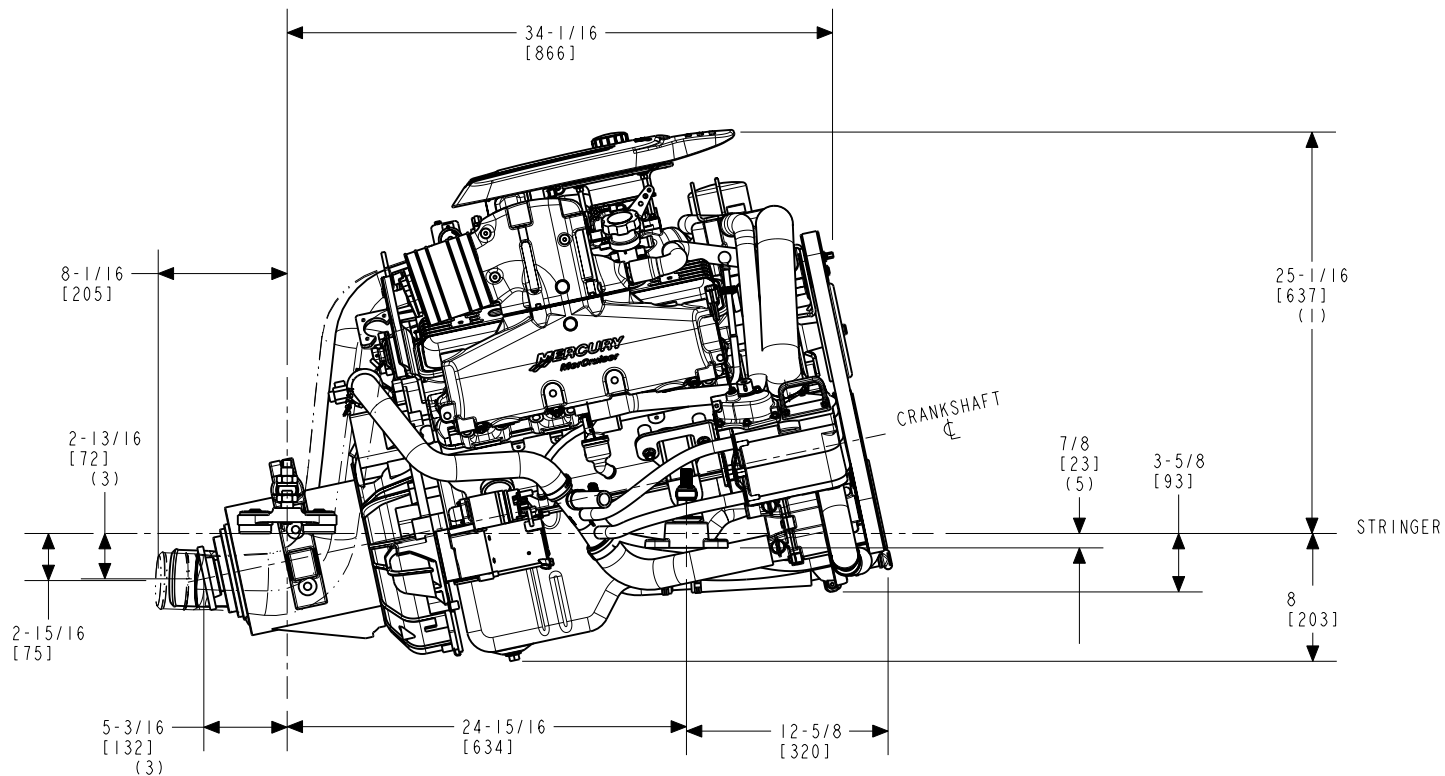

12° PROPSHAFT ANGLE SHOWN

90-864750-004 SHEET 4 OF 5
350 MAG MPI, TOW SPORTS
WITH VELVET DRIVE 71C IN-LINE TRANSMISSION

UNIT OF MEASURE
in. (mm)

SCALE
1" = 1'
25.4 mm = 305 mm

NOTES:

- (1) DIMENSIONS REQUIRE A MINIMUM OF 1/2 in. (13 mm) CLEARANCE FOR MOTOR MOUNT DEFLECTION.
- (2) SELECT THE APPROPRIATE EXHAUST RISE-HEIGHT TO MAINTAIN A MINIMUM OF 1 in. (381 mm) BETWEEN THE TOP OF THE EXHAUST ELBOW AND THE WATERLINE OF THE BOAT AT MAXIMUM RATED LOAD.
- (3) DIMENSIONS APPLY TO POINT OF INTERSECTION OF OUTPUT SHAFT CENTERLINE AND OUTPUT FLANGE FACE.
- (4) DIMENSIONS TO SEA WATER PUMP INLET.
- (5) BASE OF MOUNT TO BE PARALLEL TO STRINGER. MOUNTS SHOWN AT CENTER OF ADJUSTMENT.

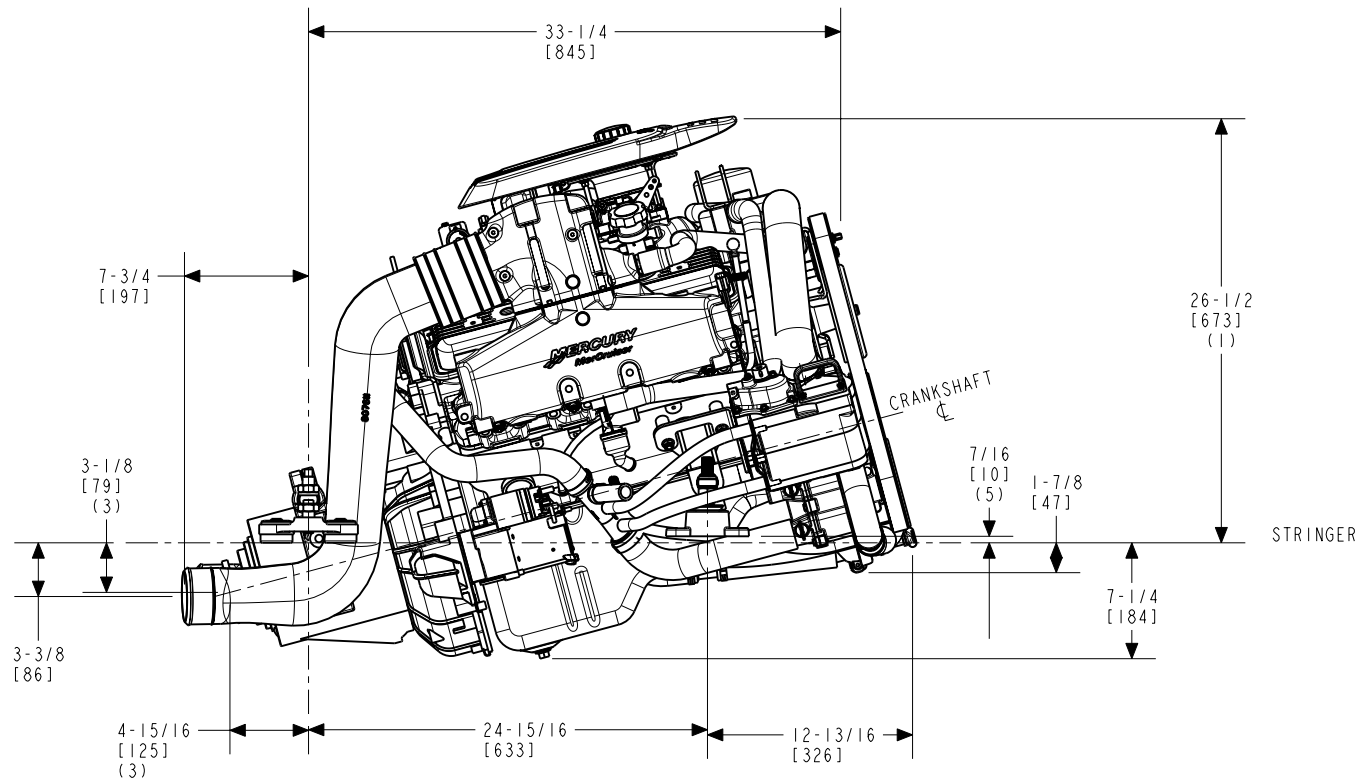

15° PROPSHAFT ANGLE SHOWN

90-864750-004 SHEET 5 OF 5
350 MAG MPI, TOW SPORTS
WITH VELVET DRIVE 7IC IN-LINE TRANSMISSION

UNIT OF MEASURE
in. (mm)

SCALE
1" = 1'
25.4 mm = 305 mm

NOTES:

- (1) DIMENSIONS REQUIRE A MINIMUM OF 1/2 in. (13 mm) CLEARANCE FOR MOTOR MOUNT DEFLECTION.
- (2) SELECT THE APPROPRIATE EXHAUST RISE-HEIGHT TO MAINTAIN A MINIMUM OF 1 in. (381 mm) BETWEEN THE TOP OF THE EXHAUST ELBOW AND THE WATERLINE OF THE BOAT AT MAXIMUM RATED LOAD.
- (3) DIMENSIONS APPLY TO POINT OF INTERSECTION OF OUTPUT SHAFT CENTERLINE AND OUTPUT FLANGE FACE.
- (4) DIMENSIONS TO SEA WATER PUMP INLET.
- (5) BASE OF MOUNT TO BE PARALLEL TO STRINGER. MOUNTS SHOWN AT CENTER OF ADJUSTMENT.