

UNIT OF MEASURE	SCALE
in. [mm]	1" = 1'
	25.4mm = 304mm

864750 SHEET 1 OF 4
 MIE 350 MAG MPI. TOW SPORTS WITH VELVET DRIVE
 71C IN-LINE TRANSMISSION

NOTES:
 (1) DIMENSIONS REQUIRE A MINIMUM 1/2 in. (13mm) CLEARANCE FOR MOTOR MOUNT DEFLECTION.
 (2) DIMENSIONS TO SEA WATER PUMP INLET.

864750 SHEET 2 OF 4
 MIE 350 MAG MPL TOW SPORTS WITH VELVET DRIVE
 71C IN-LINE TRANSMISSION

NOTES:

NOTES:

- (1) DIMENSIONS REQUIRE A MINIMUM 1/2 in. (13mm) CLEARANCE FOR MOTOR MOUNT DEFLECTION.
- (2) SELECT THE APPROPRIATE EXHAUST RISE-HEIGHT TO MAINTAIN A MINIMUM OF 13 in. (330mm) BETWEEN THE TOP OF THE EXHAUST ELBOW AND THE WATERLINE OF THE BOAT AT MAXIMUM RATED LOAD.
- (3) EXHAUST OUTLETS MUST BE ABOVE WATERLINE OF BOAT AT MAXIMUM RATED LOAD.

UNIT OF MEASURE	SCALE
in. [mm]	1" = 1' 25.4mm = 304mm

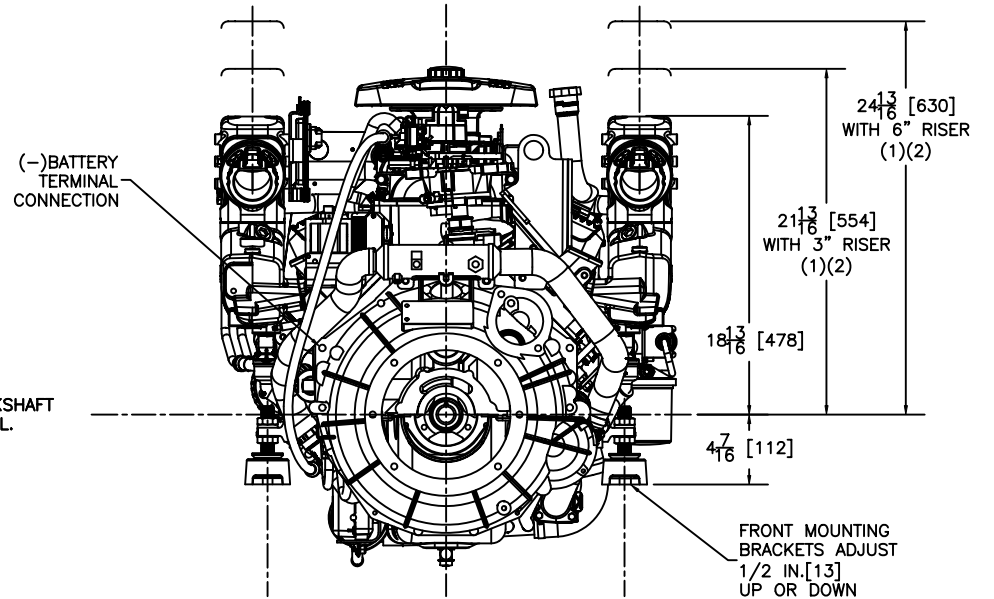
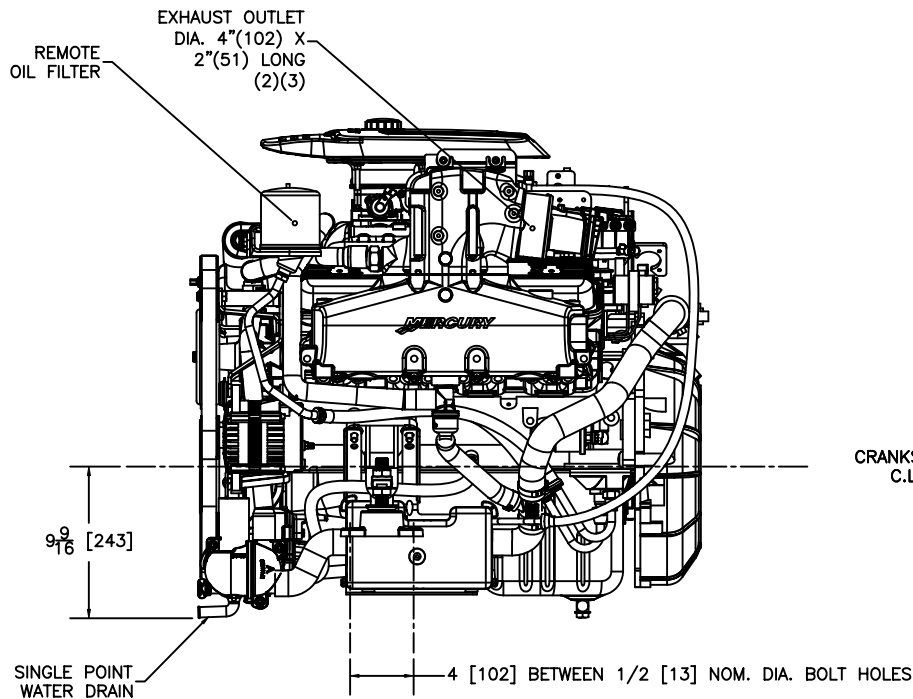
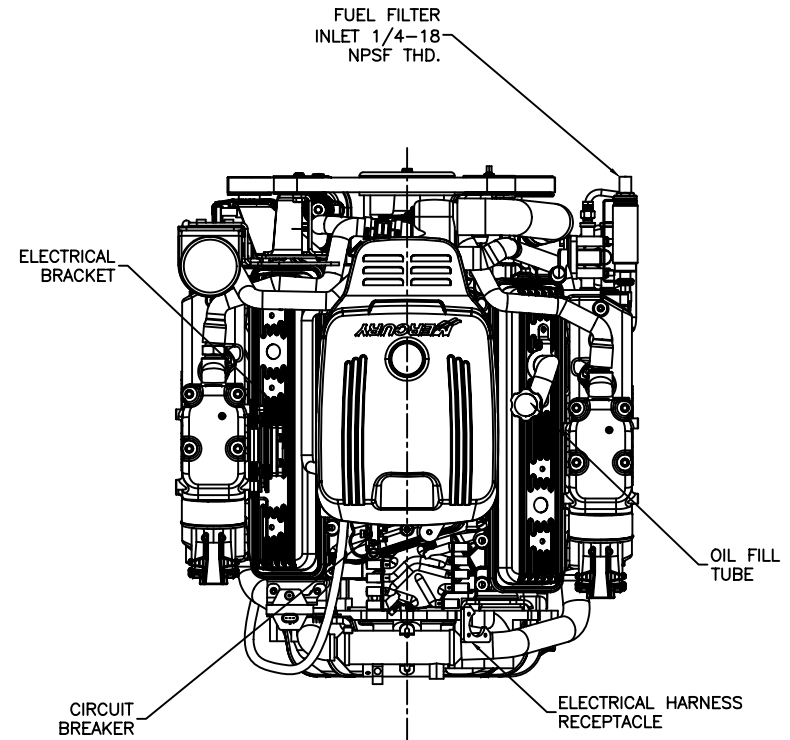

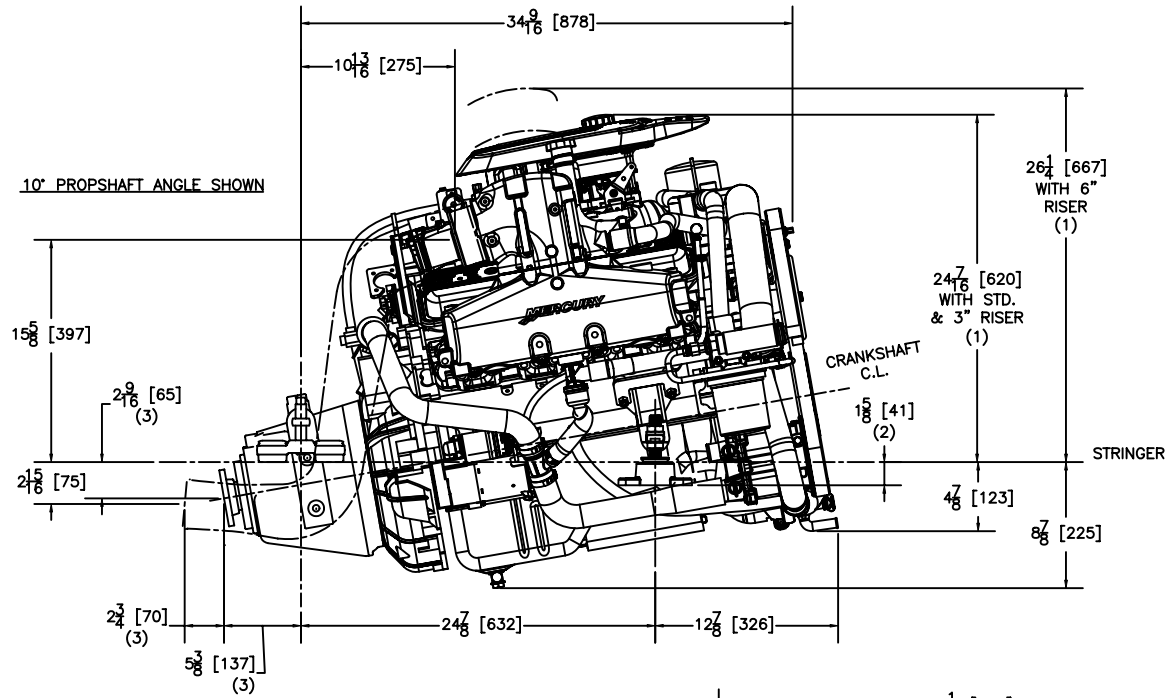

864750 SHEET 3 OF 4
MIE 350 MAG MPI, TOW SPORTS WITH VELVET DRIVE
71C IN-LINE TRANSMISSION

NOTES:

- (1) DIMENSIONS REQUIRE A MINIMUM 1/2 in. (13mm) CLEARANCE FOR MOTOR MOUNT DEFLECTION.
- (2) BASE OF MOUNT TO BE PARALLEL TO STRINGER. MOUNTS SHOWN AT CENTER OF ADJUSTMENT.
- (3) DIMENSIONS APPLY TO POINT OF INTERSECTION OF OUTPUT SHAFT CENTERLINE AND OUTPUT FLANGE FACE.

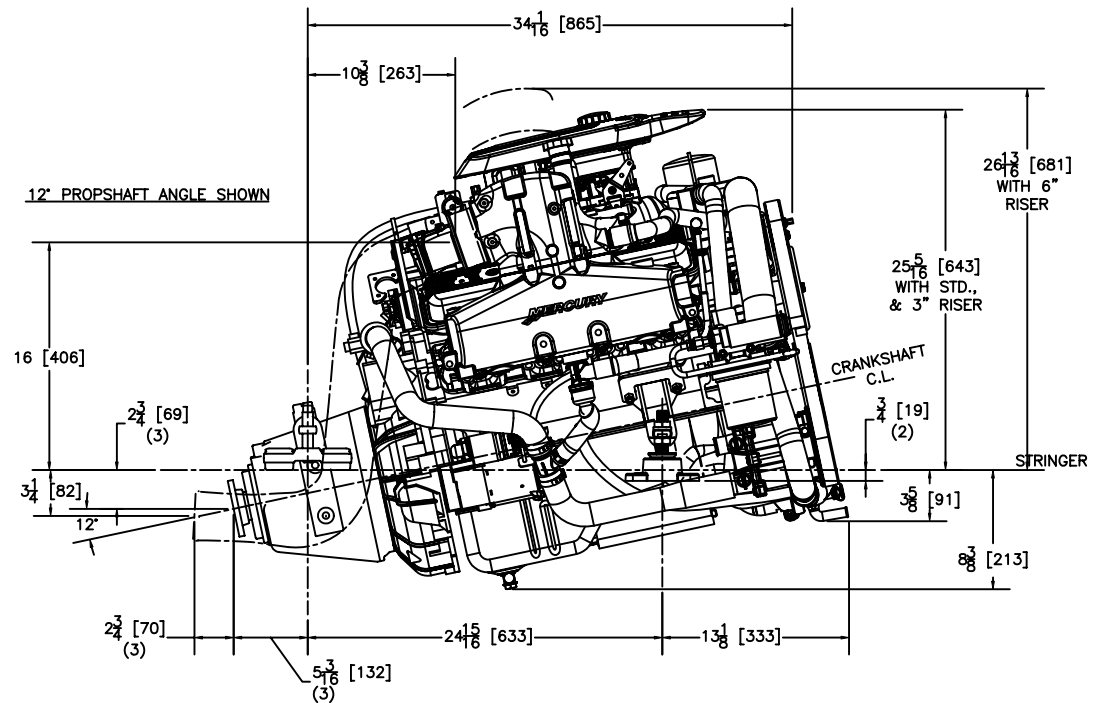

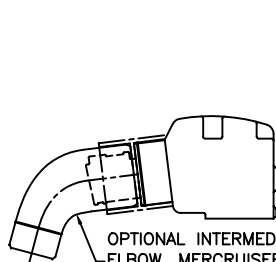
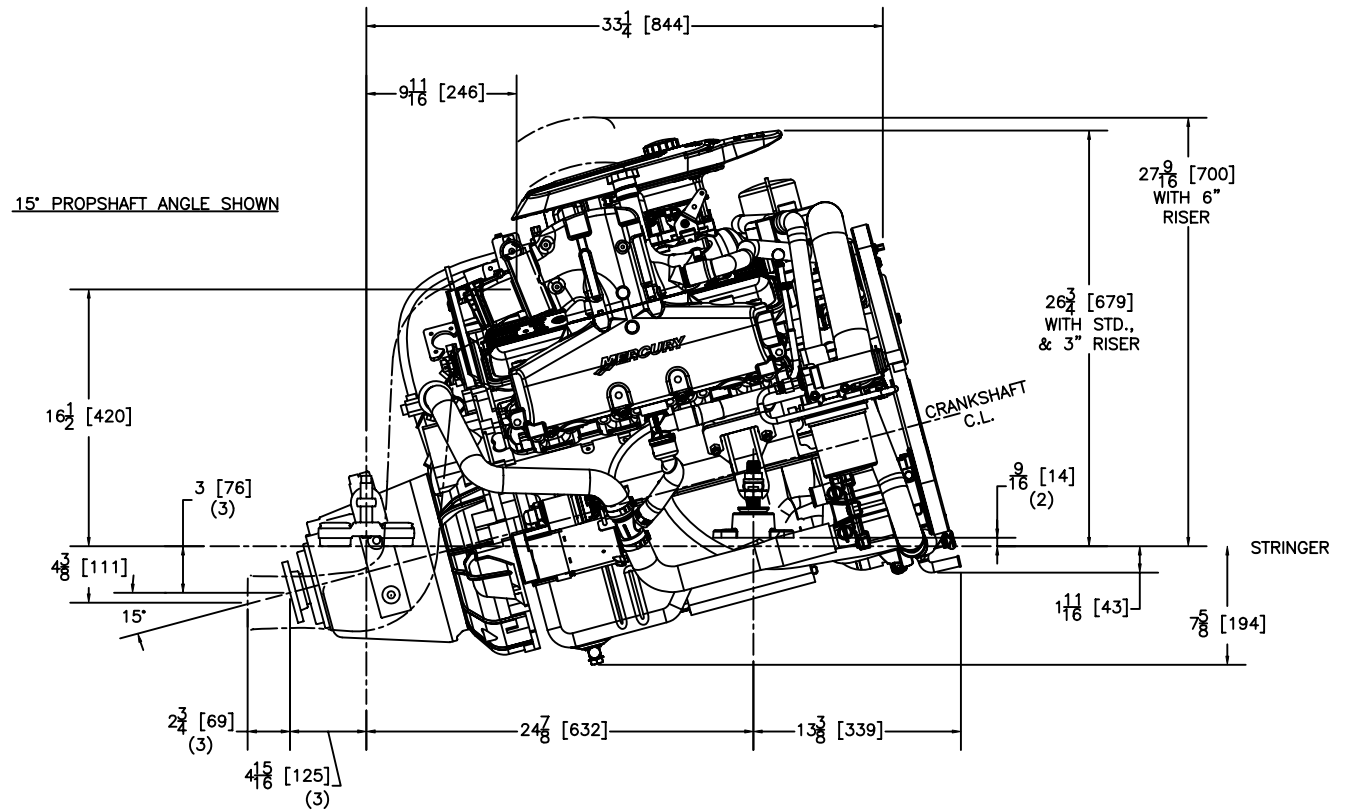

OPTIONAL INTERMEDIATE EXHAUST ELBOW. MERCURUISER P/N 8071537
4 IN.[102] TO 3 IN.[76] DIA.

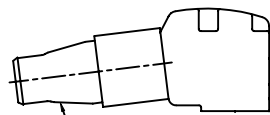

OPTIONAL REDUCER KIT. MERCURUISER P/N 44349A1
4 IN. [102] TO 3 IN. [76] DIA. 7-5/16 [186] LONG

864750 SHEET 4 OF 4
MIE 350 MAG MPI, TOW SPORTS WITH VELVET DRIVE
71C IN-LINE TRANSMISSION

NOTES:

- (1) DIMENSIONS REQUIRE A MINIMUM 1/2 in. (13mm) CLEARANCE FOR MOTOR MOUNT DEFLECTION.
- (2) BASE OF MOUNT TO BE PARALLEL TO STRINGER. MOUNTS SHOWN AT CENTER OF ADJUSTMENT.
- (3) DIMENSIONS APPLY TO POINT OF INTERSECTION OF OUTPUT SHAFT CENTERLINE AND OUTPUT FLANGE FACE.