

ITEM NUMBER
90-864854

REVISIONS			
ZONE	REV	DESCRIPTION	APP'D
01	REVISED		

- NOTES:
1. DIMENSIONS REQUIRE A MINIMUM 13mm [1/2] CLEARANCE FOR MOTOR MOUNT DEFLECTION.
 2. FRONT MOUNTS ADJUST 8mm [5/16] UP OR DOWN.
 3. REAR MOUNTS ADJUST 10mm [3/8] UP OR DOWN.
 4. DIMENSIONS APPLY TO POINT OF INTERSECTION OF OUTPUT SHAFT CENTERLINE AND OUTPUT FLANGE FACE.
 5. SECURE SEAWATER HOSE INLET AWAY FROM ALTERNATOR BELT.
 6. SHOWN WITH ZF63IV TRANSMISSION.
 7. NUMBERS INSIDE BRACKETS ARE IN INCHES.

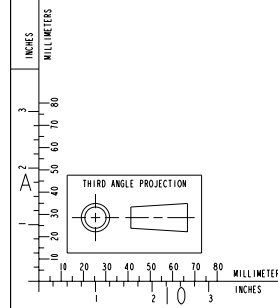
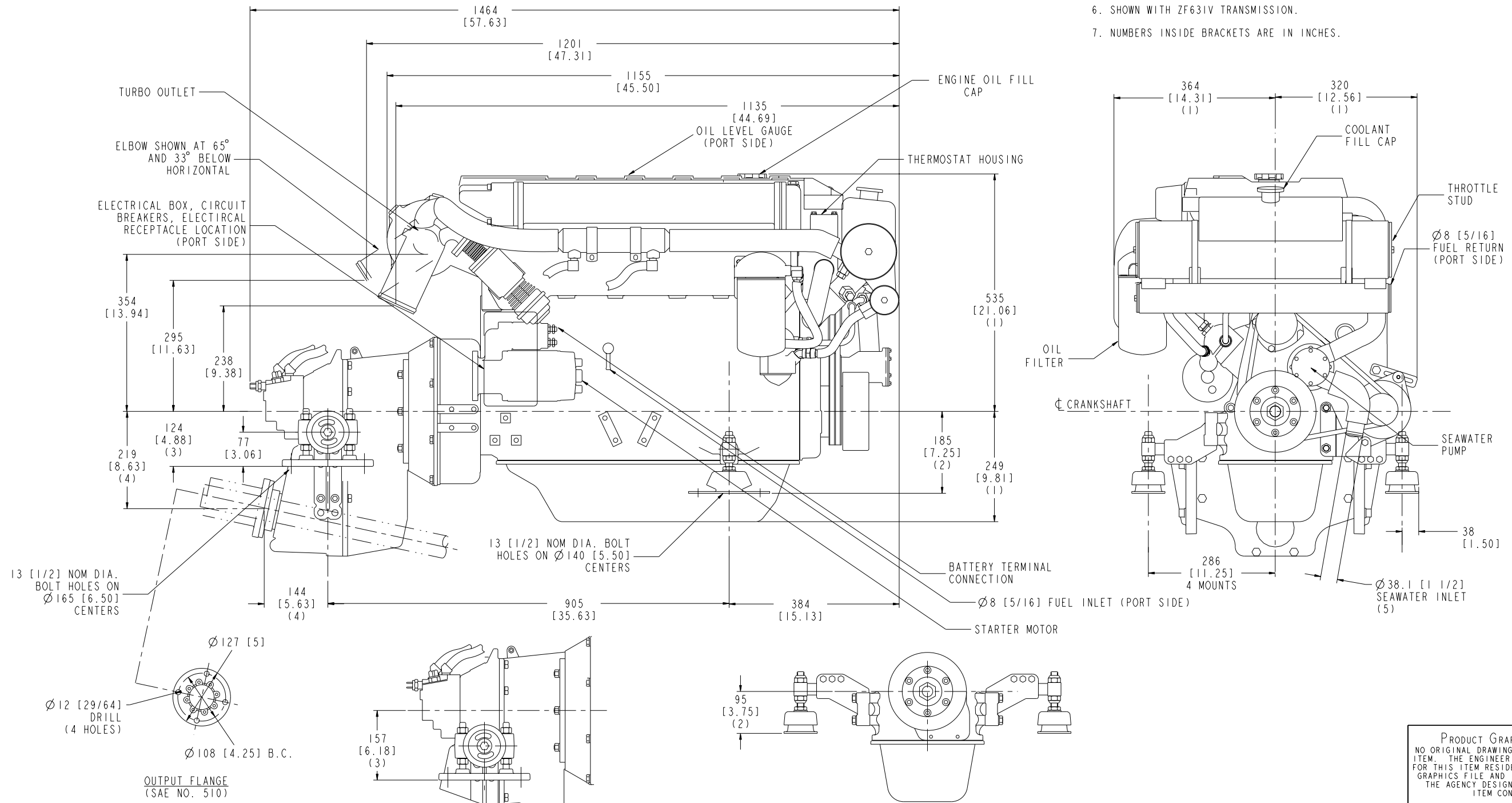

DO NOT SCALE THIS DRAWING
THIS DRAWING/DATA FILE (AND THE INFORMATION SHOWN THEREON) IS CONFIDENTIAL AND PROPRIETARY AND SHALL NOT BE USED, DISCLOSED TO OTHERS, OR REPRODUCED BY ANY MEANS FOR ANY PURPOSE IN HARD COPY FORM OR IN MACHINE READABLE FILES, WITHOUT WRITTEN CONSENT OF CUMMINS INC., MARKETING CAD SERVICES DEPARTMENT.

PRODUCT GRAPHICS FILE
NO ORIGINAL DRAWING EXISTS FOR THIS ITEM. THE ENGINEERING GRAPHICS DATA FOR THIS ITEM RESIDES IN THE PRODUCT GRAPHICS FILE AND IS CONTROLLED BY THE AGENCY DESIGNATED AS HAVING ITEM CONTROL.

LAST SECTION LETTER USED: --	REF. DRAWING STANDARDS: ANSI Y14.5M ISO 81101	CUMMINS INC.	
UNLESS OTHERWISE SPECIFIED DIMENSIONS ARE IN: MM () ARE IN: IN	ITEM NAME: 4.2 EI (250,270,320) w/ ZF63IV	IDENTIFIER: INSTALLATION DIAGRAM	
DWN: S. SOMIN	APPD: UNCHECKED	SCALE: N/A	ITEM CONTROL: MCS
APPD: --	ITEM NUMBER: 90-864854	SHEET 1 OF 1	