

UNIT OF MEASURE in. (mm)	SCALE APROX. 1" = 1' 25.4mm = 304mm
-----------------------------	---

NOTES:  
 (1) DIMENSIONS REQUIRE A MINIMUM 1/2 in. (13mm) CLEARANCE FOR MOTOR MOUNT DEFLECTION.

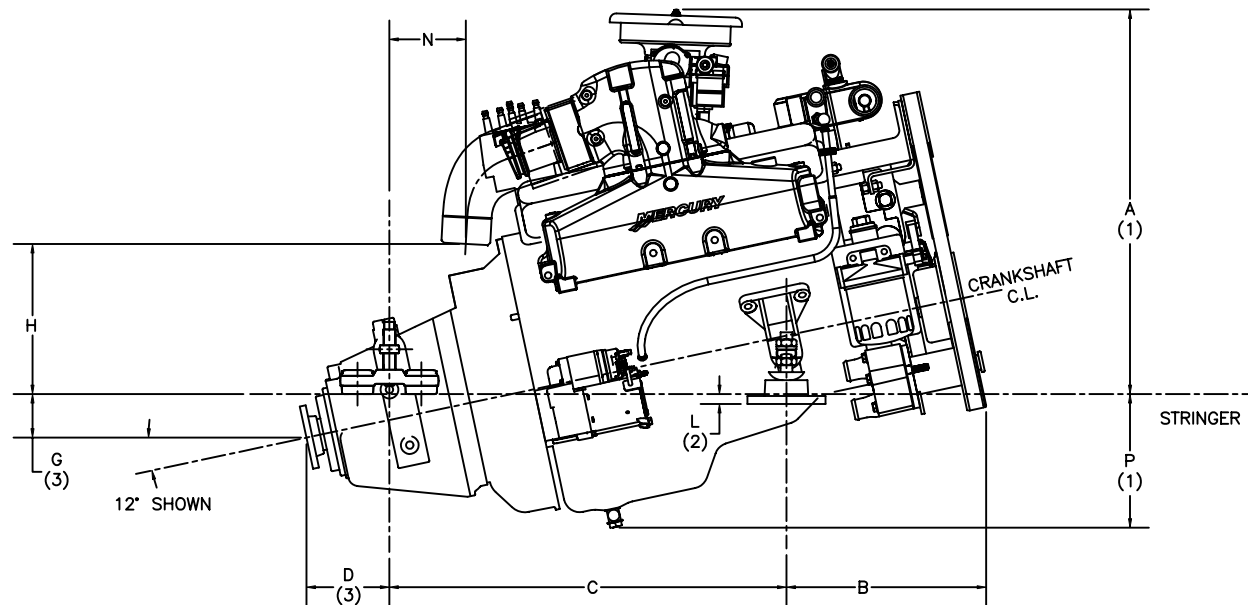

DIMENSIONS	PROPSHAFT ANGLE		
	10°	12°	15°
A	597	613	637
B	315	318	322
C	632	633	633
D	133	132	125
G	65	69	76
H	235	239	246
L	38	116	(- )17
N	128	122	113
P	225	213	194

METRIC  
MM.

DIMENSIONS	PROPSHAFT ANGLE		
	10°	12°	15°
A	23-1/2	24-1/8	25-1/16
B	12-7/16	12-9/16	12-11/16
C	24-7/8	24-15/16	24-7/8
D	5-1/4	5-3/16	4-15/16
G	2-9/16	2-3/4	3
H	9-1/4	9-7/16	9-11/16
L	1-1/2	5/8	(- )11/16
N	5	4-13/16	4-7/16
P	8-7/8	8-3/8	7-5/8

ENGLISH  
IN.

- 864748 SHEET 2 OF 2
- MIE 5.7L SKI WITH VELVET DRIVE 71C IN-LINE TRANSMISSION.
- NOTES:
- (1) DIMENSIONS REQUIRE A MINIMUM 1/2 in. (13mm) CLEARANCE FOR MOTOR MOUNT DEFLECTION.
  - (2) BASE OF MOUNT TO BE PARALLEL TO STRINGER. MOUNTS SHOWN AT CENTER OF ADJUSTMENT.
  - (3) DIMENSIONS APPLY TO POINT OF INTERSECTION OF OUTPUT SHAFT CENTERLINE AND OUTPUT FLANGE FACE.