

FUEL PUMP INLET
3/8 - 18 NPSF

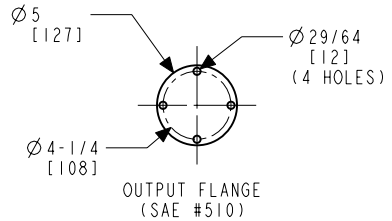
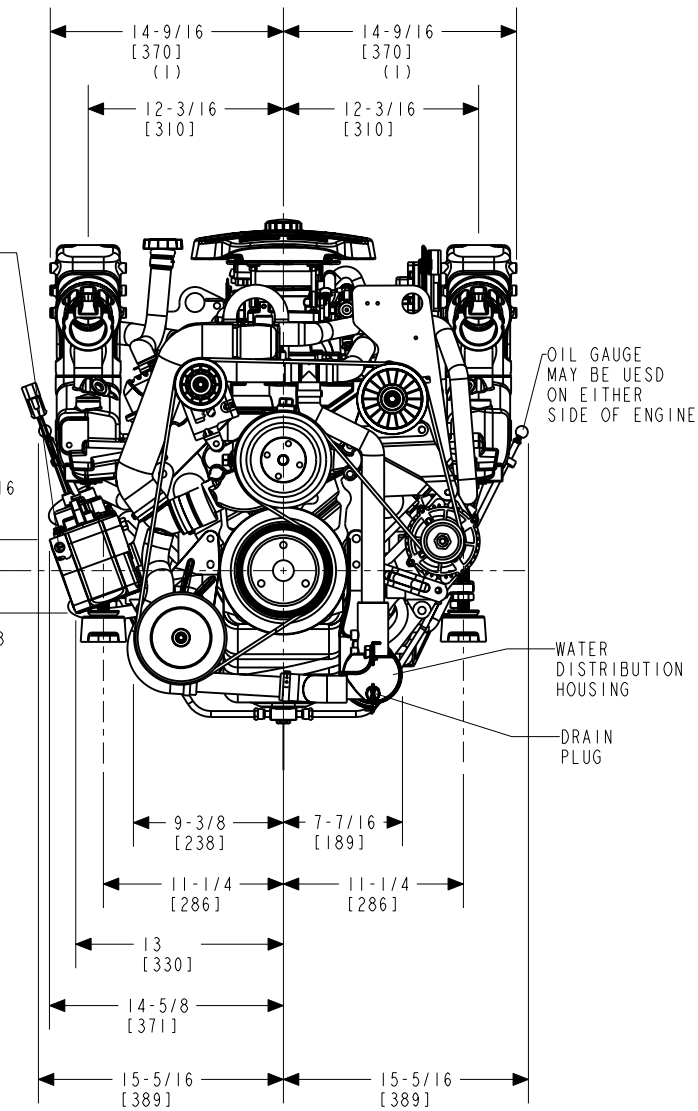

<p>DRW57-013 SHEET 1 OF 4 350 MAG MPI / MX 6.2L MPI WITH VELVET DRIVE 5000V V-DRIVE TRANSMISSION</p>	<p>UNIT OF MEASURE in. (mm)</p>	<p>SCALE 1" = 1' 25.4 mm = 305 mm</p>
<p>NOTES: (1) DIMENSIONS REQUIRE A MINIMUM OF 1/2 in. (13 mm) CLEARANCE FOR MOTOR MOUNT DEFLECTION. (2) SELECT THE APPROPRIATE EXHAUST RISE-HEIGHT TO MAINTAIN A MINIMUM OF 13 in. (330 mm) BETWEEN THE TOP OF THE EXHAUST ELBOW AND THE WATERLINE OF THE BOAT AT MAXIMUM RATED LOAD. (3) DIMENSIONS APPLY TO POINT OF INTERSECTION OF OUTPUT SHAFT CENTERLINE AND OUTPUT FLANGE FACE. (4) DIMENSIONS TO SEA WATER PUMP INLET. (5) BASE OF MOUNT TO BE PARALLEL TO STRINGER. MOUNTS SHOWN AT CENTER OF ADJUSTMENT.</p>		

DRW57-013 SHEET 2 OF 4
350 MAG MPI / MX 6.2L MPI
WITH VELVET DRIVE 5000V V-DRIVE TRANSMISSION

UNIT OF MEASURE
in. (mm)

SCALE
1" = 1'
25.4 mm = 305 mm

NOTES:

- (1) DIMENSIONS REQUIRE A MINIMUM OF 1/2 in. (13 mm) CLEARANCE FOR MOTOR MOUNT DEFLECTION.
- (2) SELECT THE APPROPRIATE EXHAUST RISE-HEIGHT TO MAINTAIN A MINIMUM OF 13 in. (330 mm) BETWEEN THE TOP OF THE EXHAUST ELBOW AND THE WATERLINE OF THE BOAT AT MAXIMUM RATED LOAD.
- (3) DIMENSIONS APPLY TO POINT OF INTERSECTION OF OUTPUT SHAFT CENTERLINE AND OUTPUT FLANGE FACE.
- (4) DIMENSIONS TO SEA WATER PUMP INLET.
- (5) BASE OF MOUNT TO BE PARALLEL TO STRINGER. MOUNTS SHOWN AT CENTER OF ADJUSTMENT.

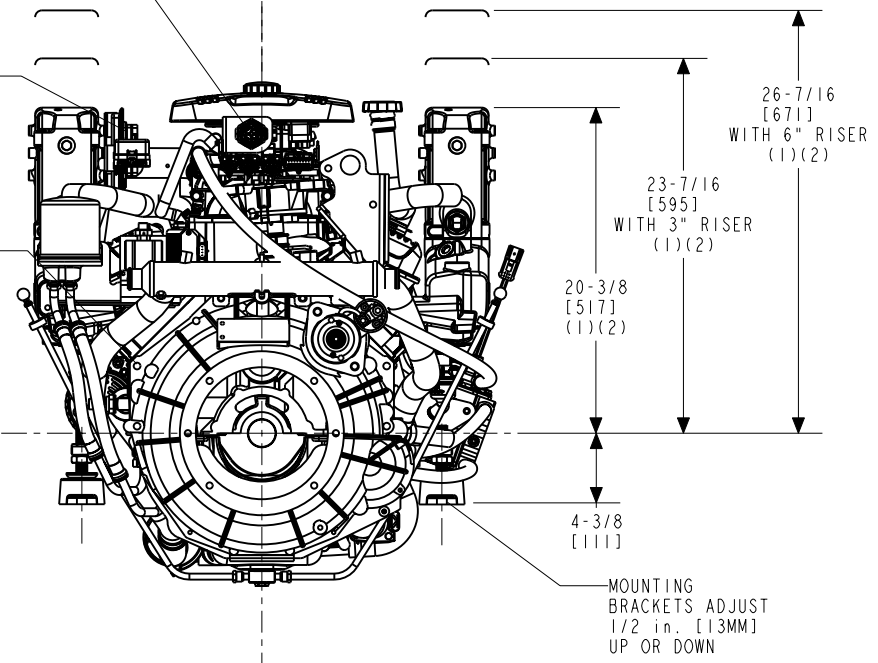
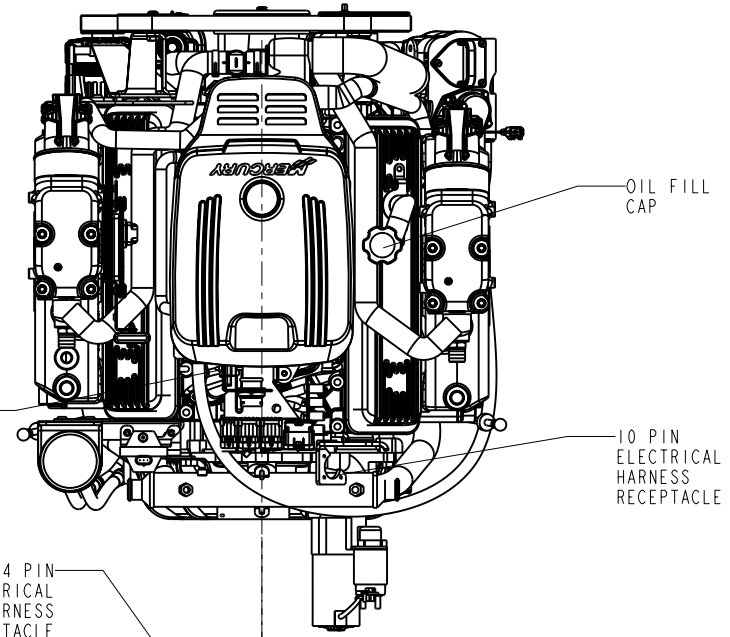
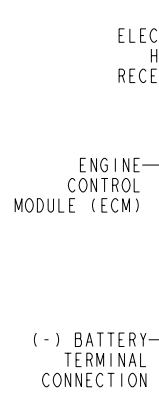
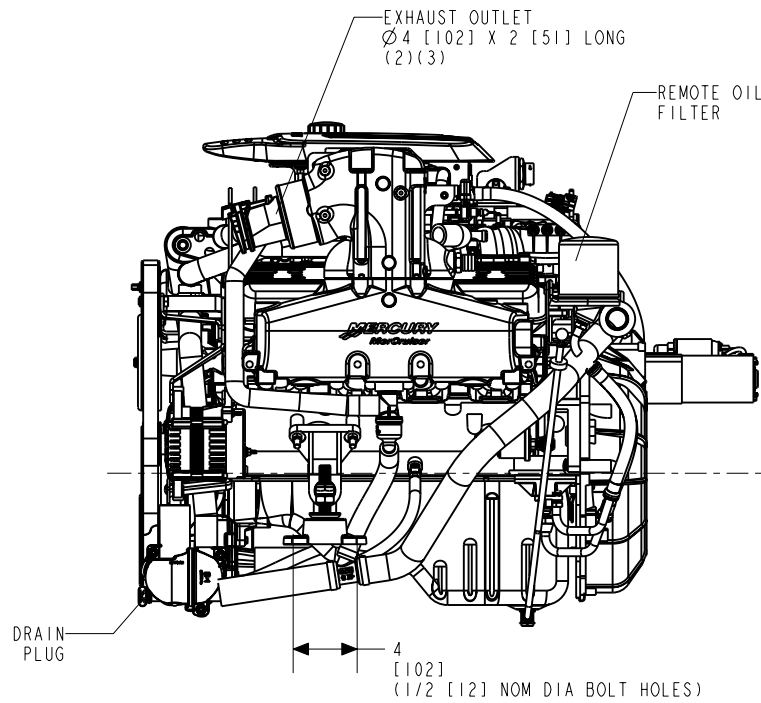

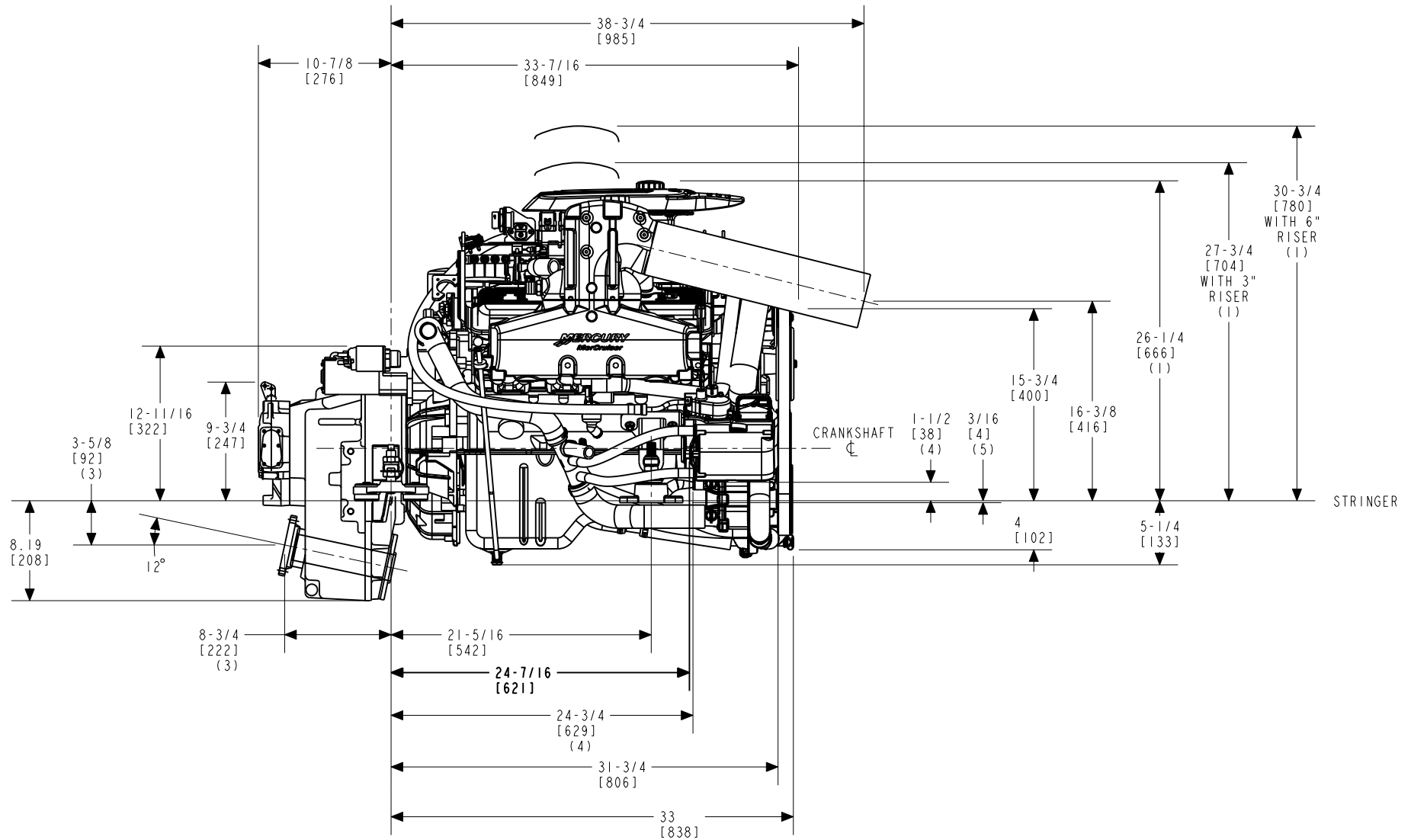

12° PROPSHAFT ANGLE SHOWN

<p>DRW57-013 SHEET 3 OF 4 350 MAG MPI / MX 6.2L MPI WITH VELVET DRIVE 5000V V-DRIVE TRANSMISSION</p>	<p>UNIT OF MEASURE in. (mm)</p>	<p>SCALE 1" = 1' 25.4 mm = 305 mm</p>
<p>NOTES: (1) DIMENSIONS REQUIRE A MINIMUM OF 1/2 in. (13 mm) CLEARANCE FOR MOTOR MOUNT DEFLECTION. (2) SEE THE INSTALLATION MANUAL FOR EXHAUST SPECIFICATIONS. (3) DIMENSIONS APPLY TO POINT OF INTERSECTION OF OUTPUT SHAFT CENTERLINE AND OUTPUT FLANGE FACE. (4) DIMENSIONS TO SEA WATER PUMP INLET. (5) BASE OF MOUNT TO BE PARALLEL TO STRINGER. MOUNTS SHOWN AT CENTER OF ADJUSTMENT.</p>		

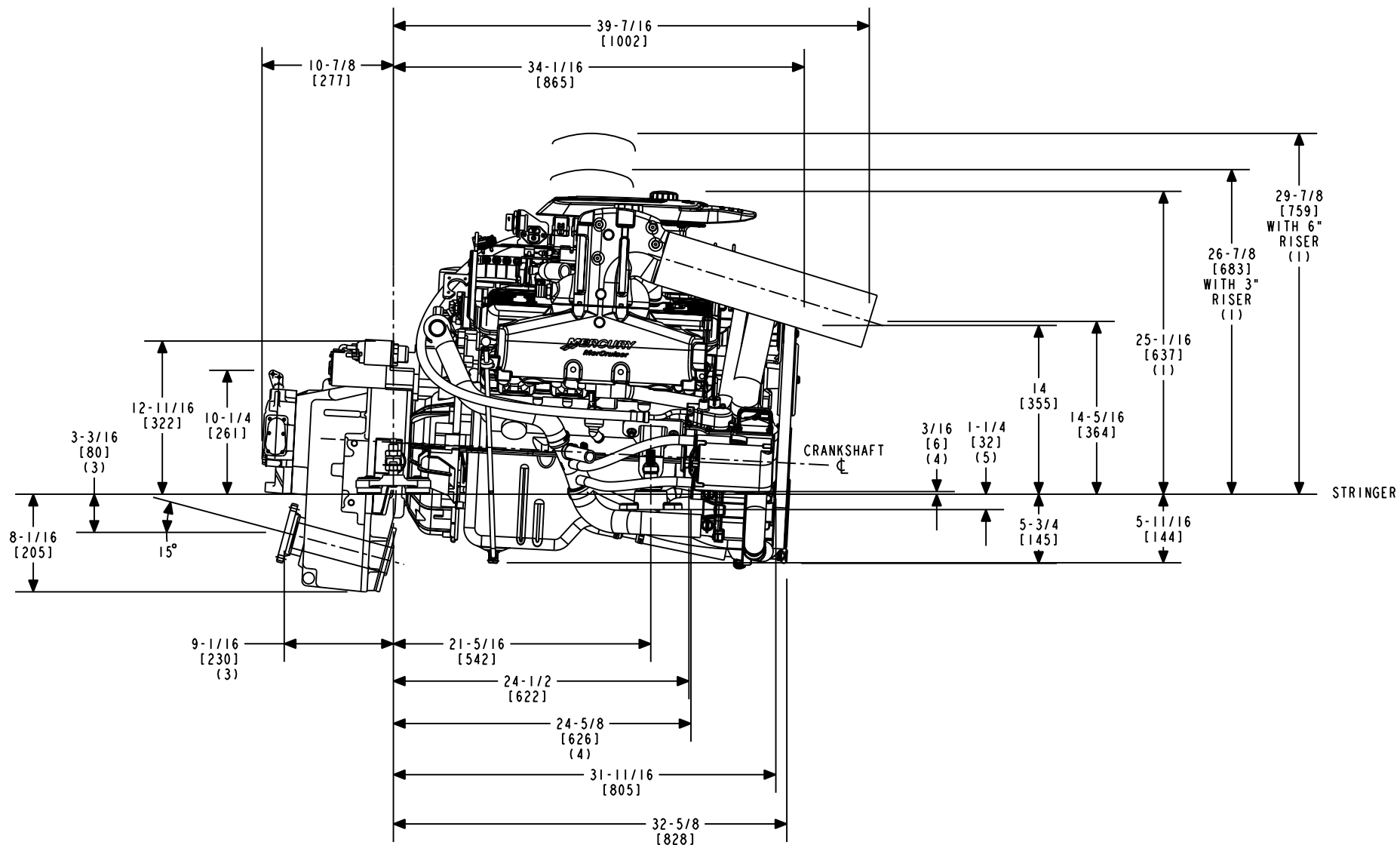

15° PROPSHAFT ANGLE SHOWN

DRW57-013 SHEET 4 OF 4
 350 MAG MPI / MX 6.2L MPI
 WITH VELVET DRIVE 5000V V-DRIVE TRANSMISSION

UNIT OF MEASURE
 in. (mm)

SCALE
 1" = 1'
 25.4 mm = 305 mm

- NOTES:
- (1) DIMENSIONS REQUIRE A MINIMUM OF 1/2 in. (13 mm) CLEARANCE FOR MOTOR MOUNT DEFLECTION.
 - (2) SEE THE INSTALLATION MANUAL FOR EXHAUST SPECIFICATIONS.
 - (3) DIMENSIONS APPLY TO POINT OF INTERSECTION OF OUTPUT SHAFT CENTERLINE AND OUTPUT FLANGE FACE.
 - (4) DIMENSIONS TO SEA WATER PUMP INLET.
 - (5) BASE OF MOUNT TO BE PARALLEL TO STRINGER. MOUNTS SHOWN AT CENTER OF ADJUSTMENT.