

OUTPUT FLANGE
(SAE NO. 510)

UNIT OF MEASURE in. [mm]	SCALE 1" = 1' 25.4mm = 304mm
-----------------------------	------------------------------------

864780 SHEET 1 OF 4
350 MAG MPI HORIZON/MX 6.2L MPI HORIZON WITH ZF/HURTH 630A DOWN ANGLE TRANSMISSION

- NOTES:
- (1) DIMENSIONS REQUIRE A MINIMUM 1/2 in. (13mm) CLEARANCE FOR MOTOR MOUNT DEFLECTION.
 - (2) DIMENSIONS APPLY TO POINT OF INTERSECTION OF OUTPUT SHAFT CENTERLINE AND OUTPUT FLANGE FACE.
 - (3) DIMENSIONS TO SEA WATER PUMP INLET.

350 MAG MPI HORIZON/MX 6.2L MPI HORIZON WITH ZF/HURTH 630A DOWN ANGLE TRANSMISSION

NOTES:

(1) DIMENSIONS REQUIRE A MINIMUM 1/2 in. (13mm) CLEARANCE FOR MOTOR MOUNT DEFLECTION.

UNIT OF MEASURE in. [mm]	SCALE 1" = 1' 25.4mm = 304mm
-----------------------------	------------------------------------

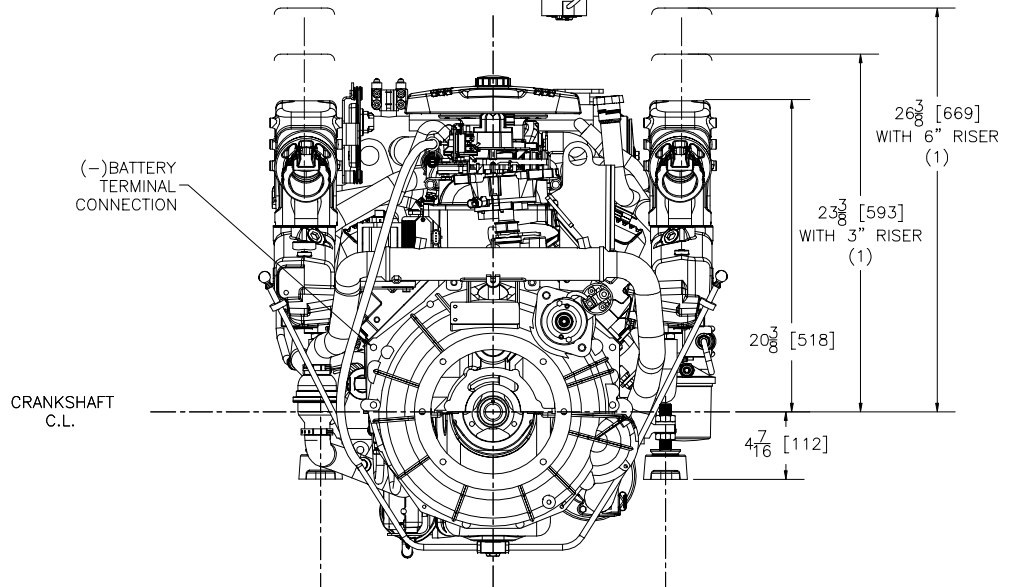
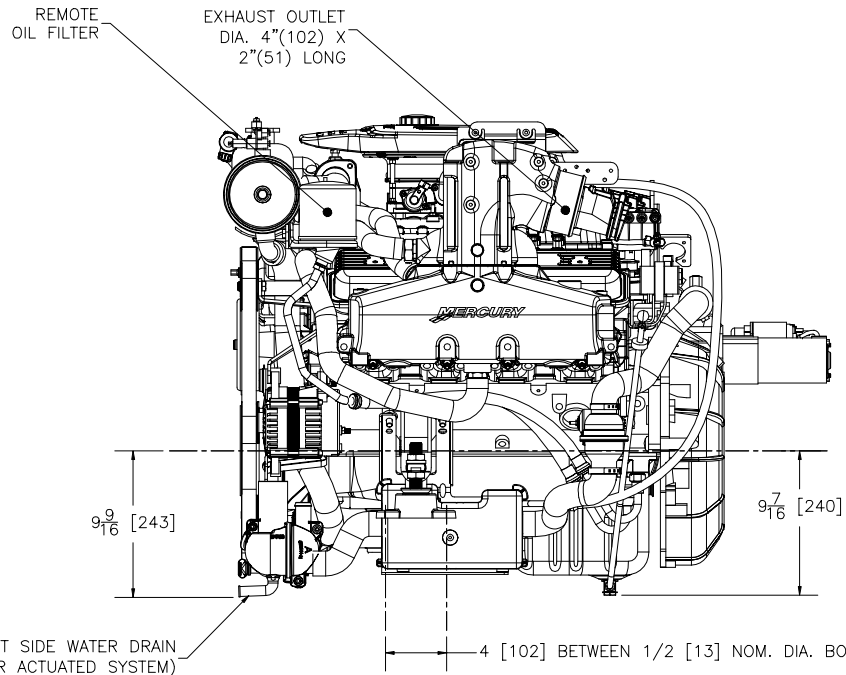
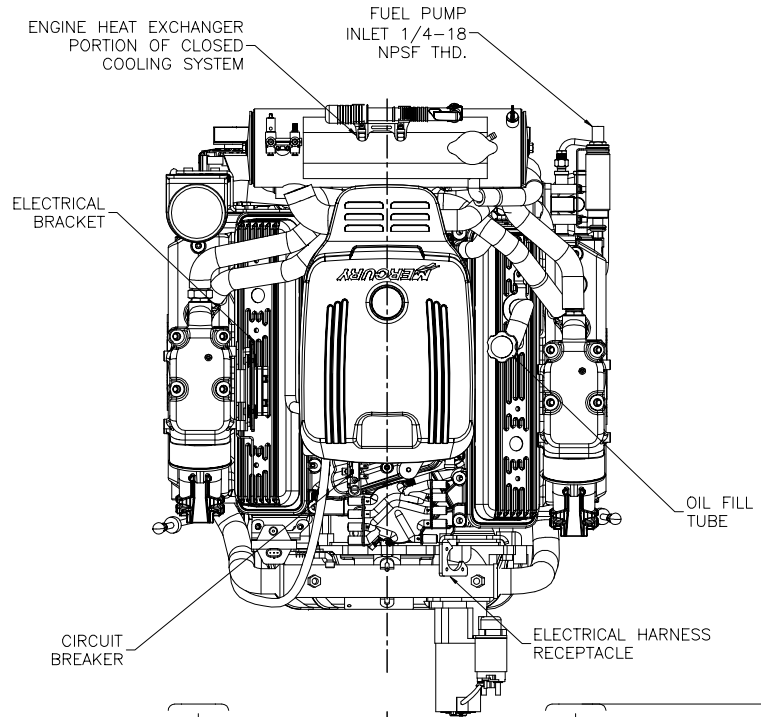

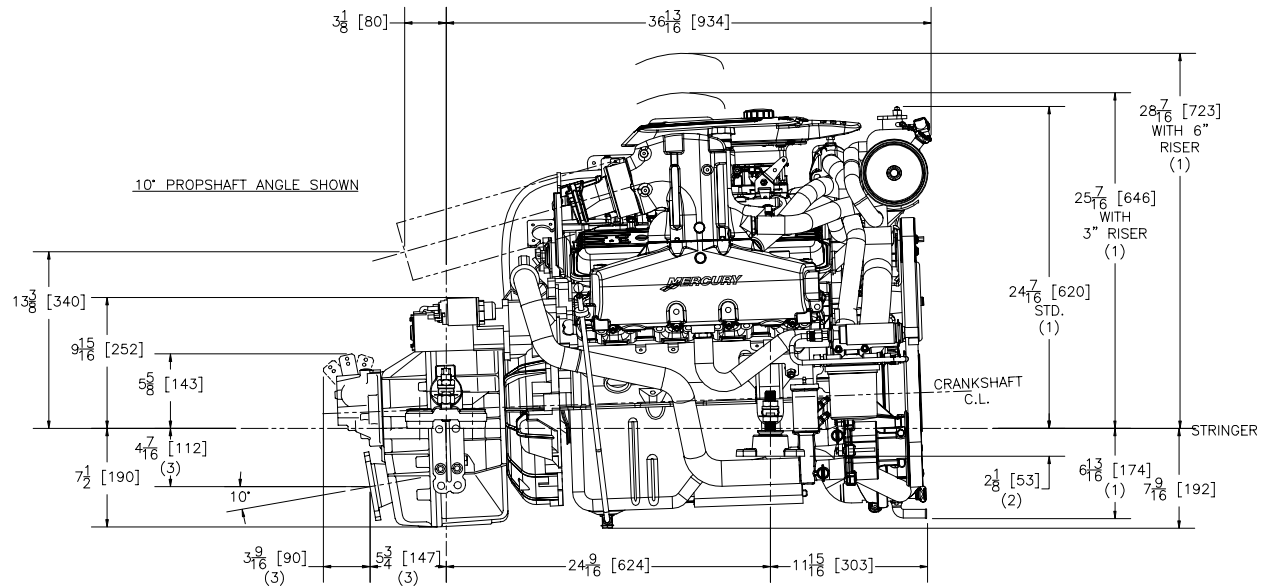

864780 SHEET 3 OF 4
 350 MAG MPI HORIZON/MX 6.2L MPI HORIZON WITH ZF/HURTH 630A DOWN ANGLE TRANSMISSION

NOTES:

- (1) DIMENSIONS REQUIRE A MINIMUM 1/2 in. (13mm) CLEARANCE FOR MOTOR MOUNT DEFLECTION.
- (2) BASE OF MOUNT TO BE PARALLEL TO STRINGER. MOUNTS SHOWN AT CENTER OF ADJUSTMENT.
- (3) DIMENSIONS APPLY TO POINT OF INTERSECTION OF OUTPUT SHAFT CENTERLINE AND OUTPUT FLANGE FACE.

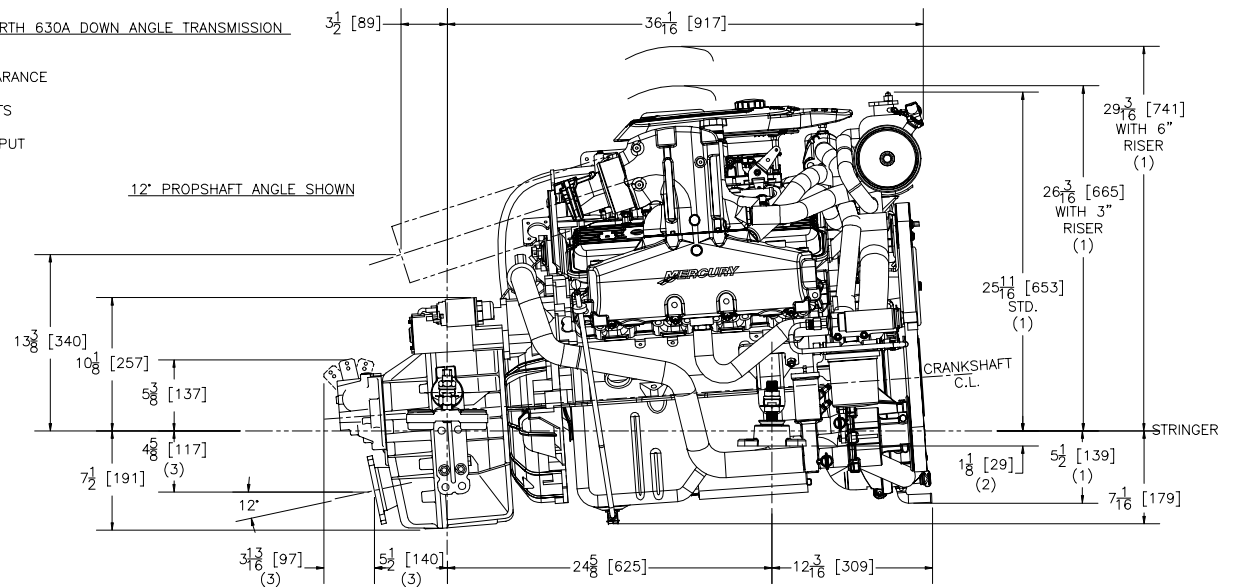

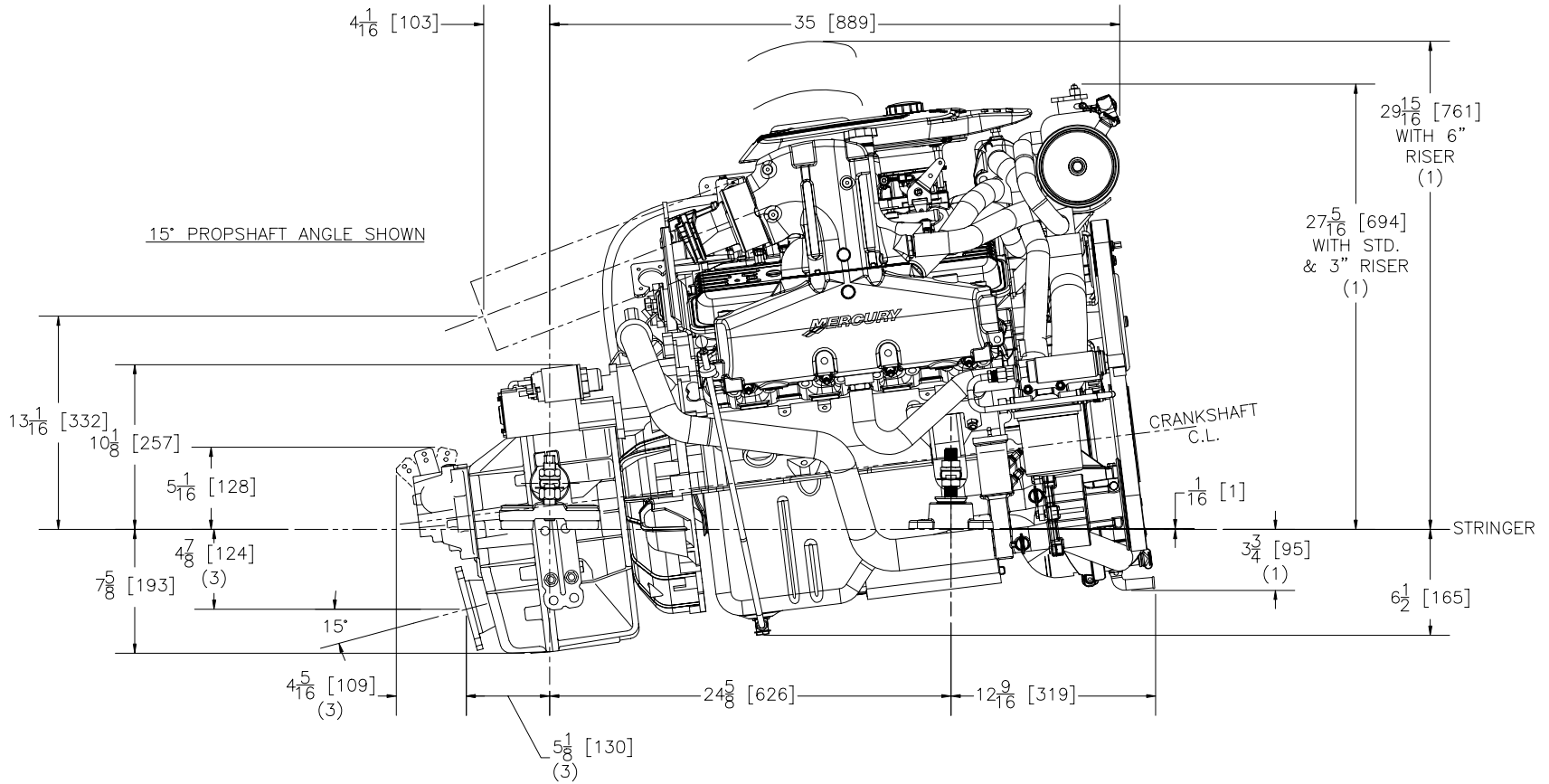

864780 SHEET 4 OF 4
 350 MAG MPI HORIZON/MX 6.2L MPI HORIZON WITH ZF/HURTH 630A DOWN ANGLE TRANSMISSION

NOTES:

- (1) DIMENSIONS REQUIRE A MINIMUM 1/2 in. (13mm) CLEARANCE FOR MOTOR MOUNT DEFLECTION.
- (2) BASE OF MOUNT TO BE PARALLEL TO STRINGER. MOUNTS SHOWN AT CENTER OF ADJUSTMENT.
- (3) DIMENSIONS APPLY TO POINT OF INTERSECTION OF OUTPUT SHAFT CENTERLINE AND OUTPUT FLANGE FACE.