

SCC-1 SMARTCRAFT CONNECT GATEWAY

8M0222354 823 eng

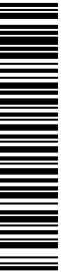

IMPORTANT: This document guides our dealers, boatbuilders, and company service personnel in the proper installation or service of our products. If you have not been trained in the recommended servicing or installation procedures for these or similar Mercury Marine products, have the work performed by an authorized Mercury Marine dealer technician. Improper installation or servicing of the Mercury product could result in damage to the product or personal injury to those installing or operating the product. Always refer to the appropriate Mercury Marine service manual for component removal and installation instructions.

Components in Kit

NOTE: The termination band on the 10-pin connector cable only applies to under cowl mounted modules.

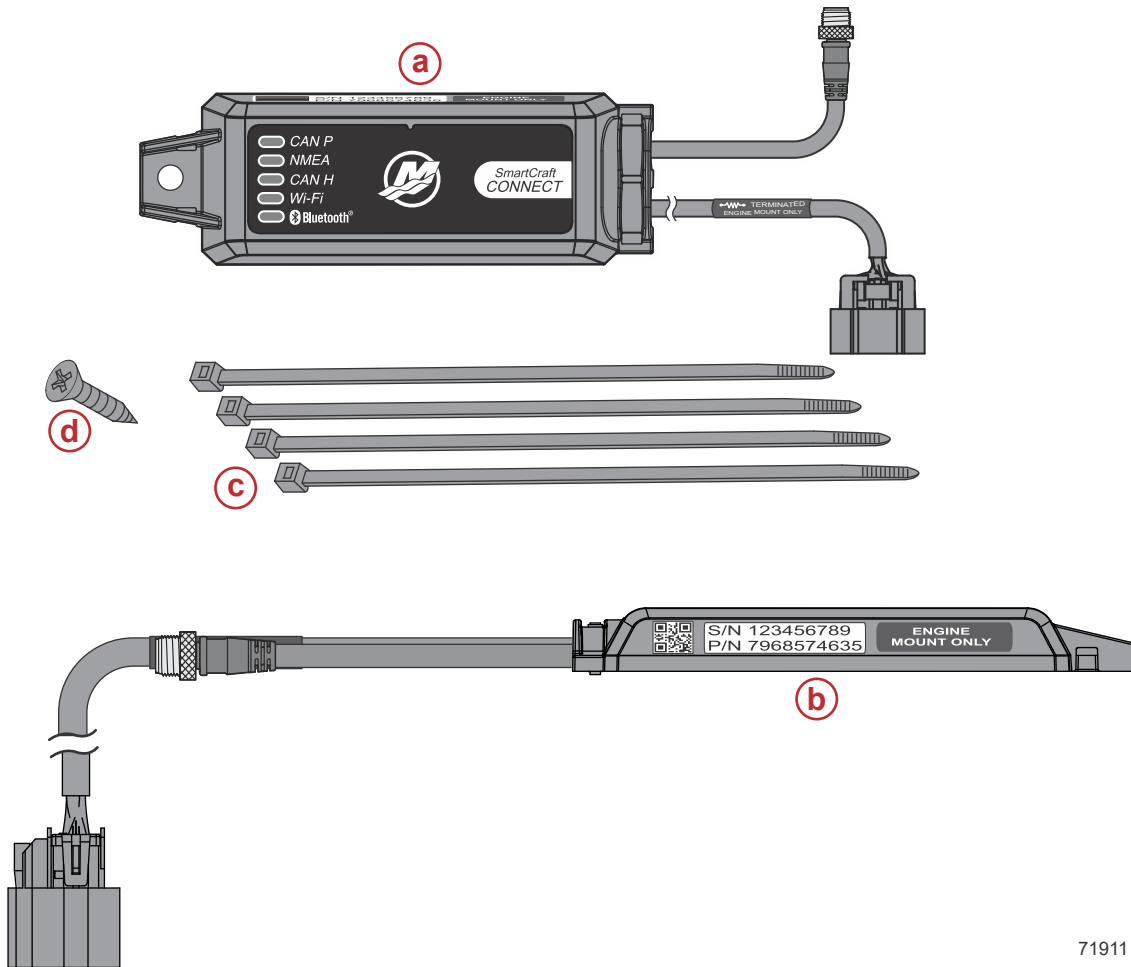

71911

- a** - SmartCraft CONNECT module
- b** - SmartCraft CONNECT module - side view
- c** - Cable ties - 4
- d** - #10 x .88" stainless steel wood screw

Features

The CAN P, CAN H, and NMEA lights will turn on when data is being transmitted through the Gateway.

NOTE: This manual covers the installation of CAN P only - engine mounted module (single). The helm mount module will default out of the box to CAN P, and must be dealer or OEM configured to use CAN H. CAN H is applicable to Dual, Triple, and Quad DTS engine applications.

SmartCraft CONNECT Module—Single- through Quad-Engine

NOTE: The Connect module does not provide power for any device on the NMEA 2000 network. The NMEA 2000 network will require its own power source. The NMEA 2000 network power input must have appropriate circuit protection for the devices on the NMEA 2000 network.

NOTE: The termination band on the 10-pin connector cable only applies to under cowl mounted modules.

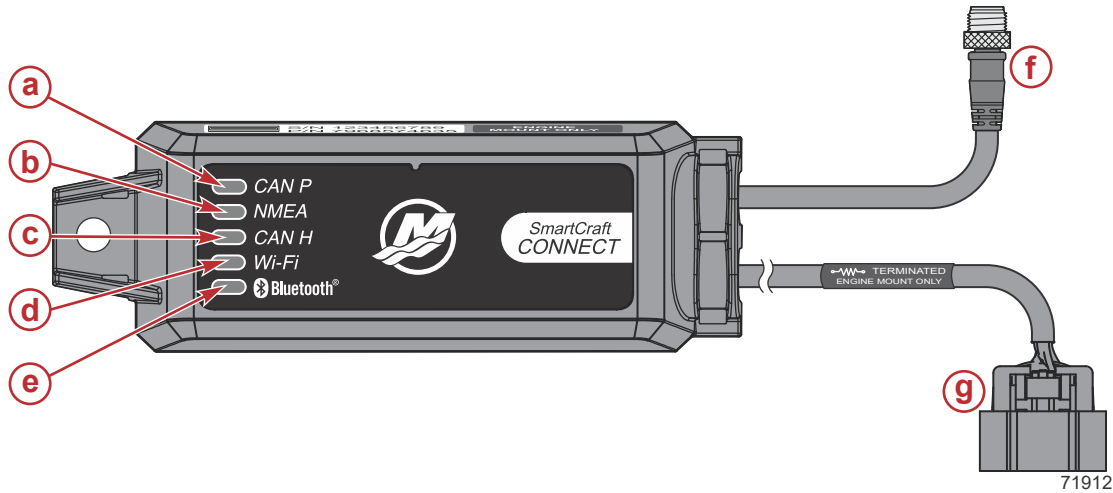

- a - CAN P connection light
- b - NMEA connection light
- c - CAN H connection light
- d - Wi-Fi connection light
- e - Bluetooth® connection light
- f - NMEA 2000® connector
- g - 10-pin connector

Module Harness Connections

1. Connect the SmartCraft CONNECT module in one of the two following ways:
 - a. Connect the CAN 10-pin harness connector to the SmartCraft junction box. Refer to the following diagram.
 - b. Connect the CAN 10-pin harness connector to the helm harness SmartCraft 10-pin connection using a male-male adapter harness.
2. Connect the module NMEA 2000 harness connector to the NMEA 2000 network.

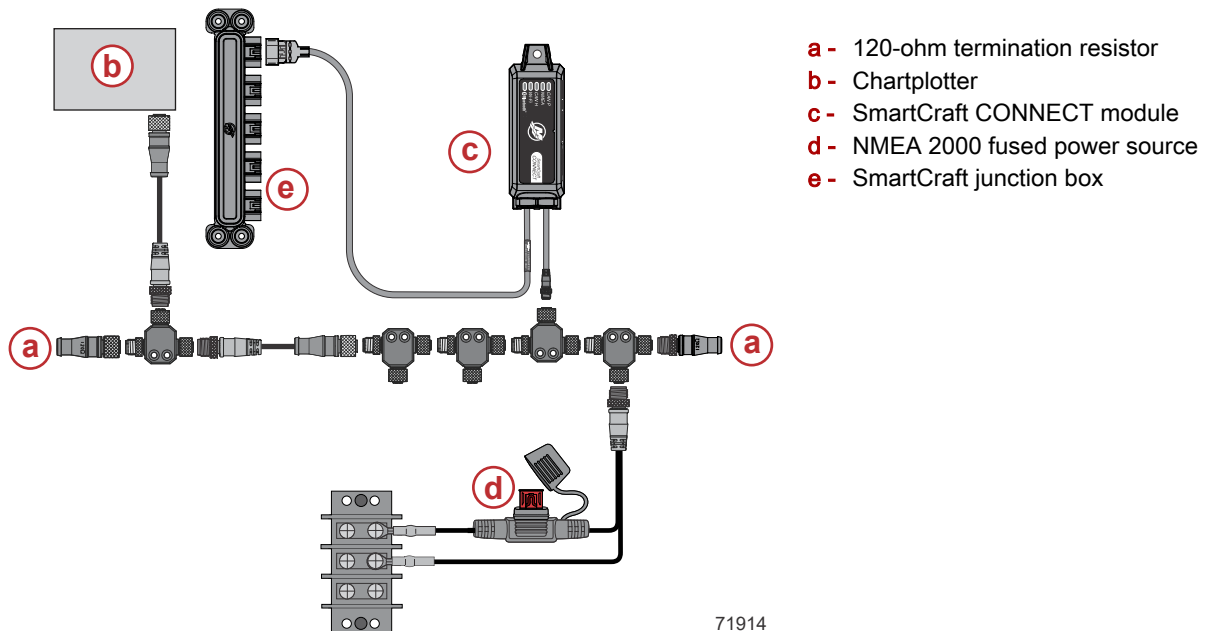

Troubleshooting

LED Lighting

The device contains 5 LEDs for indicating the status of CAN P, NMEA, CAN H, Wi-Fi, and Bluetooth®.

1. **CAN P**

- **Flashing:** The LED will flash continuously once power is applied.
- **Solid:** Once the bus communication is established, the LED will remain on.

2. **NMEA**

- **Flashing:** The LED will flash continuously once power is applied.
- **Solid:** Once the bus communication is established, the LED will remain on.

3. **CAN H**

NOTE: The CAN H LED will not function on engine mount models.

- **Flashing:** The LED will flash continuously once power is applied.
- **Solid:** Once the bus communication is established, the LED will remain on.

4. **Wi-Fi**

- **Off:** No connection.
- **On:** Wi-Fi connection established.

5. **Bluetooth**

- **Flashing:** The Bluetooth LED will flash while in pairing mode, indicating it is not currently connected.
- **Solid:** The Bluetooth LED will remain on continuously while connected.

SmartCraft CONNECT Module NMEA 2000 Information

The software is capable of transmitting (TX) information to, and receiving (RX) information from various parameter group number (PGN) products.

NMEA 2000 Network Power Information		Value
NMEA 2000 Load Equivalency Number (LEN)		1

SmartCraft CONNECT Module Modes	
Transmit (TX)	Receive (RX)
Transmits Mercury data to NMEA 2000 display devices.	Receives data from NMEA 2000 to display on Mercury devices.

Transmitted NMEA 2000 PGNs			
NMEA 2000 PGN	Special Information	Signal	Mode
59392/0xE800	–	ISO Acknowledgment	TX
59904/0xEA00	–	ISO Request	TX
60160/0xEB00	–	ISO Transport Protocol, Data Transfer	TX
60416/0xEC00	–	ISO Transport Protocol, Connection Manager	TX
60928/0xEE00	–	ISO Address Claim	TX
65280/0xFF00	–	Mercury Marine Proprietary	TX
65310/0xFF1E	–	Mercury Marine Proprietary	TX
126208/0xED00	–	NMEA Group Function	TX
126464/0xEE00	–	PGN List	TX
126720/0x1EF00	–	Mercury Marine Proprietary	TX
126992/0xF010	–	System Time	TX
126993/0x1F011	–	Heartbeat	TX
126996/0x1F014	–	Product Information	TX
126998/0x1F016	–	Configuration Information	TX
127245/0x1F10D	–	Rudder	TX
127250/0x1F112	–	Vessel Heading	TX
127251/0x1F113	–	Rate of Turn	TX

Transmitted NMEA 2000 PGNs			
127257/0x1F119	-	Attitude	TX
127258/0x1F11A	-	Magnetic Variation	TX
127488/0x1F200	-	Engine Parameters, Rapid Update	TX
127489/0x1F201	-	Engine Parameters, Dynamic	TX
127493/0x1F205	-	Transmission Parameters, Dynamic	TX
127496/0x1F208	-	Trip Fuel Consumption, Vessel	TX
127498/0x1F20A	-	Engine Parameters, Static	TX
127505/0x1F211	-	Fluid Level	TX
127506/0x1F212	-	DC Detailed Status	TX
128259/0x1F503	-	Speed, Water Reference	TX
128267/0x1F50B	-	Water Depth	TX
129025/0x1F801	-	Position, Rapid Update	TX
129026/0x1F802	-	COG & SOG, Rapid Update	TX
129029/0x1F805	-	GNSS Control Status	TX
129538/0x1FA02	-	GNSS Control Status	TX
129540/0x1FA04	-	GNSS Sats in View	TX
130060/0x1FC06	-	Label	TX
130310/0x1FD06	-	Environmental Parameters	TX
130311/0x1FD07	-	Environmental Parameters	TX
130312/0x1FD08	-	Temperature	TX
130316/0x1FD0C	-	Temperature, Extended Range	TX
130576/0x1FE10	-	Trim Tab Status	TX
130816/0x1FF00	-	Mercury Marine Proprietary	TX
130817/0x1FF01	-	Mercury Marine Proprietary	TX
130821/0x1FF05	-	Mercury Marine Proprietary	TX
130822/0x1FF06	-	Mercury Marine Proprietary	TX
130830/0x1FF0E	-	Vessel Parameters, Low Speed Proprietary	TX

Received NMEA 2000 PGNs			
NMEA 2000 PGN	Special Information	Signal	Mode
59392/0xE800	-	ISO Acknowledgment	RX
59904/0xEA00	-	ISO Request	RX
60160/0xEB00	-	ISO Transport Protocol, Data Transfer	RX
60416/0xEC00	-	ISO Transport Protocol, Connection Manager	RX
60928/0xEE00	-	ISO Address Claim	RX
65240/0xFED8	-	ISO Commanded Address	RX
65311/0xFF1F	-	SeaStar, (Mercury Marine Proprietary)	RX
126208/0xED00	-	NMEA Group Function	RX
126720/0xEF00	-	MFD Capabilities, (Mercury Marine Proprietary)	RX
126992/0x1F010	-	System Time	RX
126996/0x1F014	-	Product Information	RX
126998/0x1F016	-	Configuration Information	RX
127250/0x1F112	-	Vessel Heading	RX
127251/0x1F113	-	Rate of Turn	RX
127257/0x1F119	-	Attitude	RX
127258/0x1F11A	-	Magnetic Variation	RX
128259/0x1F503	-	Speed, Water Reference	RX

Received NMEA 2000 PGNs			
128267/0x1F50B	-	Water Depth	RX
129025/0x1F801	-	Position, Rapid Update	RX
129026/0x1F802	-	COG & SOG, Rapid Update	RX
129029/0x1F805	-	GNSS Control Status	RX
129283/0x1F903	-	Cross Track Error	RX
129284/0x1F904	-	Navigational Data	RX
129538/0x1FA02	-	GNSS Control Status	RX
129540/0x1FA04	-	GNSS Sats in View	RX
130820/0x1FF04	-	Pop-up Button Command, (Mercury Marine Proprietary)	RX

Mercury Engine Data to NMEA 2000 Capable Products			
Signal	Special Information	NMEA 2000 PGN	Mode
Rated RPM	-	127498/0x1F20A	TX
Coolant pressure	-	127489/0x1F201	TX
Speed over water (paddle and pitot)	-	128259/0x1F503	TX
RPM (rapid update)	-	127488/0x1F200	TX
Voltage	-	127489/0x1F201	TX
Coolant temperature	-	127489/0x1F201	TX
Fuel pressure	-	127489/0x1F201	TX
Fuel level (percent, type)	-	127505/0x1F211	TX
Fuel flow	-	127489/0x1F201	TX
Oil pressure	-	127489/0x1F201	TX
Oil temperature	-	127489/0x1F201	TX
Gear temp	-	127493/0x1F205	TX
Gear pressure	-	127493/0x1F205	TX
Boost pressure	-	127488/0x1F200	TX
Trim position	-	127488/0x1F200	TX
Rudder angle	-	127245/0x1F10D	TX
Depth	-	128267/0x1F50B	TX
Depth offset	-	128267/0x1F50B	TX
Seawater temp	-	130310/0x1FD06	TX
Engine hours	-	127489/0x1F201	TX
Alarm data	NMEA 2000 alarm data is limited and will only display "Check Engine" when an alarm is activated. Refer to the Mercury SmartCraft Gauges for descriptive fault text.	127489/0x1F201	TX
Tabs	-	130576/0x1FE10	TX
Course over ground	-	129026/0x9F802	RX/TX
Speed over ground	-	129026/0x9F802	RX/TX
GPS position	-	129025/0x1F801	RX
Gear position	-	127493/0x1F205	TX
Engine load (diesel)	-	127489/0x1F201	TX

SmartCraft CONNECT Module to NMEA 2000 Capable Products			
Signal	Special Information	NMEA 2000 PGN	Mode
Heading	-	127250/0x1F112	RX/TX
Waypoint ID	-	129284/0x1F904	RX
Waypoint position (latitude/longitude)	-	129284/0x1F904	RX
Cross track error	-	129283/0x1F903	RX
Manufacturer ID	Address claim (0 x 90 = Mercury)	060928/0xEE00	TX

SmartCraft CONNECT Module to NMEA 2000 Capable Products			
Signal	Special Information	NMEA 2000 PGN	Mode
Product info	-	126996/0x1F014	TX

Regulatory Information

FCC and ISED

This device complies with Part 15 of the FCC Rules and Innovation, Science and Economic Development Canada License-exempt RSS standard(s). Operation is subject to the following two conditions: 1) This device may not cause harmful interference, and 2) This device must accept any interference received, including interference that may cause undesired operation.

Cet appareil est conforme aux normes RSS exemptes de licence d'Innovation, Science et Développement économique Canada. Son fonctionnement est soumis aux deux conditions suivantes: 1) cet appareil ne doit pas provoquer d'interférences, et 2) cet appareil doit accepter toute interférence, y compris les interférences susceptibles de provoquer un fonctionnement indésirable de l'appareil.

Warning: Changes or modifications not expressly approved by the party responsible for compliance could void the user's authority to operate the equipment.

This equipment has been tested and found to comply with the limits for a Class B digital device, pursuant to Part 15 of the FCC Rules. These limits are designed to provide reasonable protection against harmful interference in a residential installation. This equipment generates uses and can radiate radio frequency energy and, if not installed and used in accordance with the instructions, may cause harmful interference to radio communications. However, there is no guarantee that interference will not occur in a particular installation. If this equipment does cause harmful interference to radio or television reception, which can be determined by turning the equipment off and on, the user is encouraged to try to correct the interference by one of the following measures:

- Reorient or relocate the receiving antenna.
- Increase the separation between the equipment and receiver.
- Connect the equipment into an outlet on a circuit different from that to which the receiver is connected.
- Consult the dealer or an experienced radio/TV technician for help.

RF Exposure Considerations

To comply with FCC and Innovation, Science and Economic Development Canada RF exposure limits for general population / uncontrolled exposure, the antenna must be installed to provide a separation distance of at least 20 cm from all persons and operating in conjunction with any other antenna or transmitter, except in accordance with FCC multi-transmitter product procedures.

Pour se conformer aux limites d'exposition aux RF de la FCC et d'Industrie Canada pour la population générale / exposition non contrôlée, l'antenne(s) utilisée pour ce transmetteur doit être installé pour fournir une distance de séparation d'au moins 20cm de toutes les personnes et fonctionnant conjointement avec une autre antenne ou émetteur, sauf en conformité avec les procédures de produits multi- émetteur FCC.

IFT (México)

La operación de este equipo está sujeta a las siguientes dos condiciones: (1) es posible que este equipo o dispositivo no cause interferencia perjudicial y (2) este equipo o dispositivo debe aceptar cualquier interferencia, incluyendo la que pueda causar su operación no deseada.