

UNIT OF MEASURE in. [mm]	SCALE 1" = 1" 25.4mm = 304mm
-----------------------------	------------------------------------

864751 SHEET 1 OF 2
MIE 350 MAG MPI TOW SPORTS WITH VELVET DRIVE
71C & WALTER V-DRIVE

NOTES:

- (1) DIMENSIONS REQUIRE A MINIMUM 1/2 in. (13mm) CLEARANCE FOR MOTOR MOUNT DEFLECTION.
- (2) DIMENSIONS TO SEA WATER PUMP INLET.

864751 SHEET 2 OF 2
 MIE 350 MAG MPI TOW SPORTS WITH VELVET DRIVE
 71C & WALTER V-DRIVE

NOTES:

- (1) DIMENSIONS REQUIRE A MINIMUM 1/2 in. (13mm) CLEARANCE FOR MOTOR MOUNT DEFLECTION.
- (2) SELECT THE APPROPRIATE EXHAUST RISE-HEIGHT TO MAINTAIN A MINIMUM OF 13 in. (330mm) BETWEEN THE TOP OF THE EXHAUST ELBOW AND THE WATERLINE OF THE BOAT AT MAXIMUM RATED LOAD.
- (3) EXHAUST OUTLETS MUST BE ABOVE WATERLINE OF BOAT AT MAXIMUM RATED LOAD.

UNIT OF MEASURE	SCALE
in. [mm]	1" = 1' 25.4mm = 304mm

EXHAUST OUTLET
 DIA. 4"(102) X
 2"(51) LONG
 (2)(3)

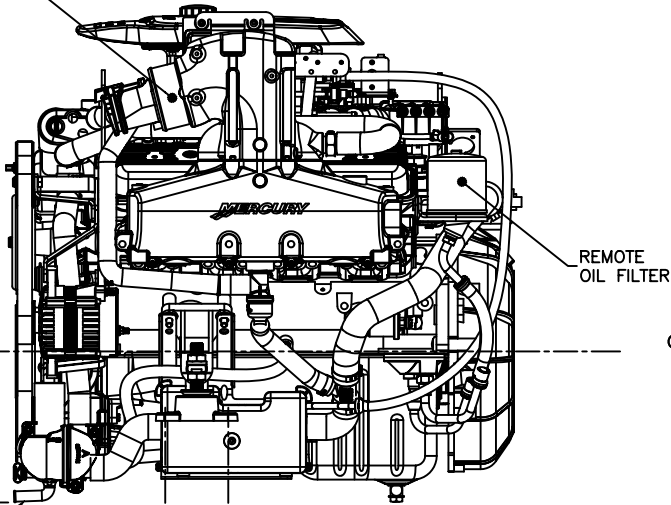

SINGLE POINT
 WATER DRAIN

4 [102] BETWEEN 1/2 [13] NOM. DIA. BOLT HOLES

CRANKSHAFT
 C.L.

(-)BATTERY
 TERMINAL
 CONNECTION

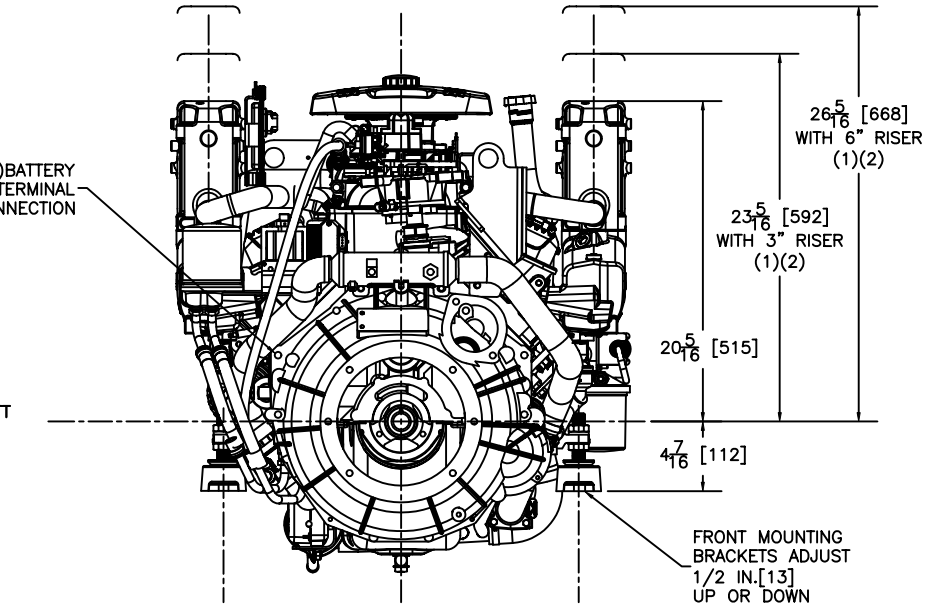

FRONT MOUNTING
 BRACKETS ADJUST
 1/2 IN.[13]
 UP OR DOWN

